

CHAPTER 3

INFORMATION ON

APPLICATION FOR SUPPLY

CHAPTER 3

INFORMATION ON APPLICATION FOR SUPPLY

3.1 Application for Supply to New Building

1. Supply would, as decided by HK Electric, either be provided by establishing a customer's substation at the building or by direct cables from existing low voltage network.
2. Supply arrangement, requirements of substation/cable entry ducts and other facilities required for provision of supply would normally be agreed with the authorised architect/consultant responsible for the development at an early stage of the building construction.
3. For supply with establishment of a new substation, the substation should be constructed and handed over to HK Electric in a complete condition and other facilities (as required) provided. Installation work will take about six weeks to complete after acceptance of all these facilities provided by the developers, payment of service charge (if any) and after receipt of all necessary permits issued by relevant government authority/private land owner. [Please see Clause 3.10 (1 & 2)]
4. For supply from existing low voltage network, the cable entry ducts and other facilities as required should be provided. Installation work will take about four weeks to complete after acceptance of all these facilities, payment of service charge (if any) and after receipt of all necessary permits issued by relevant government authority/private land owner. [Please see Clause 3.10 (1 & 2)]
5. Under normal circumstances, the supply scheme will be prepared and service charge (if any) determined in about two weeks after receipt of formal application for supply. For exceptional cases where special type of equipment or complicated supply arrangements are involved, an additional two weeks may be needed for determination of service charge. [Please see Clause 3.10 (1 & 2)]

3.2 Application for Supply to Village Houses on Hong Kong Island or 3-Storey Houses on Lamma Island

1. Supply would normally be provided by direct cables from existing low voltage network. However, there would be some special cases where supply would be provided by low voltage overhead wires.
2. Formal application for supply should be submitted as early as possible. The applicant will be advised of HK Electric requirements of the cable entry ducts, weatherproof enclosure and/or other facilities in about four weeks upon receipt of the application.
3. Apart from preparation of the supply scheme, approval of excavation permit from District Lands Office will require about another three months. Should there be any private lot involved along the excavation route, written approval from all private lot owners must be received before the applicant is asked to pay the service charge required for provision of supply.
4. The cable entry ducts, weatherproof enclosure and/or other facilities as required should be provided. Installation work will take about four weeks to complete after acceptance of all these facilities, payment of service charge (if any) and receipt of all necessary permits issued by relevant government authority/private land owner. [Please see Clause 3.10 (1 & 2)]

3.3 Application for Supply (New or Additional) at Existing Building

1. It must not be assumed that such supply (even if it is a small supply or application for transfer) at existing building can be obtained at short notice because the existing supply system may have already been loaded to its capacity and need reinforcement.
2. For application of a very large supply, a new substation or extension of the existing substation at the building may be required. This will involve alteration of building plans and will have to be handled by authorised architect/consultant. The whole process of providing supply including negotiation of substation space, approval from relevant Government Authorities, construction/extension of substation, inspection and handing over of substation, commissioning of substation and connection of supply may take six months to a few years.

3. Application of smaller supply may also necessitate the installation of additional service cable or replacement of existing service cable supplying the building. The applicant will be advised of the supply situation, HK Electric requirements of the cable entry ducts and other facilities, and service charge required for provision of supply (if any) in about three weeks upon receipt of the application. The cable installation work will take about four weeks to complete after acceptance of all these facilities, payment of service charge (if any) and after receipt of all necessary permits issued by relevant government authority/private land owner. [Please see Clause 3.10 (1 & 2)]
4. The processing time will be much shorter if the application for supply does not require any reinforcement work by HK Electric.
5. It is always the customer's REC/REW responsibility to ensure that prior consent has been obtained from the building management and/or the owners incorporation of the building regarding connection of customer's new or additional load to the distribution system of the building and that connection of customer's new or additional installation will not cause overload to the distribution system of the building.
6. To help speed up the processing of application for supply, the applicants or their RECs/REWs are requested to complete Form DP1 to provide the information on Supply Number details from which the proposed electrical installation will be supplied.
7. The workflow and telephone contact list for application for additional load is shown in Drg. No. GCS/3/01.

3.4 Application for Temporary Supply to Construction Sites

1. HK Electric provides a one-stop service under **Smart Power for Construction Site** (www.hkelectric.com/SPCS-en) to timely provide electricity for construction sites to help reduce carbon emissions throughout the construction life cycle. By replacing diesel generators with grid-powered electricity supply, carbon emissions, air and noise pollution during construction period will be substantially reduced while saving energy cost. HK Electric also provides recommendations and services for further decarbonising construction including use of renewable energy, electric vehicle, and energy efficiency enhancement measures.

2. Customers are highly recommended contacting HK Electric at 2510 2701 or SPCS@hkelectric.com at the earliest possible stage of construction project (e.g. during plan submission to Buildings Department, building demolition/construction tender preparation stage, or hoarding design stage) to enable timely arrangement of adequate temporary site supply. Customers may also submit an Online Service Request Form (available at www.hkelectric.com/SPCS-en) requesting HK Electric one-stop service for arranging construction site temporary supply. Please refer to Drg. No. GCS/3/02 for the workflow of application for construction site temporary supply.
3. In general, supply will be provided either by establishing a transformer pillar at the site (for a requested load above 800 A three-phase) or by direct cables from existing low voltage network (for a requested load at 800 A three-phase or below) to the boundary of the site.
4. If the requested load cannot be supplied from existing low voltage network, a transformer pillar at the site will be required. The transformer pillar will be supplied and installed by HK Electric. To accommodate the pillar, a space of not less than 4 m x 4 m on levelled and stable ground free from flooding and landslip hazard with 1.6-m all-round clearance should be provided. Access to pillar should be freely available at all times and at least one side of the pillar should be along the periphery of the construction site. A customer's main switchroom adjacent to the transformer pillar should also be provided. The access to customer's main switchroom should be freely available at all times and should be at the periphery of the construction site. The low voltage connection will be by single-core cables.
5. For supply with establishment of a transformer pillar, the pillar foundation should be constructed and handed over to HK Electric in a complete condition and other facilities (as required) provided, and service charge required for provision of supply paid at least eight weeks before supply is required. The detailed requirements on the pillar foundation and access to the pillar are shown in Drg. No. GCS/3/11.
6. If the requested load can be supplied from existing low voltage network, a cable will be laid up to the boundary of the site. A weatherproof enclosure for housing service cutout and meter will be supplied by HK Electric but installed by the applicant. The applicant shall install the distribution facilities inside their own switch cubicle. In general, maximum two cables (each with a maximum supply capacity of 400 A three-phase) could be laid to the boundary of the site (at two different supply locations on customer's request) subject to actual low voltage network and site conditions.

7. For supply from existing low voltage network, the installation of weatherproof enclosure and provision of other facilities (such as cable joint bay/cable trench) will be inspected by HK Electric after payment of the service charge. The detailed arrangement of the weatherproof enclosure is shown in Drg. No. GCS/3/09. Cable installation will take about four weeks to complete after acceptance of all these facilities, and after receipt of all necessary permits issued by relevant government authority/private land owner. [Please see Clause 3.10 (1 & 2)]
8. Under normal circumstances, the scheme for supply from existing low voltage network will be prepared and service charge determined in about two weeks after receipt of formal Application Form for Supply/Transfer and location of weatherproof enclosure is agreed. For supply with establishment of a transformer pillar, the scheme will be prepared and service charge determined in about four weeks after receipt of formal application for supply and location of transformer pillar is agreed. [Please see Clause 3.10(1 & 2)]
9. The workflow of application for construction site temporary supply with the above typical arrangements is shown in Drg. No. GCS/3/02.

3.5 Application for Supply to Squatters

1. Supply to squatter hut would be either by central metering scheme or running overhead wires directly to customer's hut depending on the site conditions.
2. For supply to squatter by central metering scheme, the applicant for supply will be required to install a MCB board at the hut and run main wiring back to the pole with central metering cubicles and then fix a RCD complete with overcurrent protection as main switch at the metering cubicle to control the whole installation as per Drg. No. GCS/3/03.
3. For supply to squatter by direct overhead wires, the applicant for supply will be required to provide and install a weatherproof enclosure for housing HK Electric service cutout and meter.
4. Formal application for supply with a sketch indicating the exact location of hut where supply is required should be submitted as early as possible. Upon receipt of the application, HK Electric site engineer will conduct an inspection to see if there is any available central metering cubicle on site and advise the applicant accordingly.

5. If there is no central metering cubicle available and there is suitable space for erecting a central metering pole or adding new metering cubicle at existing pole, a scheme of providing a cubicle will be prepared in about four weeks after receipt of the application. If it involves erection of pole or cable laying in Government Land, District Lands Office will be approached for the issue of the permit, which will take about three months. After the necessary permit (if any) is received, the applicant will be advised of the supply arrangement, the location of the central metering pole and the service charge required for provision of supply. Installation work will take about four weeks to complete after payment of service charge (if any) and receipt of all necessary permits issued by relevant government authority/private land owner. [Please see Clause 3.10 (1 & 2)]
6. If there is no central metering cubicle available and there is no suitable space for adding a central metering cubicle, a scheme for providing supply by direct overhead wires will be prepared. The applicant will be advised of the supply arrangement, the location of the weatherproof enclosure to be provided and installed and the service charge (if required) for provision of supply. The installed weatherproof enclosure will be inspected by HK Electric after payment of the service charge/deposit. Installation work will take about four weeks to complete after payment of service charge (if any) and deposit and acceptance of the weatherproof enclosure. [Please see Clause 3.10 (1 & 2)]

3.6 Application for Supply to Pontoon/Vessel/Boat

1. Customer shall install a socket outlet of appropriate rating inside a weatherproof enclosure erected on shore for supplying electricity to pontoon/vessel/boat.
2. Supply would normally be provided by HK Electric LV service cable/cutout or central metering scheme.
3. The customer main switch shall be of a RCD of 30-mA operating current. It should be equipped with overcurrent protection and adequate short circuit breaking capacity.
4. The supply arrangement is shown in Drg. No. GCS/3/04.

5. Formal application for supply with a sketch indicating the exact location of the weatherproof enclosure and pontoon/vessel/boat where supply is required should be submitted as early as possible. Upon receipt of the application, HK Electric site engineer will conduct an inspection to see how to provide the supply and advise the applicant accordingly.

3.7 Application for Supply to Hawker Stalls

1. Applicant for supply to a stall should submit to HK Electric with the following documents:
 - a. A copy of his licence issued by Food and Environmental Hygiene Department (FEHD)
 - b. A no-objection letter from FEHD on the installation or connection of any electrical wirings or electrical equipment for his hawking purpose.
 - c. A drawing showing his approved licensed area and location.
2. Supply would normally be provided by direct cables from existing LV network. The applicant is required to install a weatherproof enclosure within his licensed area to house HK Electric equipment with the door and window for meter reading facing footpath or public access.
3. The scheme for supply will be prepared and service charge determined in about three weeks after receipt of formal application for supply and the required documents. Cable installation will take about four weeks to complete after receipt of service charge from the applicant, acceptance of the required weatherproof enclosure and receipt of all necessary excavation permits issued by relevant government authority. [Please see Clause 3.10 (1 & 2)]

3.8 Temporary Supply for Filming/Decoration

1. Unmetered Temporary Supply for Filming

Unmetered temporary supply for say, filming purpose, may be considered if the supply required lasts not more than 3 days. However, customer must comply with the requirements of the Supply Rules and the latest edition of the Code of Practice for the Electricity (Wiring) Regulations and provide a copy of Work Completion Certificate prior to connection of supply. The installation shall be protected by a residual current device complete with overcurrent protection main switch at the connection of supply.

2. Metered Temporary Supply for Decoration/Renovation

Unauthorised extension from communal installation for decoration/renovation is extremely dangerous and therefore is strictly forbidden. Customer can apply for temporary supply for decoration/renovation. The installation shall be protected by a residual current device complete with overcurrent protection main switch at the connection of supply.

3.9 **Application for Transfer**

1. We require one working day advance notice to process transfer of account. For most of the cases, we accept phone application/application by electronic form available from our website www.hkelectric.com for transfer and the process can be completed the next working day. A meter reading will be taken on the specified transfer date after which the customer will be responsible for the electricity consumption of the account. In case the customer has already occupied the address for a period of time, the date of the last monthly meter reading would be used in the transfer of account. The meter reading date is shown in the monthly electricity bill.
2. The completed Application Form For Supply/Transfer can also be returned to our Customer Centre by post or in person or by fax to 2510 7667. HK Electric will inform the customer of the deposit amount by letter.
3. No service charge is required for an application for transfer of account.
4. For details of deposit amount for a transfer of account, please call our Customer Services Executives at 2887 3411 during office hours.
5. When the transfer of account has been completed, the account of the former registered customer will be closed and the deposit will normally be ready for refund.

3.10 **Additional Information**

1. The time scales mentioned in the above sections are for indication only and HK Electric is not committed to provide supply by any prescribed date although every effort will be made to provide supply as early as possible.

2. The actual time needed to plan and install any plant required for provision of a supply depends on many factors such as the network situation, the working condition on site, availability of necessary permits issued by relevant government authority/private land owner (Excavation Permit, Government Lands Permit, Hong Kong Police Force Roadworks Advice, Construction Noise Permit and written approval from private land owners), etc.

Should there be any delay in provision of cable entry ducts and other facilities as required, HK Electric would not be able to complete the required excavation work within the period co-ordinated with other utility undertakers and approved by the relevant government authority and this could lead to a long delay in provision of supply due to the imposed restrictions on extension or re-application of excavation permit. Please refer to the leaflet, “Information on Application for Excavation Permit” as shown in Drg. No. GCS/3/26, prepared by HK Electric for more information.

3. If it is necessary to install any plant required for provision of supply, a Planning Number will be assigned to the scheme. The applicant or REC/REW should quote the Planning Number or the Application Number when making any enquiries regarding the supply.

3.11 Schedule of Drawings - Information on Application for Supply

<u>Drawing No.</u>	<u>Drawing Title</u>
GCS/3/01	Workflow and Telephone Contact List for Application of Additional Load
GCS/3/02	Workflow of Application for Construction Site Temporary Supply
GCS/3/03	Squatter Hut Central Metering Scheme (P274/94/R-1)
GCS/3/04	Typical Supply Arrangement for Pontoon/Vessel/Boat
GCS/3/05	Requirements for Service Cutout (LV RMU Type) in New Building/Premises (P427/99/R-8) (Total 2 sheets)
GCS/3/06	Details of Cable Entry Facilities in Existing Building for Cutout Installation (P53/89/R-2)

GCS/3/07	Space Requirements for 400-A Service Cutout in Existing Building and Locations without Switchroom (Switch Type and with Disconnection Link) (P213/92/R-5)
GCS/3/08	Typical Details of Fire Resisting Enclosure for HK Electric Service Cutout Under the Fire Safety (Commercial Premises) Ordinance or Fire Safety (Buildings) Ordinance (P707/11/R-1)
GCS/3/09	Installation of Mild Steel Weatherproof Enclosure for Site Services (up to 400 A) (P661/08) (Total 3 sheets)
GCS/3/10	Space Requirements for Stainless Steel Weather-proof Enclosure for Village House on Lamma Island (P72/89/R-8)
GCS/3/11	Transformer Pillar Foundation (For T.P. in Construction Site with RTU) (P505/00/R-2)
GCS/3/12	Typical Layout for 1 - Tx. Substation with HV Cable Pit (P512/00/R-9) (Total 9 sheets)
GCS/3/13	Typical Layout for Twin Transformer Substation with HV Cable Pit (P584/03/R-3) (Total 4 sheets)
GCS/3/14	Typical Layout for Single Transformer First Level Substation with HV & LV Compartments (P381/98/R-6) (Total 6 sheets)
GCS/3/15	Bund Wall and Flood Gate for Distribution Substation (P806/19) (Total 2 sheets)
GCS/3/16	Details of LV Transit Block at Mid Level (P314/96/R-3)
GCS/3/17	Arrangement for Single-Core Cables Connected to HK Electric Substation (Customer Main Switch Not Exceeding 2250 A) (P31/88/R-6)
GCS/3/18	Typical Design of Working Platform at Cable Shaft / Cable Compartment for First Level Substation (P605/04/R-4)
GCS/3/19	Earthing Bracket for New Substation (P574/02/R-2)

GCS/3/20	Substation Main Supply & Schematic Diagram (P561/01/R-10)
GCS/3/21	Typical Arrangement of Cable Entry Ducts in Substation (P627/05/R-1) (Total 2 Sheets)
GCS/3/22	Typical Arrangement of Cables and Cable Cleats in Riser Duct (Vertical Height \leq 7 Metres) (P671/08/R-3) (Total 2 sheets)
GCS/3/23	Typical Arrangement of Cables and Cable Cleats in Riser Duct for Upper Floor Substation or Basement Substation with Level Difference Exceeding 7 Metres (P666/08/R-4) (Total 2 sheets)
GCS/3/24	High Level Hazard Zone (P346/97)
GCS/3/25	Substation Louvres Details (P638/06/R-1)
GCS/3/26	Information on Application for Excavation Permit (Total 2 sheets)
GCS/3/27	Mild Steel Weatherproof Enclosure for Site Services up to 100 A 3-Phase (P630/06/R-2) (Total 4 sheets)
GCS/3/28	Conditions on Acceptance of Attaching External Decorative Louvres / Cladding to Substation Door or Additional Decorative Door in Front of Substation Door of Ground Floor Substation (P753/14/R1)
GCS/3/29	Requirements on Fire Resisting Door for Substations (P339/97/R-7)
GCS/3/30	Requirements of Precast Reinforced Concrete Cover (P722/12/R-1)
GCS/3/31	Anchoring Eye and Facilities for First Level Substation (P342/97/R-3) (Total 2 sheets)
GCS/3/32	Arrangement for Tariff Meter Communication (TMC) Termination Box (P383/98/R-6) (Total 2 sheets)

GCS/3/33 Mild Steel Weather-proof Enclosure for Single-Phase Supply (P655/07/R-3)

GCS/3/34 Mild Steel Weather-proof Enclosure for Single-Phase Supply to Hawker Stall (P717/12/R-3) (Total 2 sheets)

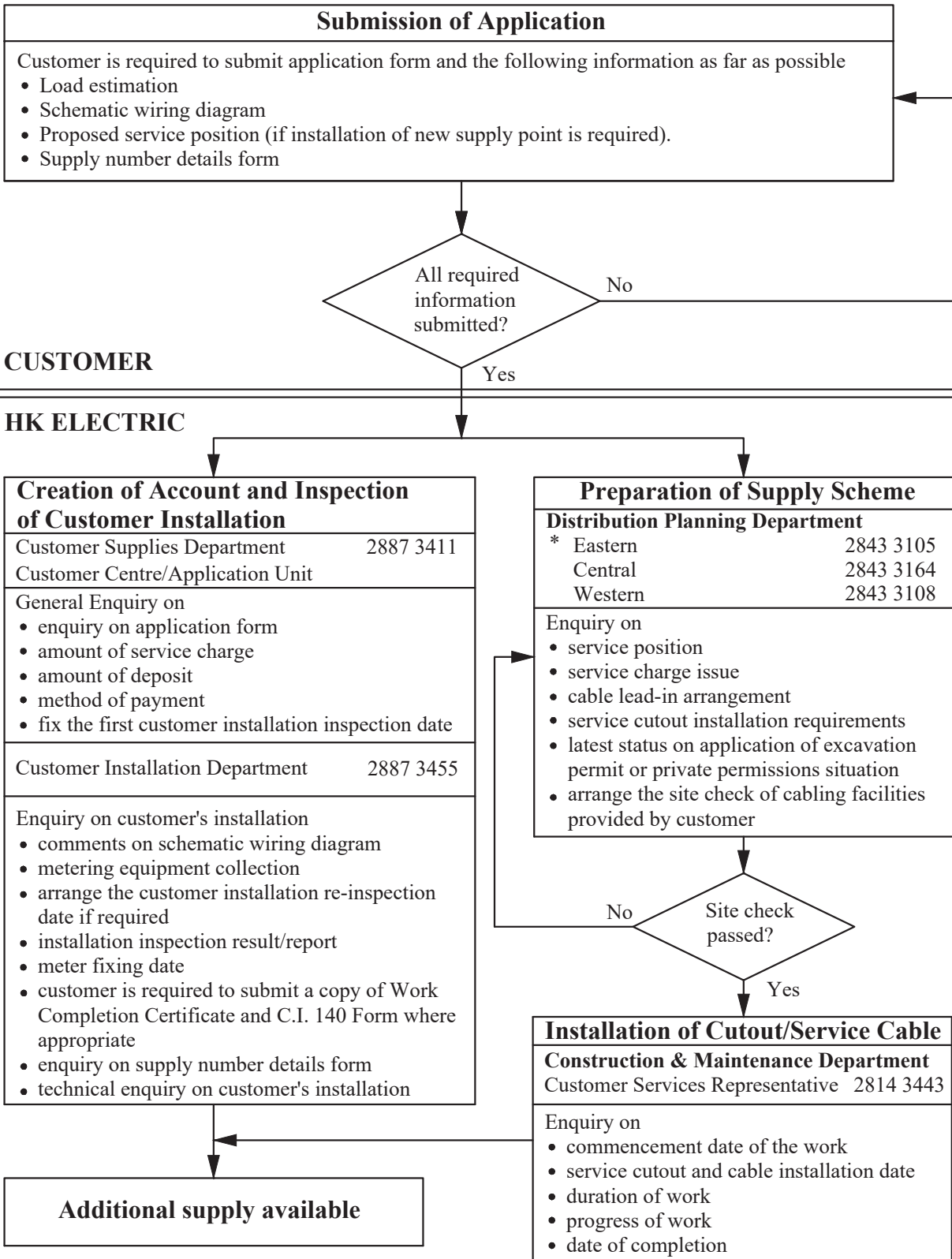

Remark : Please contact the corresponding department or call our Electricity-By-Phone Service at telephone No. 2887 3838 if you have any queries regarding the progress of application.

Drg. No. GCS/3/01
WORKFLOW AND TELEPHONE CONTACT LIST
FOR APPLICATION OF ADDITIONAL LOAD

For application and enquiry for construction site temporary supply, please call
Smart Power for Construction Site hotline **2510 2701** or email to **SPCS@hkelectric.com**

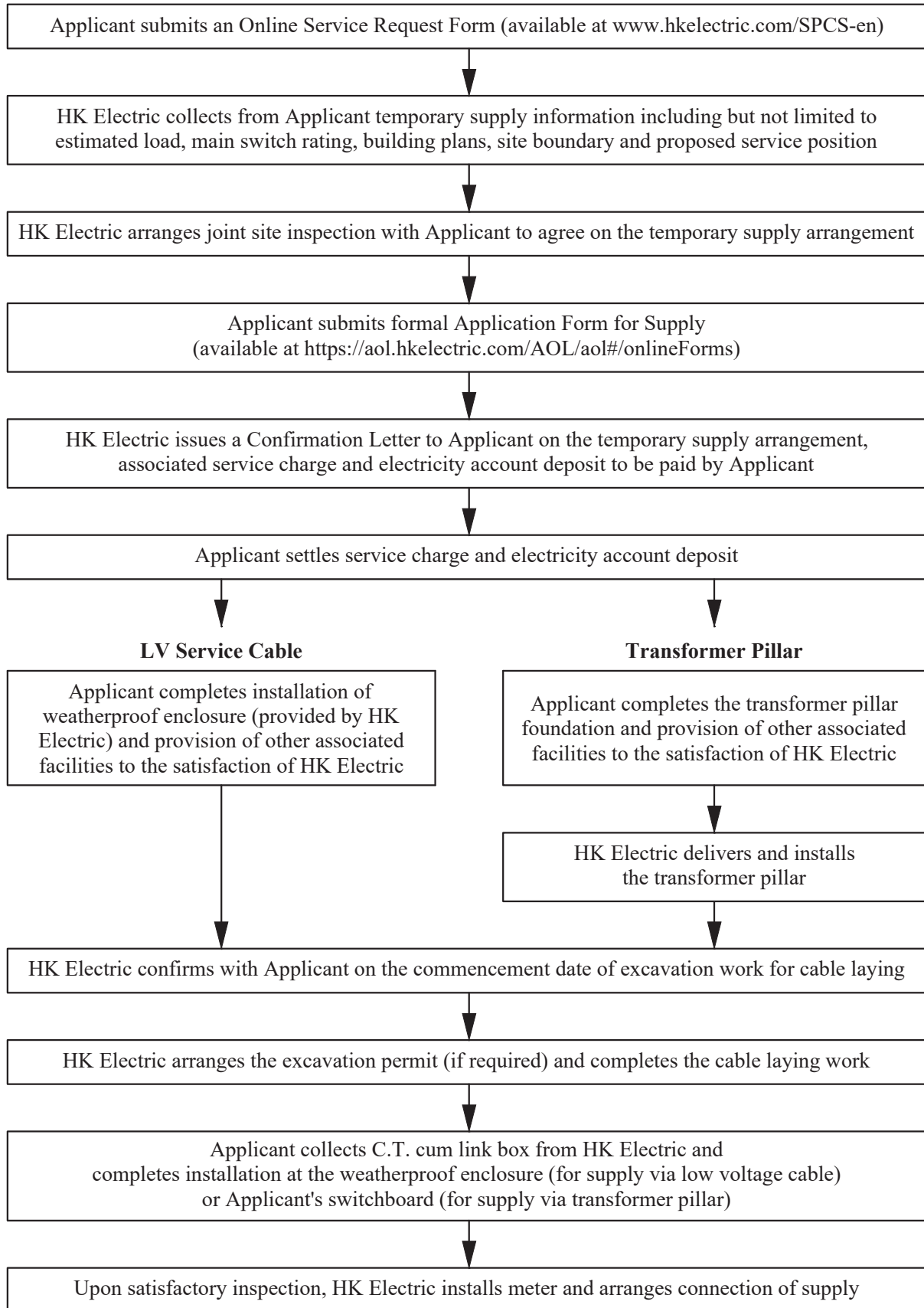

Drg. No. GCS/3/02
WORKFLOW OF APPLICATION FOR CONSTRUCTION SITE
TEMPORARY SUPPLY

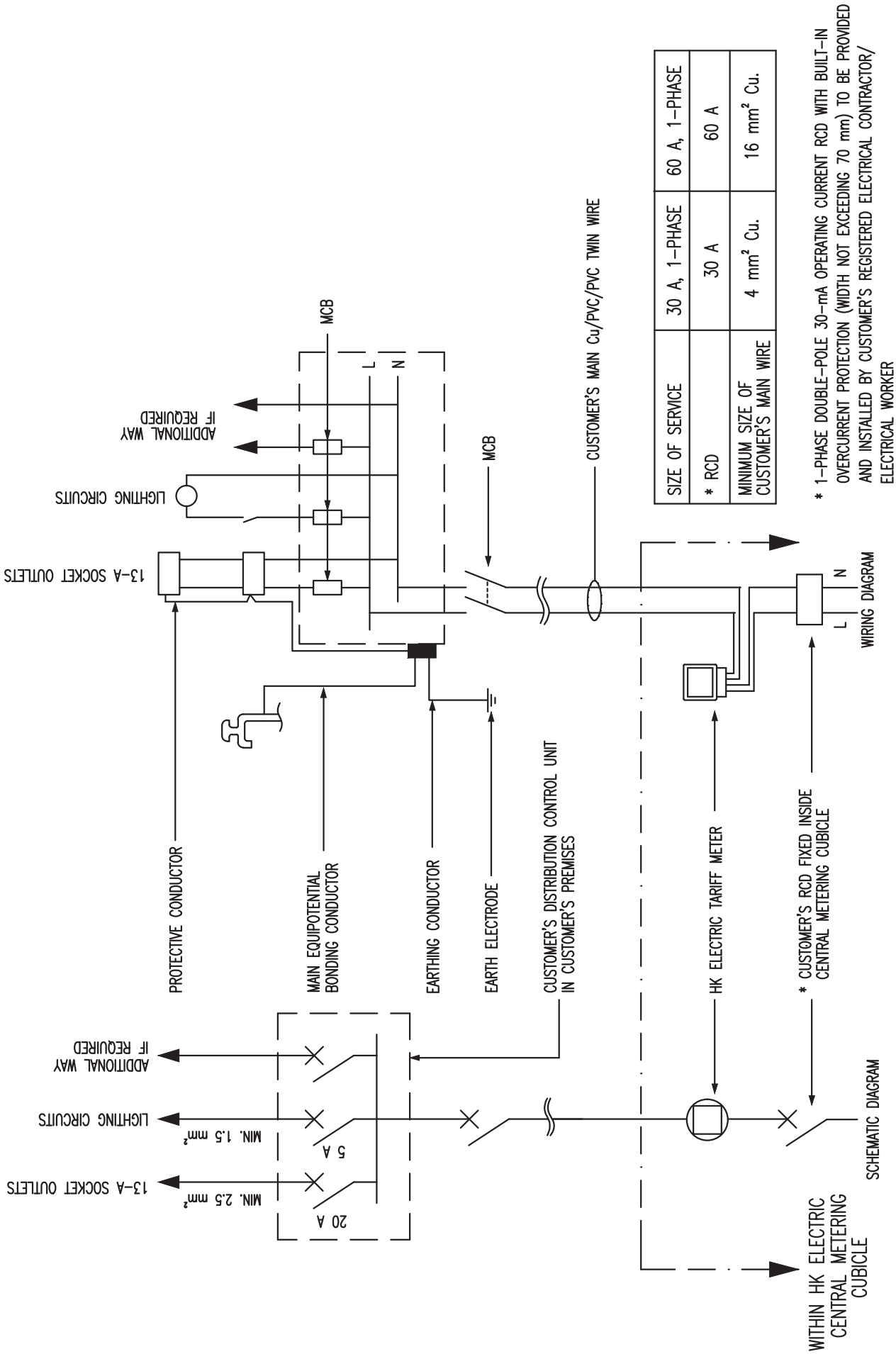

Drg. No. GCS/3/03

SQUATTER HUT CENTRAL METERING SCHEME (P274/94/R-1)

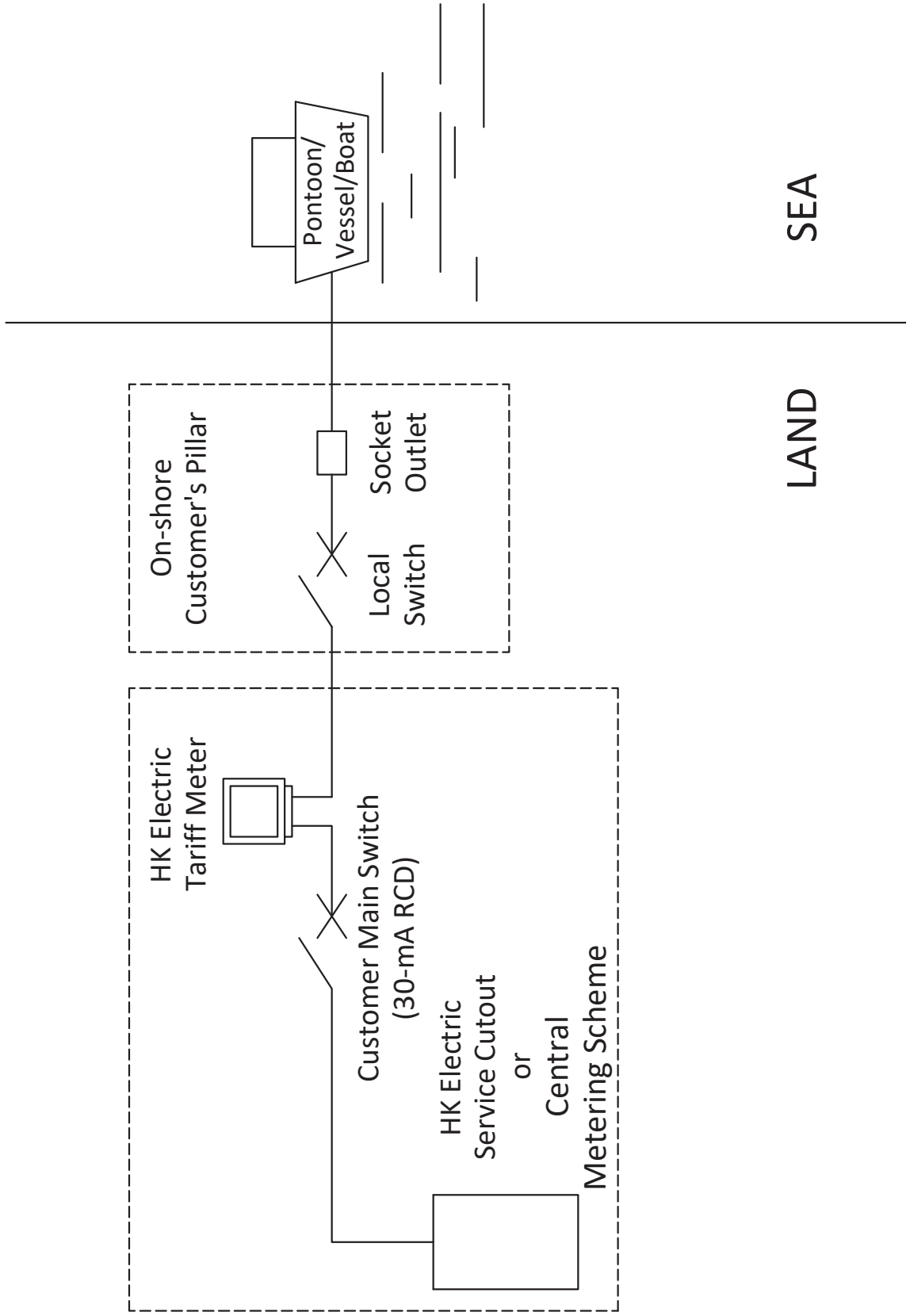

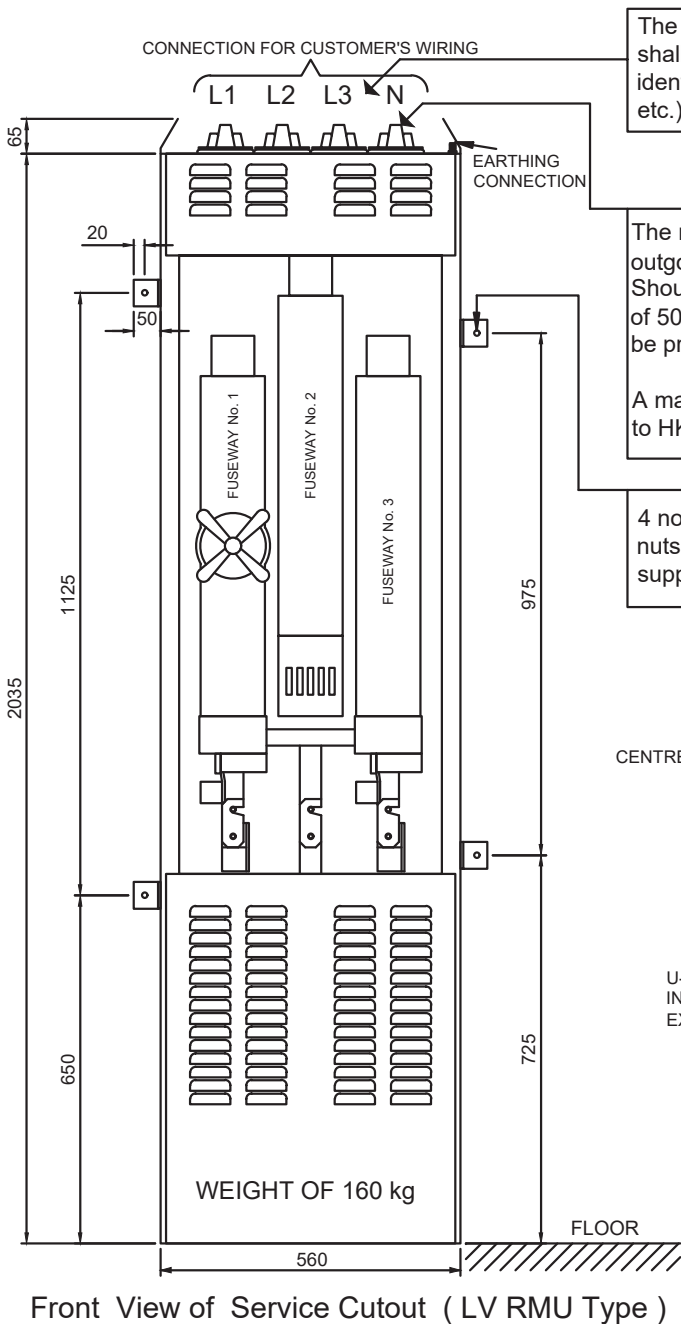

The cable ends terminated onto HK Electric service cutout shall be fitted with proper, durable and legible phase identification labels (such as cable ties, sleeves, ferrules etc.) marked in L1, L2, L3 and N.

The minimum size of copper conductor to be terminated onto the outgoing service terminals of HK Electric service cutout is 50 mm². Should the customer's main wiring be less than this size, a copper collar of 50 mm² (by hydraulic crimping or by mechanical connection) should be provided for termination onto HK Electric service cutout.

A maximum of two (2) sets of customer's wiring to be connected directly to HK Electric service cutout.

4 nos. mounting bracket (4 nos. M10 G.I. expansion anchor bolts with nuts & washers with protruded length of 50 mm from wall surface , to be supplied & installed by customer)

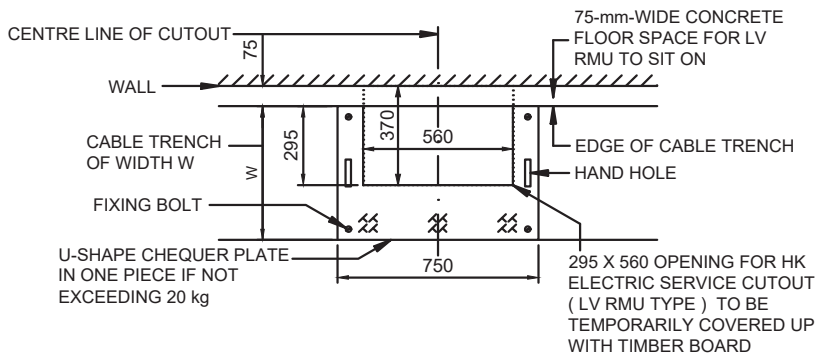

Typical Layout of Chequer Plates
For HK Electric Service Cutout

NOTE : ALL DIMENSIONS ARE IN mm.

Drg. No. GCS/3/05
**REQUIREMENTS FOR SERVICE CUTOUT (LV RMU TYPE) IN
NEW BUILDING/PREMISES (P427/99/R-8) SHEET 1 OF 2**

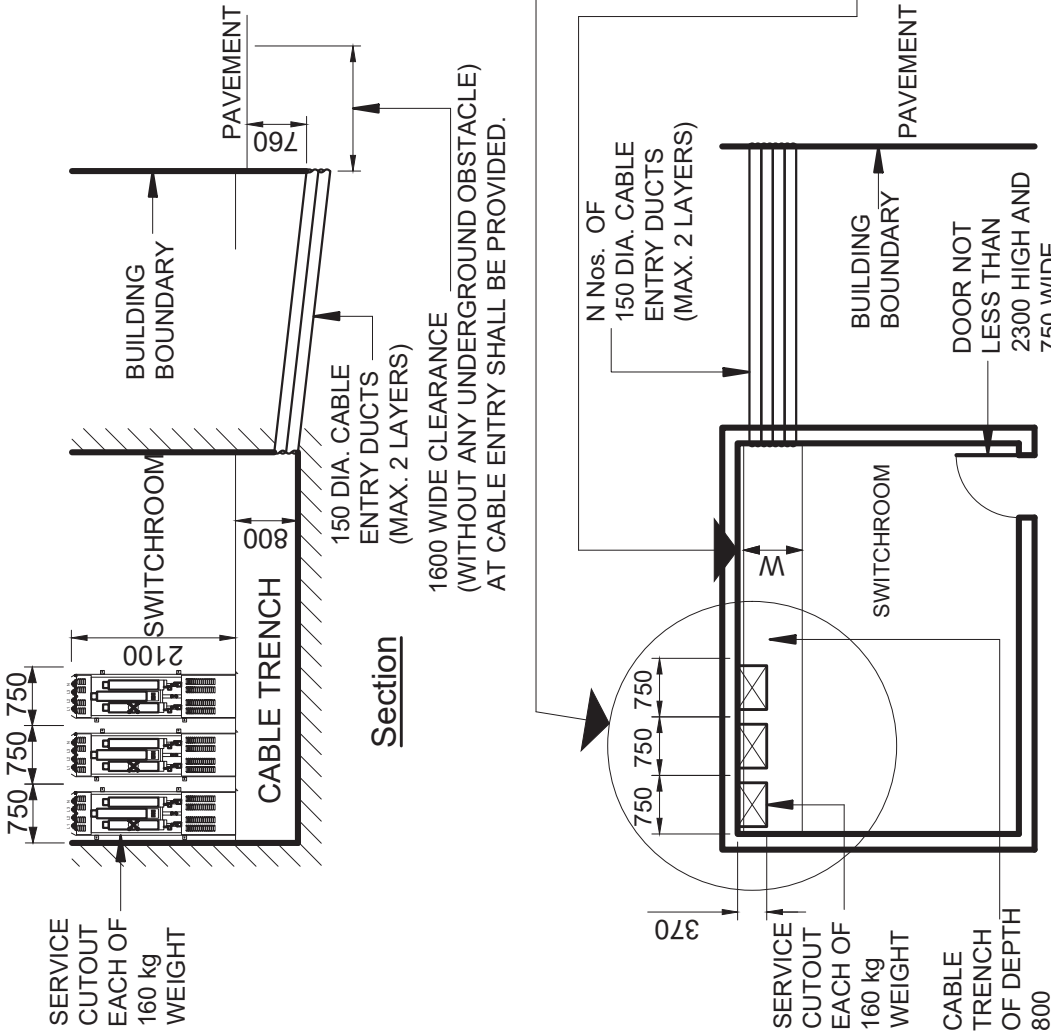

Customer shall provide chequer plates to cover trench opening.

The chequer plates for each service cutout shall be of dimensions 750 mm X W, where W is the width of the cable trench. The chequer plates shall be in pieces forming area 750 mm X W in order that each piece shall not exceed 20 kg. The chequer plates shall be provided with hand holes, fixed by bolts and nuts and fitted with stiffeners if necessary.

The floor area measured 900 mm in front of each service cutout and measured 600 mm from both left hand side and right hand side (if not obstructed by the wall or door) of the centre line of each service cutout shall be of concrete floor or covered with chequer plates to facilitate the cutout installation work by HK Electric.

Floor space of 75 mm wide shall be provided between wall and edge of cable trench for LV RMU to sit on.

In case the width of this floor space exceeds 75 mm, customer shall construct a robust framework of hot dip galvanised steel to be mounted on wall so that the horizontal separation of framework and edge of trench will be 75 mm.

Holes of 14 mm dia. together with M10 bolts, nuts and washers shall be provided on the framework to suit the 4 nos. mounting bracket at the service cutout.

NOTE : ALL DIMENSIONS ARE IN mm.

Part of Ground Floor Plan of a Typical Building

Dr. No. GCS/3/05
REQUIREMENTS FOR SERVICE CUTOUT (LV RMU TYPE) IN
NEW BUILDING/PREMISES (P427/99/R-8) SHEET 2 OF 2

Notes for Drawing No. GCS/3/05

1. This drawing shows the typical layout of cable entry facilities in buildings where there is no underground obstacles. All dimensions shown in this drawing are in mm (millimetre).
2. Reinstatement of excavation surfaces required for provision of cable entry facilities and cable laying work by **The Hongkong Electric Co. Ltd.** 香港電燈有限公司 within the building lot boundary shall be the responsibility of customers.
3. The cable entry facilities shall be sealed properly by customers against ingress of water to the switchroom and other parts of the building during the excavation work by customers and after HK Electric new cables are installed.
4. All excavation work by customers shall be carried out within the building lot boundary. It is unlawful to excavate in public road and footway outside the building lot boundary without prior approval of the Government Highways Department.
5. A minimum clearance space of 900 mm for the full width and in front of HK Electric service cutouts and customer's switchgear shall be provided.
6. Where there is spare space on wall of switchroom for contingency service cutout (please refer to the returned marked-up copy of Ground Floor Plan), the spare space shall be painted in red with an engraved label not less than 150 mm wide x 75 mm high stating

"SPACE RESERVED FOR HK ELECTRIC CONTINGENCY SERVICE CUTOUT" with Chinese translation, 「應急熔斷器之預留空間」 being securely fixed on the wall space.
7. Normally, HK Electric will install service cutouts at the positions furthest from the cable entry ducts. Spare spaces for contingency service cutouts will be the closest from the cable entry ducts.
8. The number of cable entry ducts and width of cable trench shall be provided according to the following table, unless otherwise specified.

No. of Service Cutout Spaces (including spare, if any)	No. of Cable Entry Ducts (N)	Width of Cable Trench (W)
1	4	500 mm
2	6	600 mm
3	8	750 mm

Notes for Drawing No. GCS/3/05

9. A minimum clearance of 1600 mm wide (without any underground obstacle) immediately in front of the cable entries should be provided for cable installation. Where necessary the architect shall be responsible for clearing underground obstacles with other utility companies before hand-over of the switchroom to HK Electric for cable installation.
10. The door of switchroom shall not be less than 750 mm wide by 2300 mm high measured clear of obstacles.

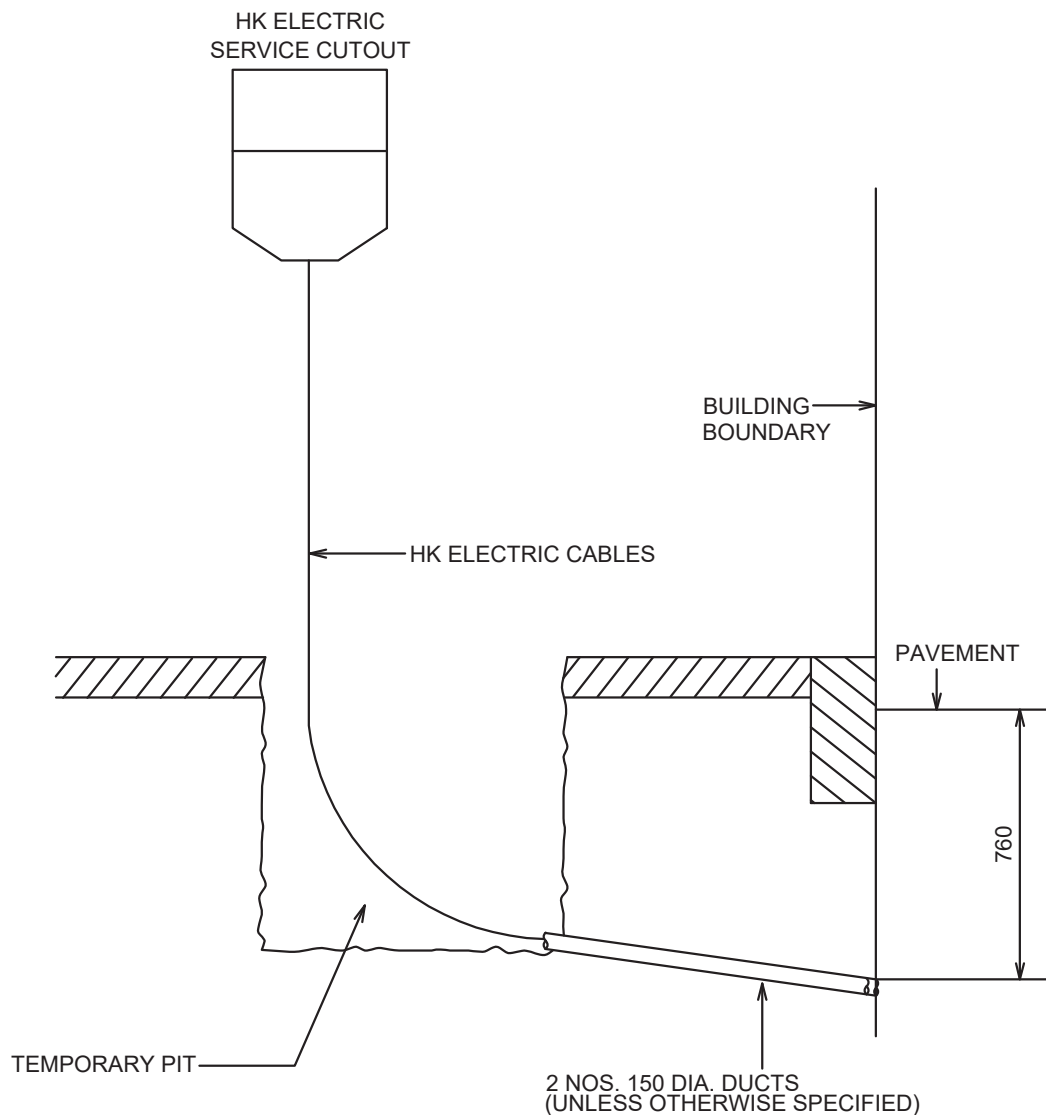

GENERAL NOTES:

1. This drawing shows the typical layout of cable entry facilities in buildings where there is no underground obstacles. All dimensions shown in this drawing are in mm (millimetre).
2. Unless otherwise specified, 2 nos. of 150-mm-diameter ducts shall be provided for cable entry.
3. Reinstatement of excavation surfaces required for provision of cable entry facilities and cable laying work by The Hongkong Electric Co. Ltd. within the building lot boundary shall be the responsibility of customers.
4. The temporary pit shall be backfilled by customers. All pits and trenches within the building lot boundary shall be filled up temporarily with sand bags and be covered in proper condition in order to avoid hazards endangering residents in the building.
5. The cable entry facilities shall be sealed properly by customers against ingress of water to other parts of the premises during the excavation work by customers and after HK Electric new cables are installed.
6. All excavation work by customers shall be carried out within the building lot boundary. It is unlawful to excavate in public road and footway outside the building lot boundary without prior approval of the Government Highways Department.

Drg. No. GCS/3/06
DETAILS OF CABLE ENTRY FACILITIES IN EXISTING BUILDING
FOR CUTOUT INSTALLATION (P53/89/R-2)

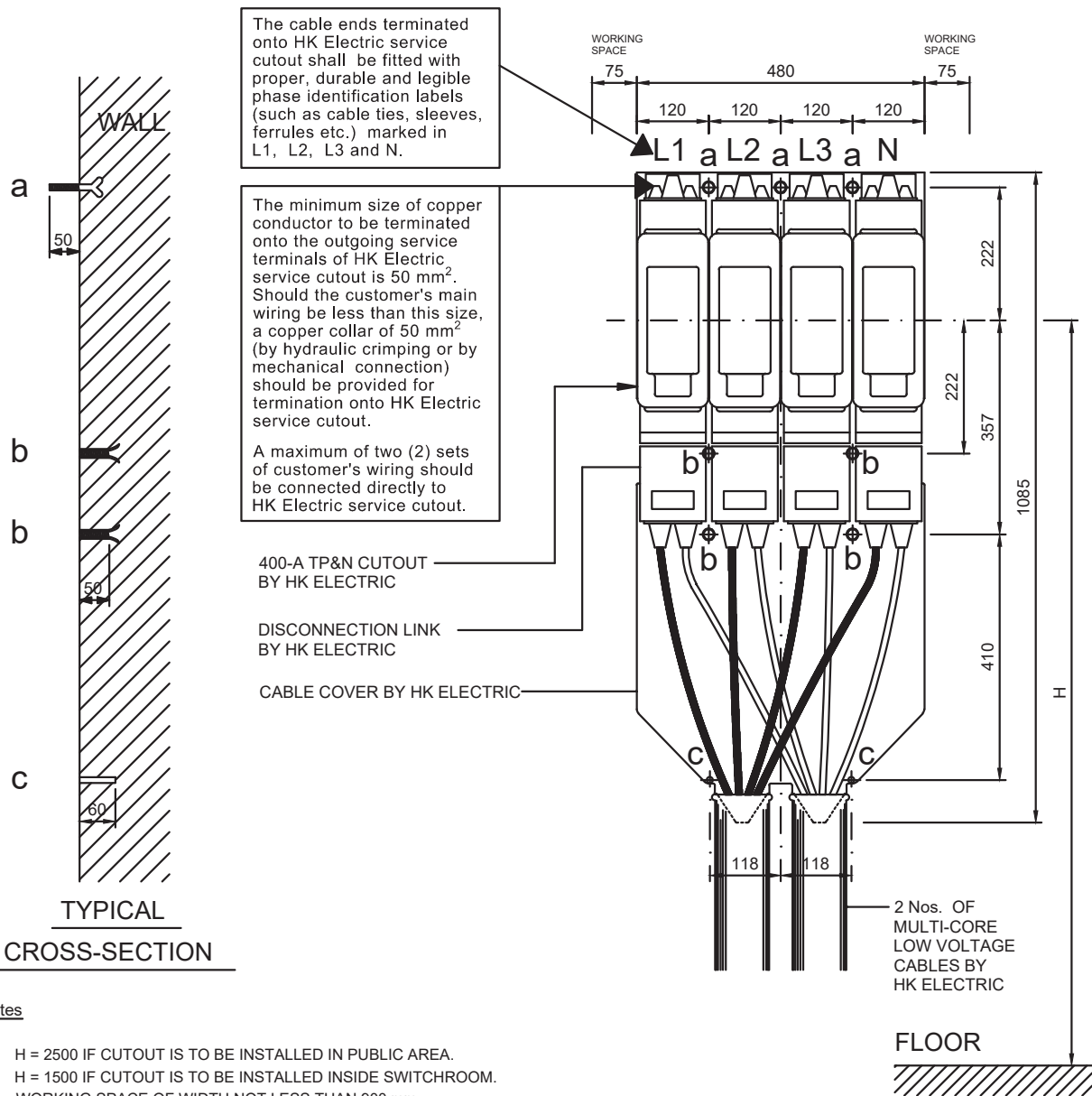

TYPICAL CROSS-SECTION

FRONT VIEW

Notes

- H = 2500 IF CUTOUT IS TO BE INSTALLED IN PUBLIC AREA.
H = 1500 IF CUTOUT IS TO BE INSTALLED INSIDE SWITCHROOM.
- WORKING SPACE OF WIDTH NOT LESS THAN 900 mm SHALL BE PROVIDED IN FRONT OF THE CUTOUT.
- PROTRUSION OF CUTOUT IS 320 mm.
- EXTERNAL SURFACE OF CUTOUT IS MADE OF INSULATED MATERIAL.
- CUSTOMER IS REQUIRED TO PASTE THE SCALE 1 : 1 TEMPLATE No. EQE-16306-L ON THE WALL TO FACILITATE THEIR DRILLING WORK ON WALL AND THE INSPECTION BY HK ELECTRIC.
- NO ENCLOSURE IS ALLOWED TO BE INSTALLED TO COVER UP THE CUTOUT AND LV CABLES UNLESS IT IS REQUIRED TO MEET FSD'S REQUIREMENTS. IF INSTALLATION OF THE ENCLOSURE IS REQUIRED, THE ENCLOSURE SHALL HAVE REMOVABLE DESIGN AND IT SHALL BE THE RESPONSIBILITY OF CUSTOMER TO REMOVE THE ENCLOSURE AND PROVIDE A MINIMUM WORKING SPACE OF 900 mm IN FRONT OF THE CUTOUT FOR HK ELECTRIC OPERATIONAL NEEDS AND MAINTENANCE.
- ALL DIMENSIONS ARE IN mm.

ITEM	DESCRIPTION
a	3 Nos. M10 G.I. EXPANSION ANCHOR BOLTS WITH NUTS & WASHERS WITH PROTRUDED LENGTH OF 50 mm FROM WALL SURFACE , TO BE SUPPLIED AND INSTALLED BY CUSTOMER.
b	4 Nos. M10 G.I. EXPANSION ANCHOR WITH 50 mm BOLTS & WASHERS TO BE FLUSH WITH WALL SURFACE , TO BE SUPPLIED AND INSTALLED BY CUSTOMER.
c	2 Nos. OF ϕ 10 mm HOLES (60 mm DEEP) TO BE DRILLED ON WALL BY CUSTOMER.

Drg. No. GCS/3/07

SPACE REQUIREMENTS FOR 400-A SERVICE CUTOUT IN EXISTING BUILDING AND LOCATIONS WITHOUT SWITCHROOM (SWITCH TYPE AND WITH DISCONNECTION LINK) (P213/92/R-5)

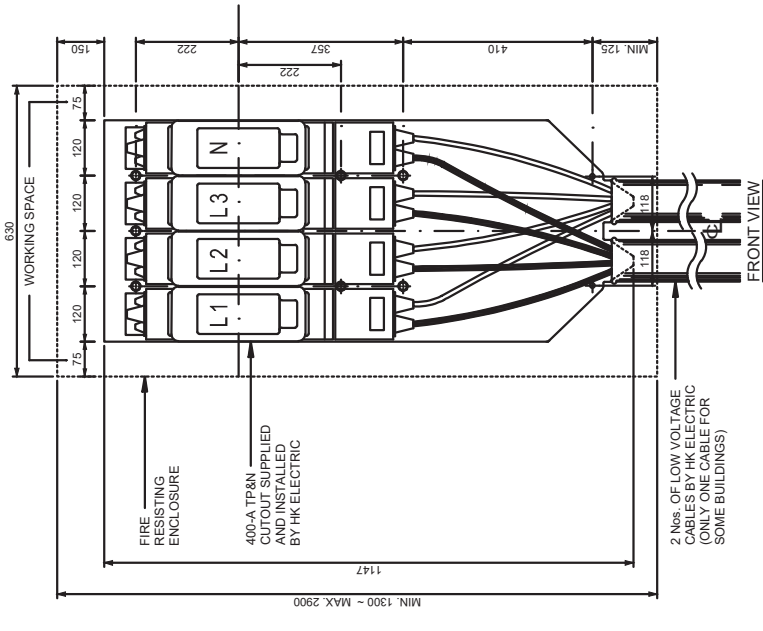
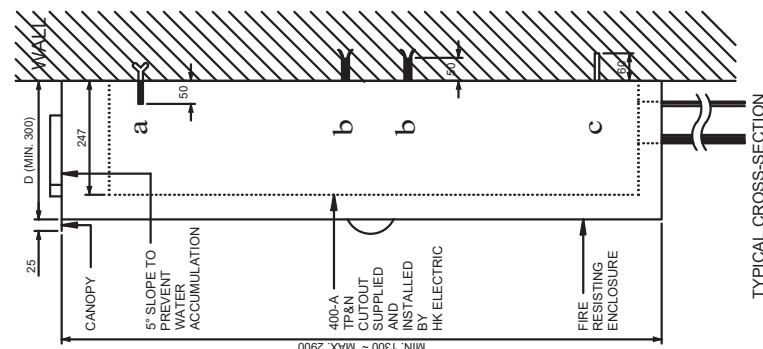
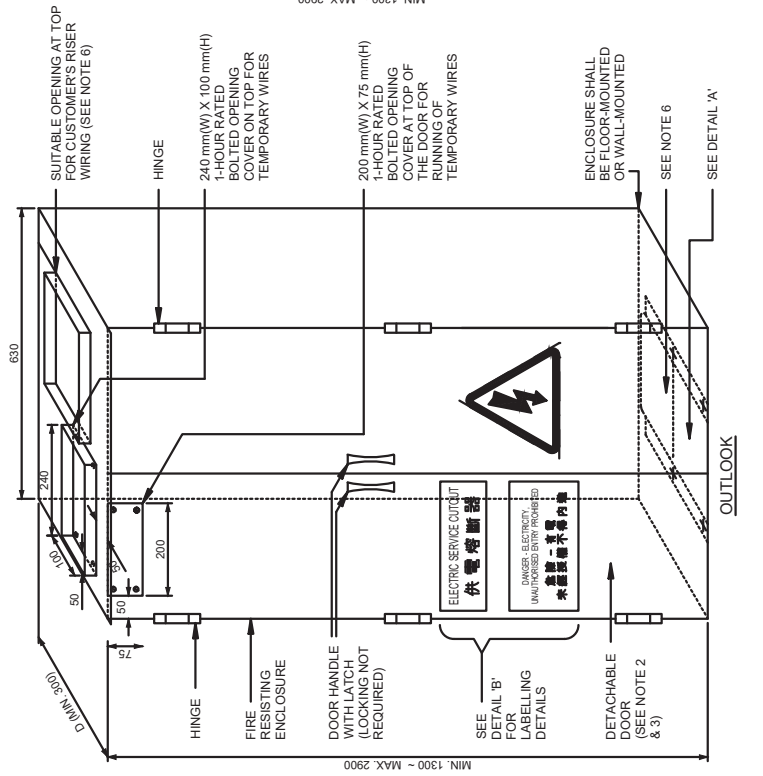

NOTES :

1. WORKING SPACE OF WIDTH NOT LESS THAN 900 mm SHALL BE PROVIDED IN FRONT OF HK ELECTRIC SERVICE CUTOFF.
2. THE DOOR SHALL BE WITH FULL SWING 180 DEGREE. THE DOOR SHALL BE DETACHABLE AND CAN ONLY BE DETACHED BY PUSHING UPWARDS WITHOUT ANY TOOL WHEN IT HAS BEEN OPENED FOR MORE THAN 30 DEGREE.
3. THE TOTAL WEIGHT OF EACH REMOVABLE DOOR SHALL NOT EXCEED 10 kgf.
4. THE ENCLOSURE SHALL NOT HINDER OR OBSTRUCT OPERATION AND MAINTENANCE OF HK ELECTRIC SERVICE CUTOFF.
5. THE FIRE RESISTING ENCLOSURE SHALL BE CONSTRUCTED TO HAVE A FIRE RESISTING PERFORMANCE OF 120 MINUTES IN ACCORDANCE TO BOTH INTEGRITY AND INSULATION, COMPLYING WITH FSD REQUIREMENTS AND RELEVANT GOVERNMENT REGULATIONS.
6. THE OPENINGS FOR CUSTOMER RISER WIRE ENTRY FROM TOP AND HK ELECTRIC CABLE ENTRY FROM BOTTOM OF THE FIRE RESISTING ENCLOSURE SHALL BE PROPERLY SEALED WITH FIRE RETARDANT MATERIALS BY CUSTOMER AFTER CABLE INSTALLED.
7. THE WHOLE BASE PLATE SHOULD BE COMPLETELY REMOVABLE FOR EASY CABLE LAYING AND CABLE TERMINATION.

8. THE OWNER OF THE ENCLOSURE SHALL SUBMIT A CONFIRMATION LETTER TO HK ELECTRIC UNDERTAKING THE FUTURE MAINTENANCE OF THE ENCLOSURE.
9. DEPTH OF HK ELECTRIC SERVICE CUTOFF IS 247 mm. THE MINIMUM DEPTH OF THE ENCLOSURE SHALL BE 300 mm.
10. FIRE RATED MATERIAL WITH TRANSPARENT GLASS AND ACCESS PANEL SHALL BE 1-HOUR FIRE RATED WITH REGARD TO BOTH INTEGRITY AND INSULATION.
11. EXTERNAL SURFACE OF HK ELECTRIC SERVICE CUTOFF IS MADE OF FLAME RETARDANT INSULATED MATERIAL TO USA STANDARD UL94-V0.
12. EXCEPT IN COMPLIANCE WITH TABLES A TO F OF THE CODE OF PRACTICE FOR BUILDINGS, THE ENCLOSURE SHALL BE SUBMITTED TO THE BUILDINGS DEPARTMENT TO DEMONSTRATE THAT THE ENCLOSURE ACCESS PANEL MATERIAL OR CONSTRUCTION ARE CAPABLE OF RESISTING THE ACTION OF FIRE FOR THE SPECIFIED PERIOD UPON COMPLETION. OTHER RELEVANT REQUIREMENTS OF THE BUILDINGS ORDINANCE AND THE FIRE SAFETY (BUILDINGS) ORDINANCE CAP 572 SHOULD ALSO BE COMPLIED WITH.
13. THE CUSTOMER IS RESPONSIBLE TO REMOVE THE ENCLOSURE TO FACILITATE HK ELECTRIC OPERATIONAL NEEDS AND MAINTENANCE WHEN SO REQUIRED BY HK ELECTRIC.
14. ALL DIMENSIONS ARE IN mm.

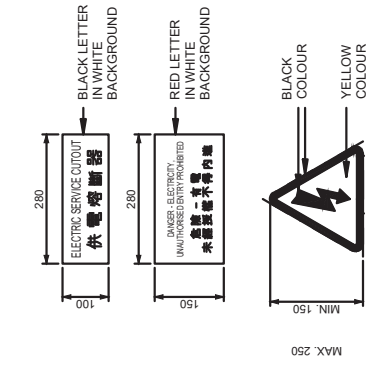
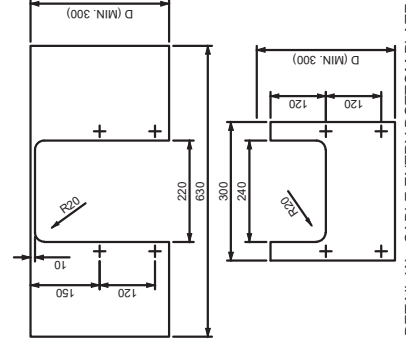

DETAIL 'A' - CABLE ENTRY BOTTOM PLATE

DETAIL 'B' - LABELLING REQUIREMENTS

Drg. No. GCS/3/08 TYPICAL DETAILS OF FIRE RESISTING ENCLOSURE FOR HK ELECTRIC SERVICE CUTOFF UNDER THE FIRE SAFETY (COMMERCIAL PREMISES) ORDINANCE OR FIRE SAFETY (BUILDINGS) ORDINANCE (P707/11/R-1)

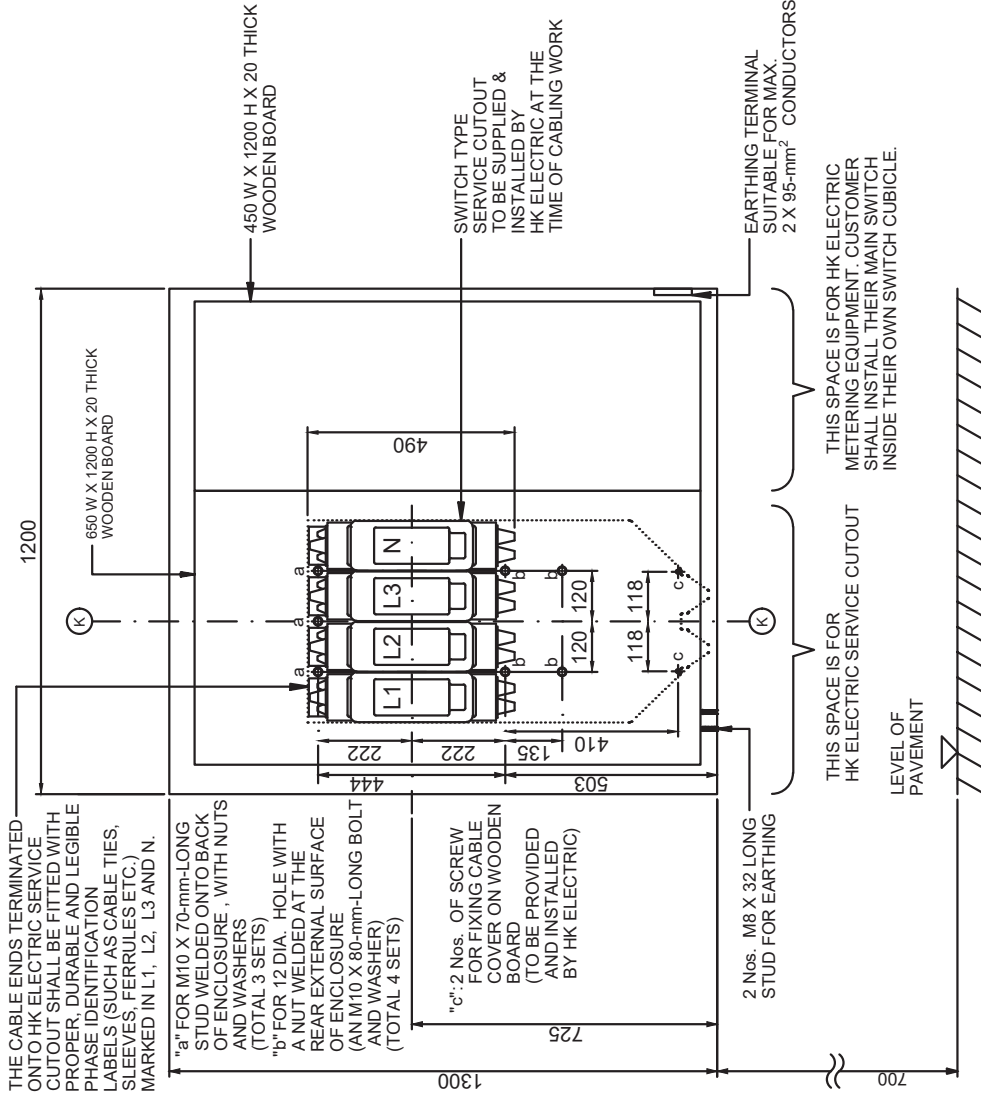

THE CABLE ENDS TERMINATED ONTO HK ELECTRIC SERVICE CUTOUT SHALL BE FITTED WITH PROPER, DURABLE AND LEGIBLE PHASE IDENTIFICATION LABELS (SUCH AS CABLE TIES, SLEEVES, FERRULES ETC.) MARKED IN L1, L2, L3 AND N.

"a": FOR M10 X 70-mm-LONG STUD WELDED ONTO BACK OF ENCLOSURE, WITH NUTS AND WASHERS (TOTAL 3 SETS)
 "b": FOR 12 DIA. HOLE WITH A NUT WELDED AT THE REAR EXTERNAL SURFACE OF ENCLOSURE (AN M10 X 80-mm-LONG BOLT AND WASHER) (TOTAL 4 SETS)

"c": 2 Nos. OF SCREW FOR FIXING CABLE COVER ON WOODEN BOARD (TO BE PROVIDED AND INSTALLED BY HK ELECTRIC)

2 Nos. M8 X 32 LONG STUD FOR EARTHING

THIS SPACE IS FOR HK ELECTRIC METERING EQUIPMENT. CUSTOMER SHALL INSTALL THEIR MAIN SWITCH INSIDE THEIR OWN SWITCH CUBICLE.

THIS SPACE IS FOR HK ELECTRIC SERVICE CUTOUT

LEVEL OF PAVEMENT

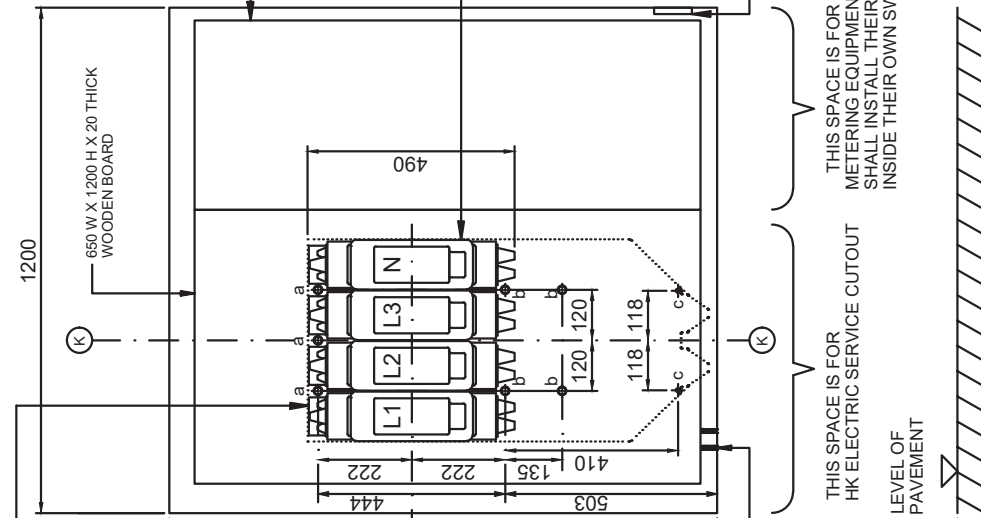

LOCATION PLAN

NOTE : ALL DIMENSIONS ARE IN mm.

INTERNAL LAYOUT OF WEATHERPROOF ENCLOSURE

Drg. No. GCS/3/09

INSTALLATION OF MILD STEEL WEATHERPROOF ENCLOSURE FOR SITE SERVICES
 (UP TO 400 A) (P661/08) SHEET 1 OF 3

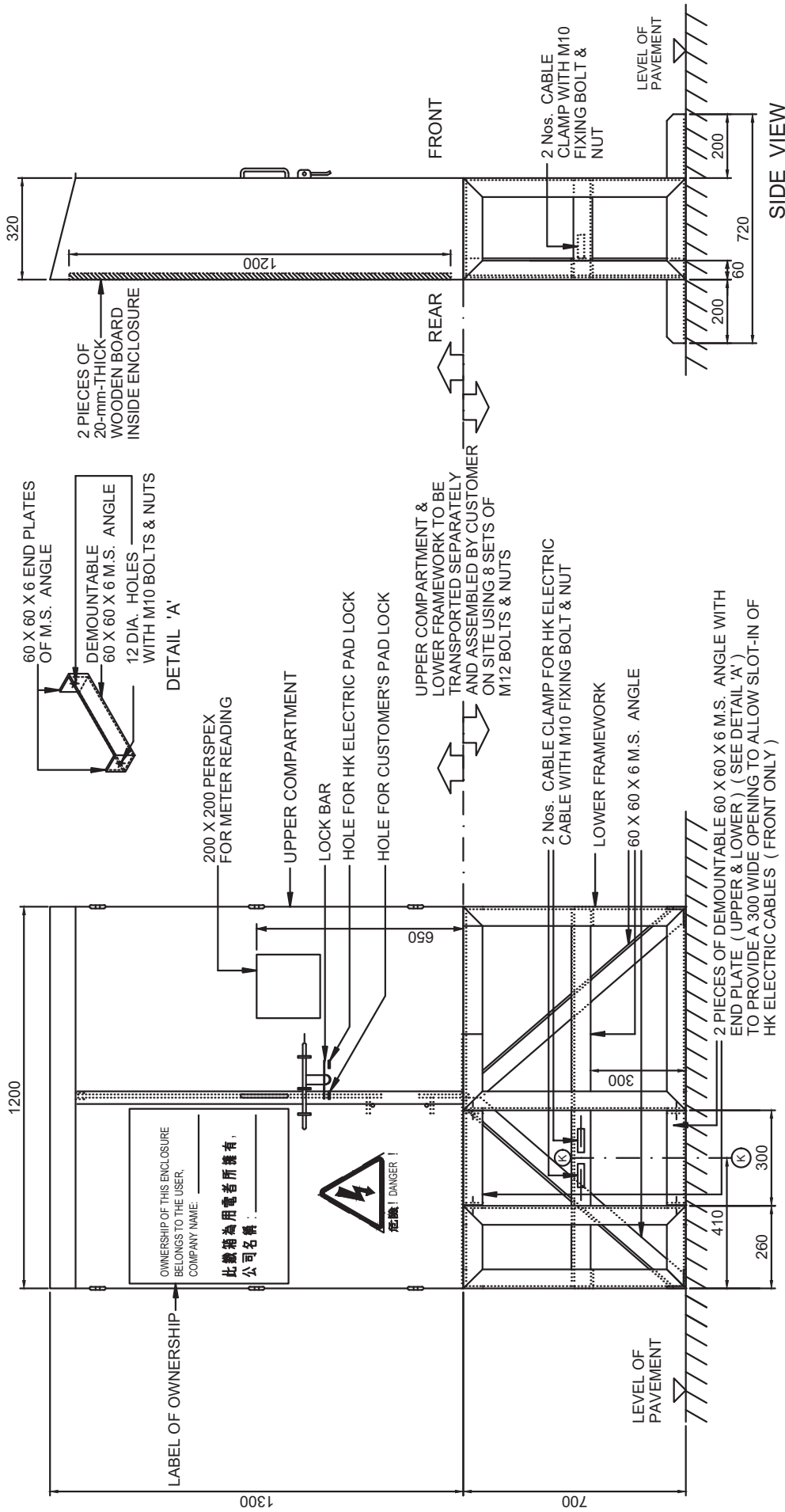

NOTE : ALL DIMENSIONS ARE IN mm.

Drg. No. GCS/3/09
INSTALLATION OF MILD STEEL WEATHERPROOF ENCLOSURE FOR SITE SERVICES
 (UP TO 400 A) (P661/08) SHEET 2 OF 3

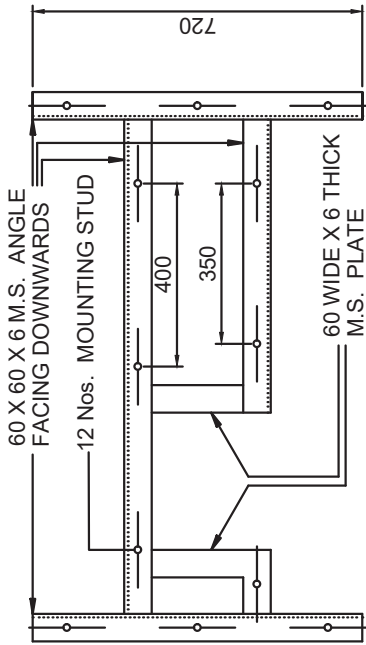

MOUNTING TEMPLATE (SUPPLIED BY HK ELECTRIC AND TO BE CAST IN CONCRETE PLINTH BY CUSTOMER)

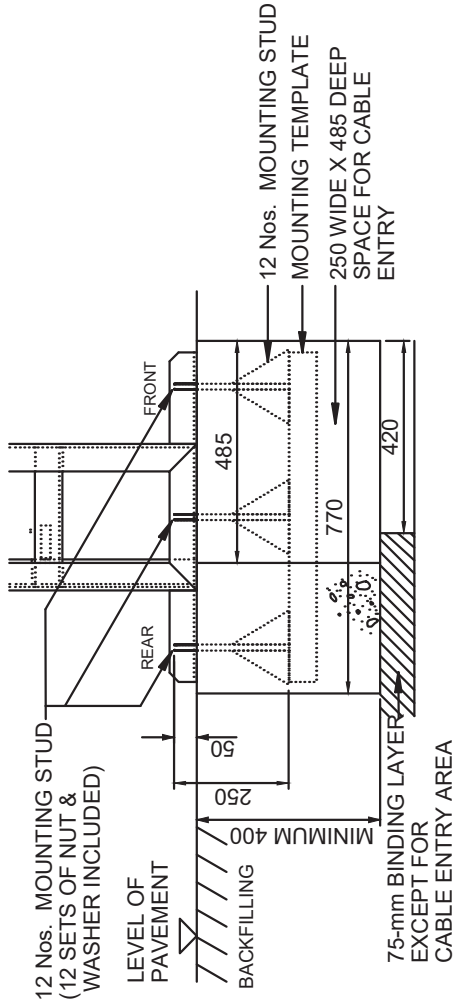

SECTION 'X' - 'X'

MOUNTING TEMPLATE INSTALLATION

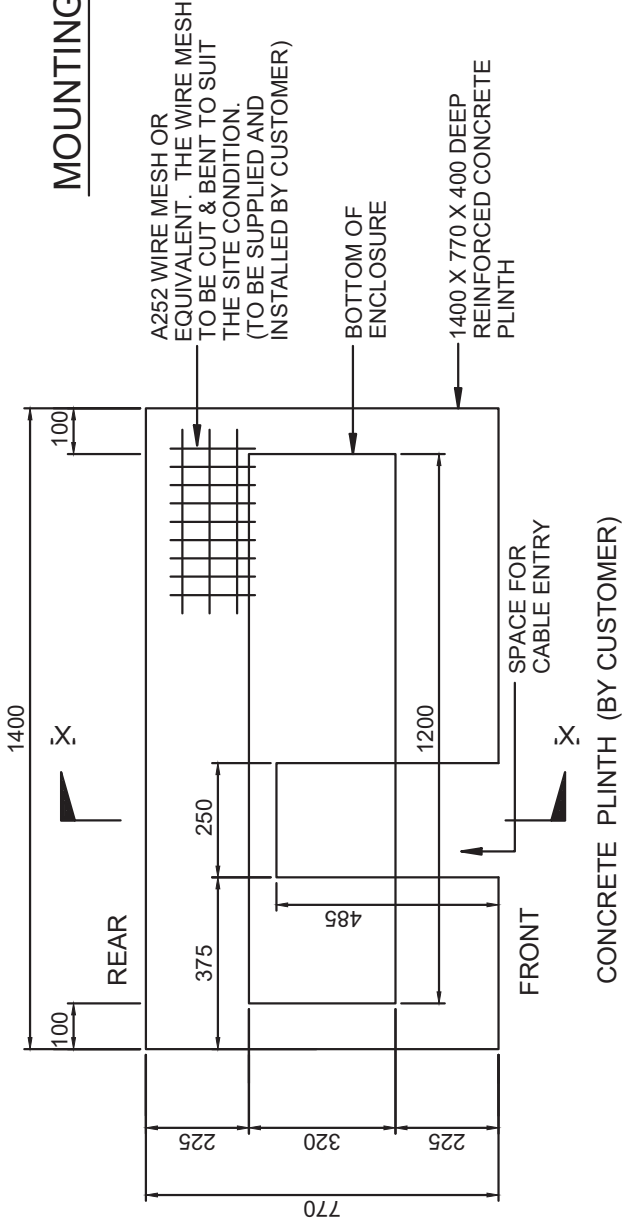

CONCRETE PLINTH (BY CUSTOMER)

NOTE : ALL DIMENSIONS ARE IN mm.

Drg. No. GCS/3/09

INSTALLATION OF MILD STEEL WEATHERPROOF ENCLOSURE FOR SITE SERVICES

(UP TO 400 A) (P661/08) SHEET 3 OF 3

Notes for Drawing No. GCS/3/09

1. A weatherproof enclosure comprising upper compartment, lower framework and mounting template provided by HK Electric shall be installed by customer on site.
2. The ownership of the weatherproof enclosure belongs to the customer after collection of the enclosure. Customer is required to write down the company name on enclosure at the space provided on the "LABEL OF OWNERSHIP".
3. Customer shall provide and install a switch cubicle adjacent to the weatherproof enclosure for housing customer main switch and associated installation.
4. The weatherproof enclosure and switch cubicle shall be installed inside the boundary of construction site and be facing the pavement as shown on the location plan. A minimum clearance space of 900 mm for the full width in front of enclosure shall be provided. A clear access to the enclosure shall be provided without any obstruction from covered walkway.
5. The mounting template shall be cast in a reinforced concrete plinth by customer.
6. The concrete shall be designed mix of grade 20/20D with compressive stress 20 N/mm² at 28 days.
7. The concrete cover to mesh reinforcement shall be 50 mm minimum.
8. Proper earthing of the weatherproof enclosure shall be by customer.
9. Customer is required to inform HK Electric for an inspection after completion of the weatherproof enclosure installation and their pad lock fitted.

THE CABLE ENDS TERMINATED ONTO HK ELECTRIC SERVICE CUTOUT SHALL BE FITTED WITH PROPER, DURABLE AND LEGIBLE PHASE IDENTIFICATION LABELS (SUCH AS CABLE TIES, SLEEVES, FERRULES ETC.) MARKED IN L1, L2, L3 AND N.

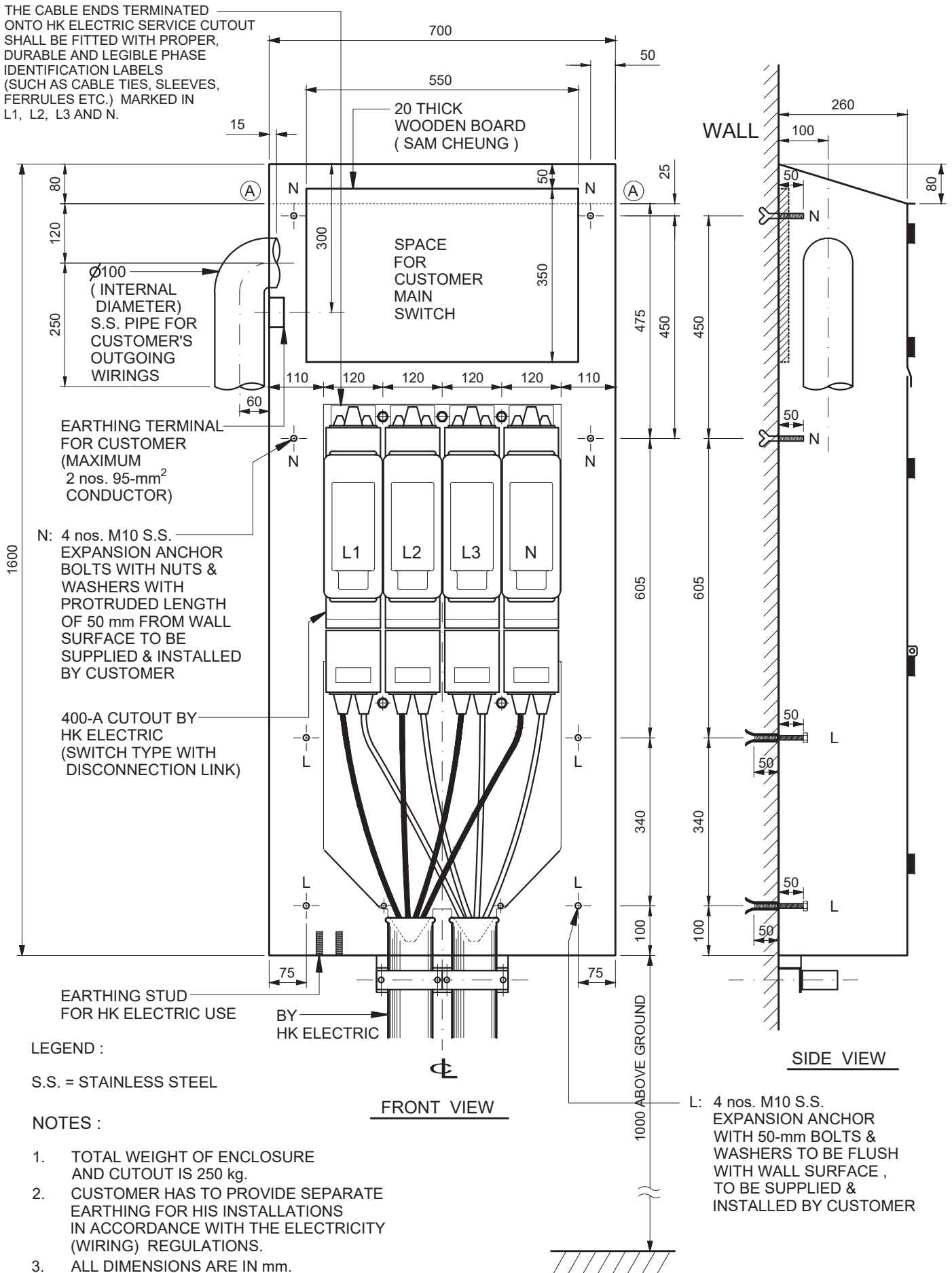

Drg. No. GCS/3/10

SPACE REQUIREMENTS FOR STAINLESS STEEL WEATHER-PROOF ENCLOSURE FOR VILLAGE HOUSE ON LAMMA ISLAND (P72/89/R-8)

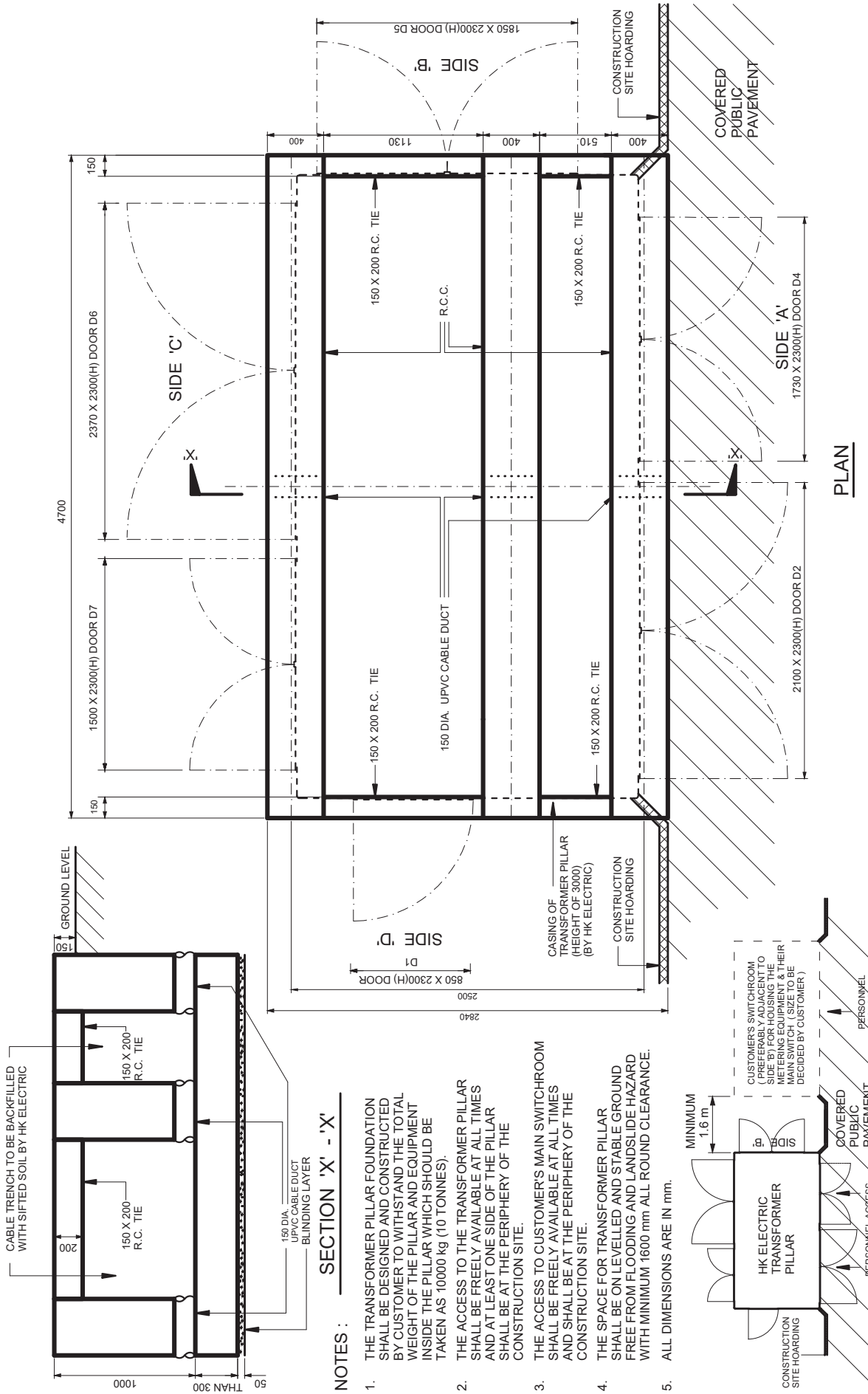

PLAN

LOCATION PLAN

NOTES :

1. THE TRANSFORMER PILLAR FOUNDATION SHALL BE DESIGNED AND CONSTRUCTED BY CUSTOMER TO WITHSTAND THE TOTAL WEIGHT OF THE PILLAR AND EQUIPMENT INSIDE THE PILLAR WHICH SHOULD BE TAKEN AS 10000 kg (10 TONNES).
2. THE ACCESS TO THE TRANSFORMER PILLAR SHALL BE FREELY AVAILABLE AT ALL TIMES AND AT LEAST ONE SIDE OF THE PILLAR SHALL BE AT THE PERIPHERY OF THE CONSTRUCTION SITE.
3. THE ACCESS TO CUSTOMER'S MAIN SWITCHROOM SHALL BE FREELY AVAILABLE AT ALL TIMES AND SHALL BE AT THE PERIPHERY OF THE CONSTRUCTION SITE.
4. THE SPACE FOR TRANSFORMER PILLAR SHALL BE ON LEVELLED AND STABLE GROUND FREE FROM FLOODING AND LANDSLIDE HAZARD WITH MINIMUM 1600 mm ALL ROUND CLEARANCE.
5. ALL DIMENSIONS ARE IN mm.

Dr. No. GCS/3/11
TRANSFORMER PILLAR FOUNDATION
(FOR T.P. IN CONSTRUCTION SITE WITH RTU) (P505/00/R-2)

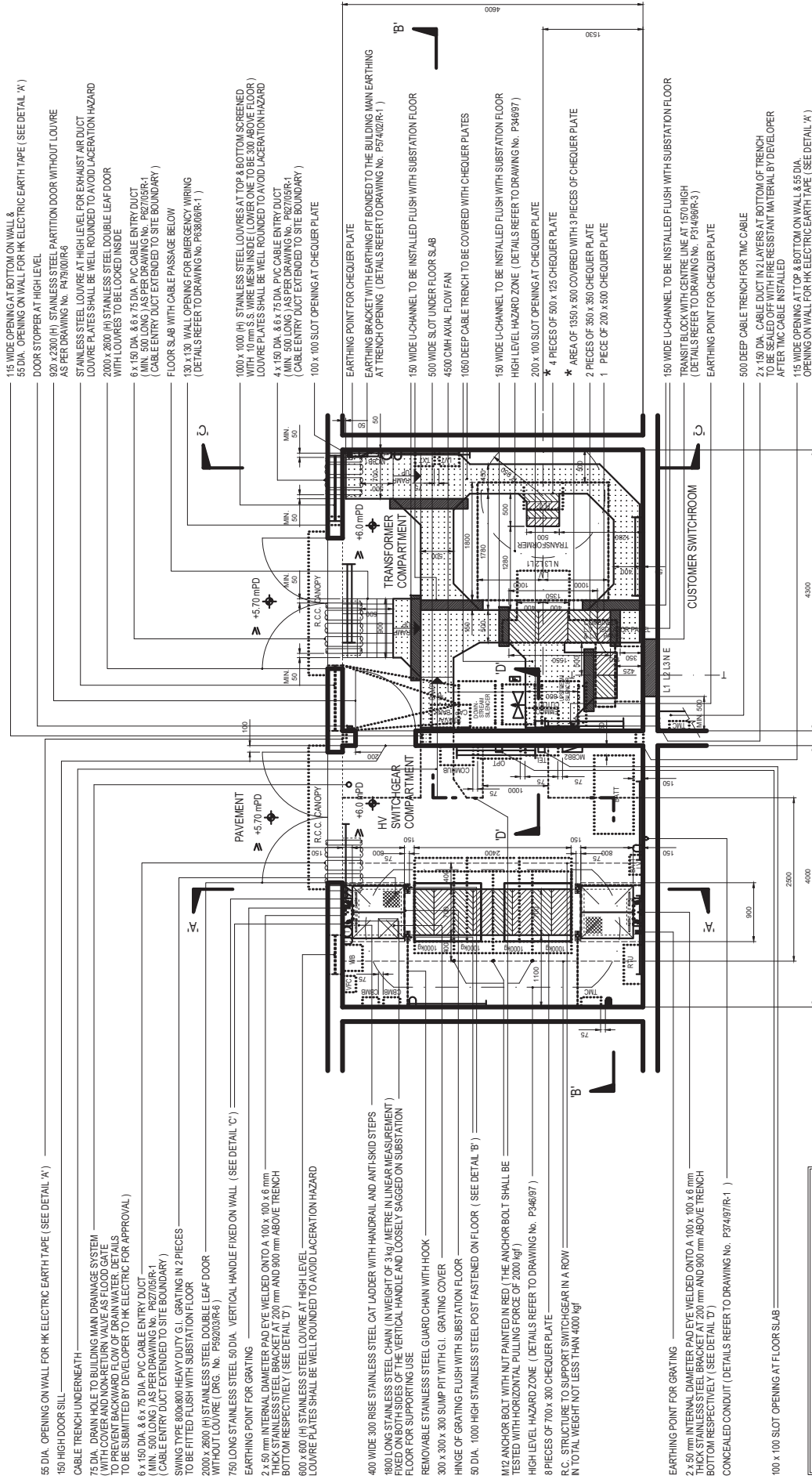

1.15 WIDE OPENING AT BOTTOM ON WALL & 55 DIA. OPENING ON WALL FOR HK ELECTRIC EARTH TAPE (SEE DETAIL 'X')
 DOOR STOPPER AT HIGH LEVEL
 920 x 2300 (H) STAINLESS STEEL PARTITION DOOR WITHOUT LOUVRE AS PER DRAWING No. P479/00/R-6
 STAINLESS STEEL LOUVRE AT HIGH LEVEL FOR EXHAUST AIR DUCT LOUVRE PLATES SHALL BE WELL ROUNDED TO AVOID LACERATION HAZARD WITH LOUVRES TO BE LOCKED INSIDE
 6 x 150 DIA. & 6 x 75 DIA. PVC CABLE ENTRY DUCT (MIN. 500 LONG) AS PER DRAWING No. P627/05/R-1 (CABLE ENTRY DUCT EXTENDED TO SITE BOUNDARY)
 FLOOR SLAB WITH CABLE PASSAGE BELOW
 130 x 130 WALL OPENING FOR EMERGENCY WIRING (DETAILS REFER TO DRAWING No. P638/06/R-1)

1000 x 1000 (H) STAINLESS STEEL LOUVRES AT TOP & BOTTOM SCREENED WITH 10 mm S.S. WIRE MESH INSIDE (LOWER ONE TO BE 300 ABOVE FLOOR) LOUVRE PLATES SHALL BE WELL ROUNDED TO AVOID LACERATION HAZARD
 4 x 150 DIA. & 6 x 75 DIA. PVC CABLE ENTRY DUCT (MIN. 500 LONG) AS PER DRAWING No. P627/05/R-1 (CABLE ENTRY DUCT EXTENDED TO SITE BOUNDARY)
 100 x 100 SLOT OPENING AT CHEQUER PLATE

EARTHING POINT FOR CHEQUER PLATE
 EARTHING BRACKET WITH EARTHING PIT BONDED TO THE BUILDING MAIN EARTHING AT TRENCH OPENING (DETAILS REFER TO DRAWING No. P574/02/R-1)
 150 WIDE U-CHEANNEL TO BE INSTALLED FLUSH WITH SUBSTATION FLOOR
 500 WIDE 3.0T UNDER FLOOR SLAB
 4500 CMH AXIAL FLOW FAN
 1050 DEEP CABLE TRENCH TO BE COVERED WITH CHEQUER PLATES
 150 WIDE U-CHEANNEL TO BE INSTALLED FLUSH WITH SUBSTATION FLOOR HIGH LEVEL HAZARD ZONE (DETAILS REFER TO DRAWING No. P346/97)
 200 x 100 SLOT OPENING AT CHEQUER PLATE
 * 4 PIECES OF 500 x 125 CHEQUER PLATE
 * AREA OF 1500 x 500 COVERED WITH 3 PIECES OF CHEQUER PLATE
 2 PIECES OF 350 x 350 CHEQUER PLATE
 1 PIECE OF 200 x 500 CHEQUER PLATE

150 WIDE U-CHEANNEL TO BE INSTALLED FLUSH WITH SUBSTATION FLOOR TRANSIT BLOCK WITH CENTRE LINE AT 1570 HIGH (DETAILS REFER TO DRAWING No. P314/96/R-3)
 EARTHING POINT FOR CHEQUER PLATE
 500 DEEP CABLE TRENCH FOR TMC CABLE
 2 x 150 DIA. CABLE DUCT IN 2 LAYERS AT BOTTOM OF TRENCH TO BE SEALED OFF WITH FIRE RESISTANT MATERIAL BY DEVELOPER AFTER TMC CABLE INSTALLED
 115 WIDE OPENING AT TOP & BOTTOM ON WALL & 55 DIA. OPENING ON WALL FOR HK ELECTRIC EARTH TAPE (SEE DETAIL 'X')

55 DIA. OPENING ON WALL FOR HK ELECTRIC EARTH TAPE (SEE DETAIL 'X')
 150 HIGH DOOR SKILL
 CABLE TRENCH UNDERNEATH
 75 DIA. DRAIN HOLE TO BUILDING MAIN DRAINAGE SYSTEM (WITH COVER AND NON-RETURN VALVE AS FLOOD GATE TO PREVENT BACKWARD FLOW OF DRAIN WATER. DETAILS TO BE SUBMITTED BY DEVELOPER TO HK ELECTRIC FOR APPROVAL)
 6 x 150 DIA. & 6 x 75 DIA. PVC CABLE ENTRY DUCT (MIN. 500 LONG) AS PER DRAWING No. P627/05/R-1 (CABLE ENTRY DUCT EXTENDED TO SITE BOUNDARY)
 SWING TYPE 800x800 HEAVY DUTY G.I. GRATING IN 2 PIECES TO BE FITTED FLUSH WITH SUBSTATION FLOOR
 2000 x 2000 (H) STAINLESS STEEL DOUBLE LEAF DOOR WITHOUT LOUVRE (DRG. No. P592/03/R-6)
 750 LONG STAINLESS STEEL 50 DIA. VERTICAL HANDLE FIXED ON WALL (SEE DETAIL 'C')
 EARTHING POINT FOR GRATING
 2 x 50 mm INTERNAL DIAMETER PAD EYE WELDED ONTO A 100 x 100 x 6 mm THICK STAINLESS STEEL BRACKET AT 200 mm AND 800 mm ABOVE TRENCH BOTTOM RESPECTIVELY (SEE DETAIL 'D')
 600 x 600 (H) STAINLESS STEEL LOUVRE AT HIGH LEVEL LOUVRE PLATES SHALL BE WELL ROUNDED TO AVOID LACERATION HAZARD

400 WIDE 300 RISE STAINLESS STEEL CAT LADDER WITH HANDRAIL AND ANTI-SKID STEPS
 1800 LONG STAINLESS STEEL CHAIN (IN WEIGHT OF 3 kg/METRE IN LINEAR MEASUREMENT) FIXED ON BOTH SIDES OF THE VERTICAL HANDLE AND LOOSELY SAGGED ON SUBSTATION FLOOR FOR SUPPORTING USE
 REMOVABLE STAINLESS STEEL GUARD CHAIN WITH HOOK
 300 x 300 x 300 SLUMP PITT WITH G.I. GRATING COVER
 HINGE OF GRATING FLUSH WITH SUBSTATION FLOOR
 50 DIA. 1000 HIGH STAINLESS STEEL POST FASTENED ON FLOOR (SEE DETAIL 'B')
 M12 ANCHOR BOLT WITH NUT PAINTED IN RED (THE ANCHOR BOLT SHALL BE TESTED WITH HORIZONTAL PULLING FORCE OF 2000 kgf)
 HIGH LEVEL HAZARD ZONE (DETAILS REFER TO DRAWING No. P346/97)
 R.C. STRUCTURE TO SUPPORT SWITCHGEAR IN A ROW IN TOTAL WEIGHT NOT LESS THAN 4000 kgf

EARTHING POINT FOR GRATING
 2 x 50 mm INTERNAL DIAMETER PAD EYE WELDED ONTO A 100 x 100 x 6 mm THICK STAINLESS STEEL BRACKET AT 200 mm AND 800 mm ABOVE TRENCH BOTTOM RESPECTIVELY (SEE DETAIL 'D')
 CONGEALED CONDUIT (DETAILS REFER TO DRAWING No. P374/97/R-1)
 100 x 100 SLOT OPENING AT FLOOR SLAB

NOTE: WIDTH OF TRENCH SHALL BE THE MEASURED SPACE BETWEEN EDGES OF CHEQUER PLATE AND SUPPORTING ANGLES

OPTION 1
 PLAN OF TRANSFORMER COMPARTMENT & HV SWITCHGEAR COMPARTMENT
 (FOR LEVEL DIFFERENCE BETWEEN SUBSTATION FLOOR AND OUTSIDE PAVEMENT LEVEL \leq 300 mm AND NOT LESS THAN 150 mm.)
 Drg. No. GCS/3/12
 TYPICAL LAYOUT FOR 1 - TX. SUBSTATION WITH HV CABLE PIT
 (P512/00/R-9) SHEET 1 OF 9

DOUBLE-SLAB CEILING CONSTRUCTION AS PER ITEM 1.13 OF DRAWING NO. P.585/03/R-7

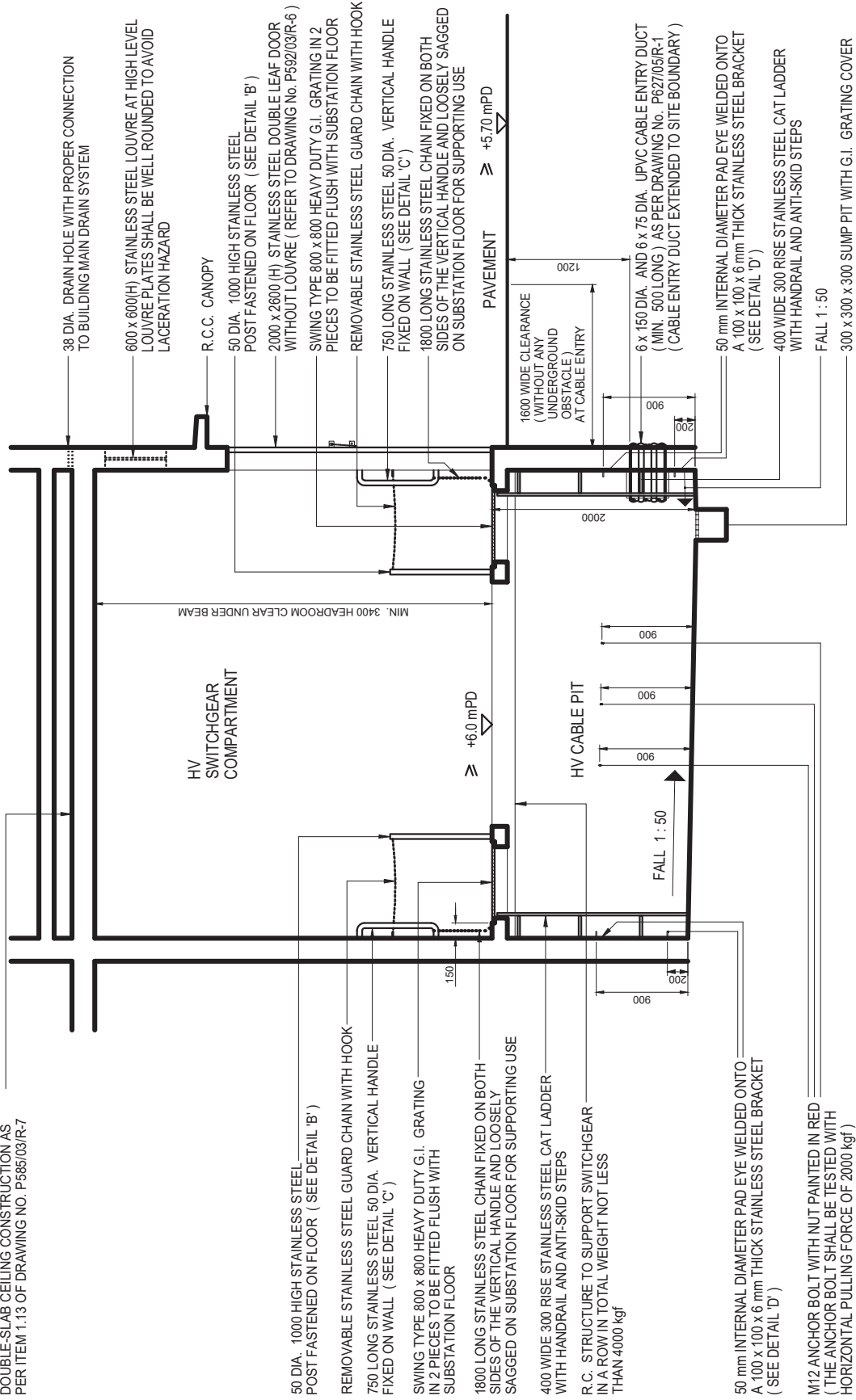

SECTION 'A' - 'A'

NOTE : ALL DIMENSIONS ARE IN mm.

Dr. No. GCS/3/12
TYPICAL LAYOUT FOR 1 - TX. SUBSTATION WITH HV CABLE PIT
(P512/00/R-9) SHEET 2 OF 9

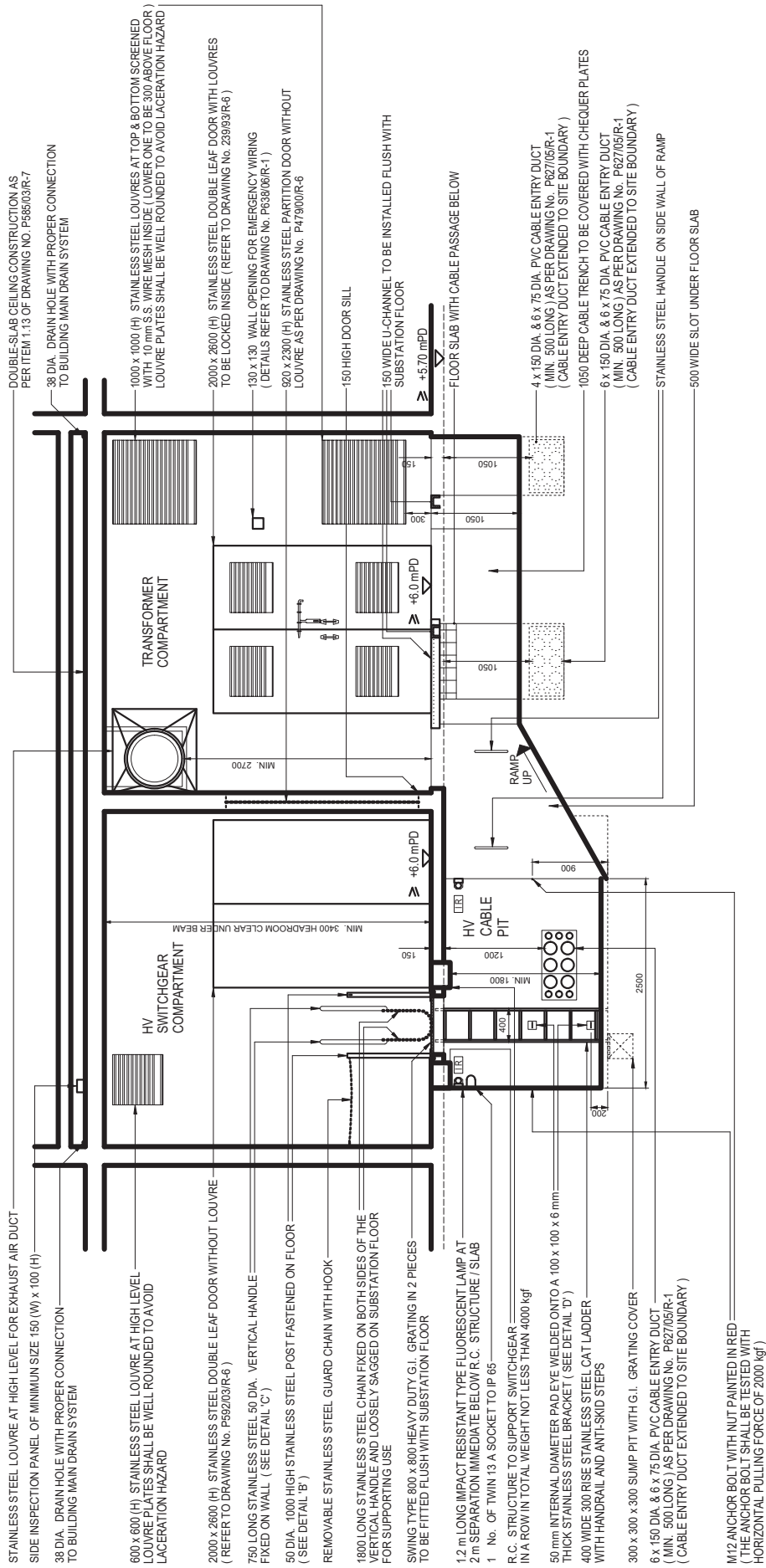

SECTION 'B' - 'B'

NOTE : ALL DIMENSIONS ARE IN mm.

Dr. No. GCS/3/12
TYPICAL LAYOUT FOR 1 - TX. SUBSTATION WITH HV CABLE PIT
(P512/00/R-9) SHEET 3 OF 9

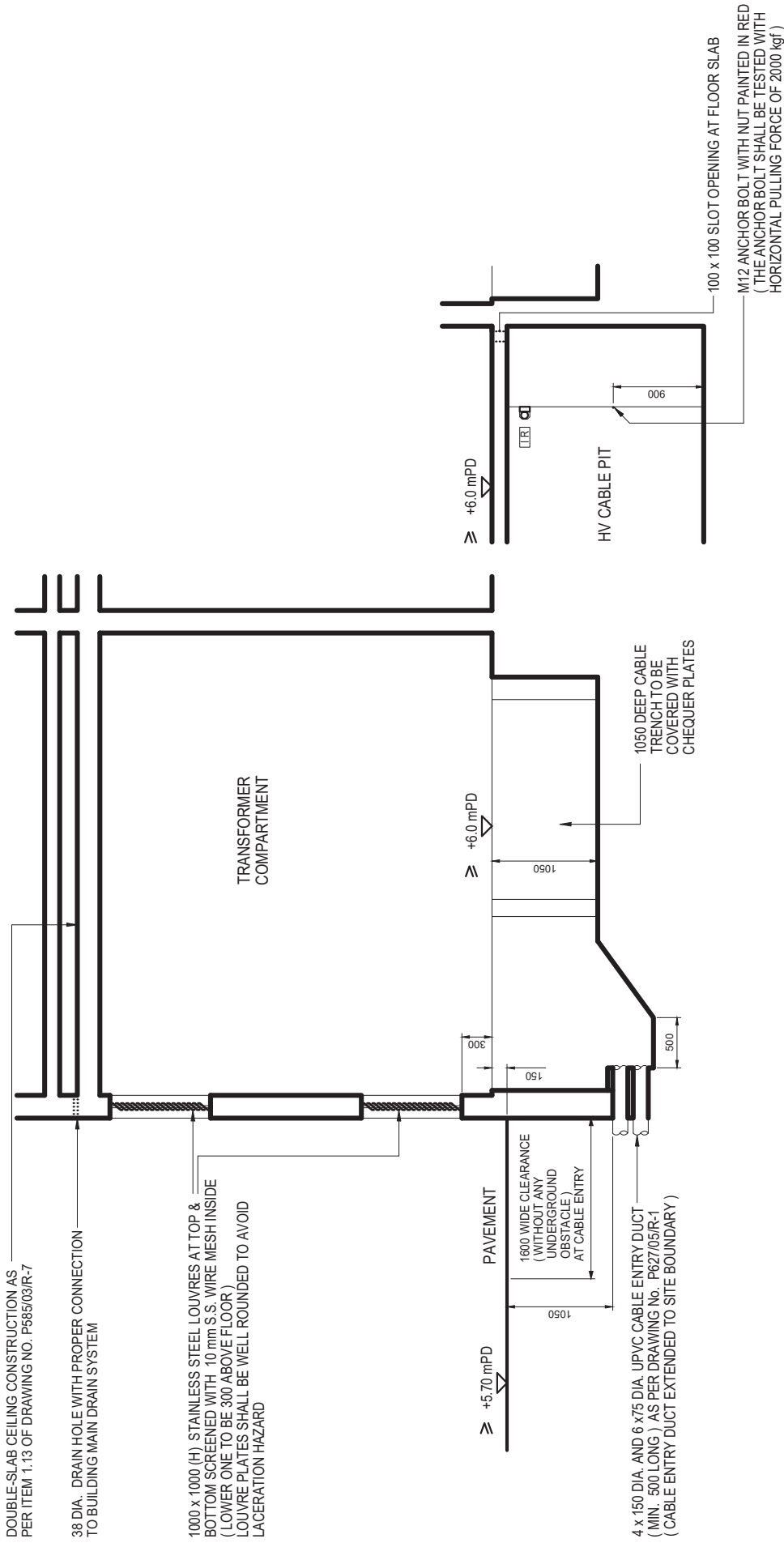

SECTION 'C' - 'C'

SECTION 'D' - 'D'

NOTE : ALL DIMENSIONS ARE IN mm.

Drg. No. GCS/3/12
TYPICAL LAYOUT FOR 1 - TX. SUBSTATION WITH HV CABLE PIT
 (P512/00/R-9) SHEET 4 OF 9

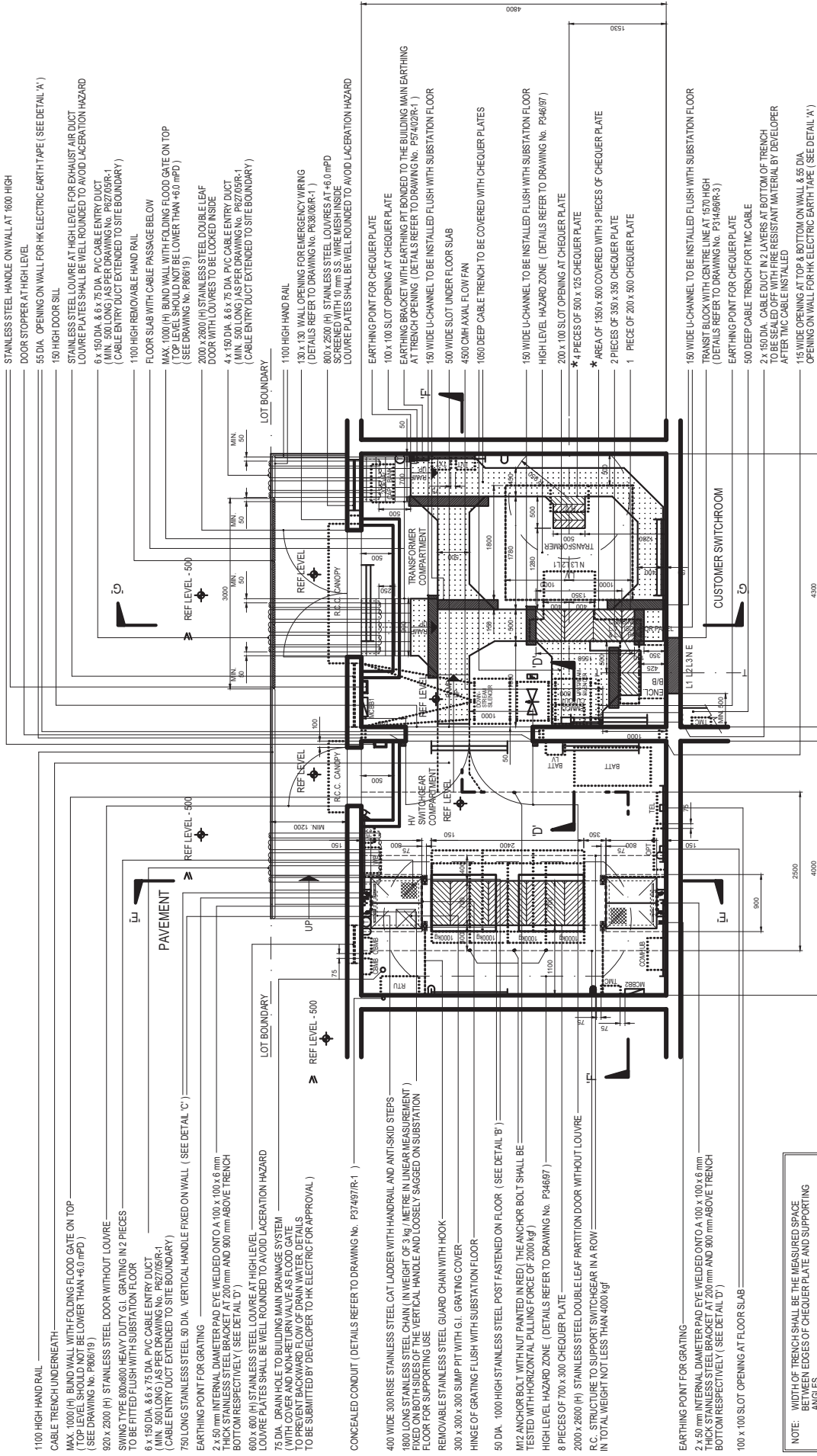

- 1100 HIGH HAND RAIL
- CABLE TRENCH UNDERNEATH
- MAX. 1000 (H) BOND WALL WITH FOLDING FLOOD GATE ON TOP (EVALUATED TO BE LOWER THAN +6.0 mPD) (SEE DRAWING No. P26019)
- 900 x 200 (H) STAINLESS STEEL DOOR WITHOUT LOUVER SWING TYPE 600x800 HEAVY DUTY G.I. GRATING IN 2 PIECES TO BE FITTED FLUSH WITH SUBSTATION FLOOR
- 6 x 150 DIA. & 6 x 75 DIA. PVC CABLE ENTRY DUCT (MIN. 500 LONG) AS PER DRAWING No. P62705R-1 (CABLE ENTRY DUCT EXTENDED TO SITE BOUNDARY)
- 750 LONG STAINLESS STEEL 50 DIA. VERTICAL HANDLE FIXED ON WALL (SEE DETAIL 'C')
- EARTHING POINT FOR GRATING
- 2 x 50 mm INTERNAL DIAMETER PAD EYE WELDED ONTO A 100 x 100 x 6 mm THICK STAINLESS STEEL BRACKET AT 200mm AND 300 mm ABOVE TRENCH BOTTOM RESPECTIVELY (SEE DETAIL 'D')
- 600 x 800 (H) STAINLESS STEEL LOUVER AT HIGH LEVEL LOUVER PLATES SHALL BE WELL ROUNDED TO AVOID LACERATION HAZARD
- 75 DIA. DRAIN HOLE TO BUILDING MAIN DRAINAGE SYSTEM (WITH COVER AND NON-RETURN VALVE AS FLOOD GATE TO PREVENT BACKWARD FLOW OF DRAIN WATER DETAILS TO BE SUBMITTED BY DEVELOPER TO HK ELECTRIC FOR APPROVAL)
- CONCEALED CONDUIT (DETAILS REFER TO DRAWING No. P37497R-1)
- 400 WIDE 300 RISE STAINLESS STEEL CAT LADDER WITH HANDRAIL AND ANTI-SKID STEPS
- 1800 LONG STAINLESS STEEL CHAIN (IN WEIGHT OF 3 kg/METRE IN LINEAR MEASUREMENT) FIXED ON BOTH SIDES OF THE VERTICAL HANDLE AND LOOSELY SAGGED ON SUBSTATION FLOOR FOR SUPPORTING USE
- REMOVABLE STAINLESS STEEL GUARD CHAIN WITH HOOK
- 300 x 300 x 300 SUMP PIT WITH G.I. GRATING COVER
- HINGE OF GRATING FLUSH WITH SUBSTATION FLOOR
- 50 DIA. 1000 HIGH STAINLESS STEEL POST FASTENED ON FLOOR (SEE DETAIL 'B')
- M12 ANCHOR BOLT WITH NUT PAINTED IN RED (THE ANCHOR BOLT SHALL BE TESTED WITH HORIZONTAL PULLING FORCE OF 2000 kgf)
- HIGH LEVEL HAZARD ZONE (DETAILS REFER TO DRAWING No. P34667)
- 8 PIECES OF 700 x 300 CHEQUER PLATE
- 2000 x 2800 (H) STAINLESS STEEL DOUBLE LEAF PARTITION DOOR WITHOUT LOUVER IN TOTAL WEIGHT NOT LESS THAN 4000 kgf
- R.C. STRUCTURE TO SUPPORT SWITCHGEAR IN A ROW
- EARTHING POINT FOR GRATING
- 2 x 50 mm INTERNAL DIAMETER PAD EYE WELDED ONTO A 100 x 100 x 6 mm THICK STAINLESS STEEL BRACKET AT 200mm AND 300 mm ABOVE TRENCH BOTTOM RESPECTIVELY (SEE DETAIL 'D')
- 100 x 100 SLOT OPENING AT FLOOR SLAB

- STAINLESS STEEL HANDLE ON WALL AT 1600 HIGH DOOR STOPPER AT HIGH LEVEL
- 55 DIA. OPENING ON WALL FOR HK ELECTRIC EARTH TAPE (SEE DETAIL 'A')
- 150 HIGH DOOR SILL
- STAINLESS STEEL LOUVER AT HIGH LEVEL FOR EXHAUST AIR DUCT LOUVER PLATES SHALL BE WELL ROUNDED TO AVOID LACERATION HAZARD
- 6 x 150 DIA. & 6 x 75 DIA. PVC CABLE ENTRY DUCT (MIN. 500 LONG) AS PER DRAWING No. P62705R-1 (CABLE ENTRY DUCT EXTENDED TO SITE BOUNDARY)
- 1100 HIGH REMOVABLE HAND RAIL
- FLOOR SLAB WITH CABLE PASSAGE BELOW
- MAX. 1000 (H) BOND WALL WITH FOLDING FLOOD GATE ON TOP (EVALUATED TO BE LOWER THAN +6.0 mPD) (SEE DRAWING No. P26019)
- 2000 x 2800 (H) STAINLESS STEEL DOUBLE LEAF DOOR WITH LOUVER TO BE LOCKED INSIDE
- 4 x 150 DIA. & 6 x 75 DIA. PVC CABLE ENTRY DUCT (MIN. 500 LONG) AS PER DRAWING No. P62705R-1 (CABLE ENTRY DUCT EXTENDED TO SITE BOUNDARY)
- 1100 HIGH HAND RAIL
- 130 x 130 WALL OPENING FOR EMERGENCY WIRING (DETAILS REFER TO DRAWING No. P36106R-1)
- 800 x 2500 (H) STAINLESS STEEL LOUVER AT +6.0 mPD SCREENED WITH 10 mm S.S. WIRE MESH INSIDE LOUVER PLATES SHALL BE WELL ROUNDED TO AVOID LACERATION HAZARD
- EARTHING POINT FOR CHEQUER PLATE
- 100 x 100 SLOT OPENING AT CHEQUER PLATE
- EARTHING BRACKET WITH EARTHING PIT BONDED TO THE BUILDING MAIN EARTHING AT TRENCH OPENING (DETAILS REFER TO DRAWING No. P57402R-1)
- 150 WIDE U-CHEANNEL TO BE INSTALLED FLUSH WITH SUBSTATION FLOOR
- 500 WIDE SLOT UNDER FLOOR SLAB
- 4500 CWX AXIAL FLOW FAN
- 100 DEEP CABLE TRENCH TO BE COVERED WITH CHEQUER PLATES
- 150 WIDE U-CHEANNEL TO BE INSTALLED FLUSH WITH SUBSTATION FLOOR
- HIGH LEVEL HAZARD ZONE (DETAILS REFER TO DRAWING No. P34667)
- 200 x 100 SLOT OPENING AT CHEQUER PLATE
- 8 PIECES OF 500 x 125 CHEQUER PLATE
- AREA OF 1500 x 500 COVERED WITH 3 PIECES OF CHEQUER PLATE
- 2 PIECES OF 350 x 350 CHEQUER PLATE
- 1 PIECE OF 200 x 500 CHEQUER PLATE
- 150 WIDE U-CHEANNEL TO BE INSTALLED FLUSH WITH SUBSTATION FLOOR
- TRANSIT BLOCK WITH CENTRE LINE AT 1570 HIGH (DETAILS REFER TO DRAWING No. P31456R-3)
- EARTHING POINT FOR CHEQUER PLATE
- 500 DEEP CABLE TRENCH FOR TMC CABLE
- 2 x 150 DIA. CABLE DUCT IN 2 LAYERS AT BOTTOM OF TRENCH TO BE SEALED OFF WITH FIRE RESISTANT MATERIAL BY DEVELOPER AFTER TMC CABLE INSTALLED
- 115 WIDE OPENING AT TOP & BOTTOM ON WALL & 55 DIA. OPENING ON WALL FOR HK ELECTRIC EARTH TAPE (SEE DETAIL 'A')

OPTION 2

PLAN OF TRANSFORMER COMPARTMENT & HV SWITCHGEAR COMPARTMENT
(FOR LEVEL DIFFERENCE BETWEEN SUBSTATION FLOOR AND OUTSIDE PAVEMENT > 300 mm.)

Drq. No. GCS/3/12
TYPICAL LAYOUT FOR 1 - TX. SUBSTATION WITH HV CABLE PIT
(P512/00/R-9) SHEET 5 OF 9

NOTE: WIDTH OF TRENCH SHALL BE THE MEASURED SPACE BETWEEN EDGES OF CHEQUER PLATE AND SUPPORTING ANGLES

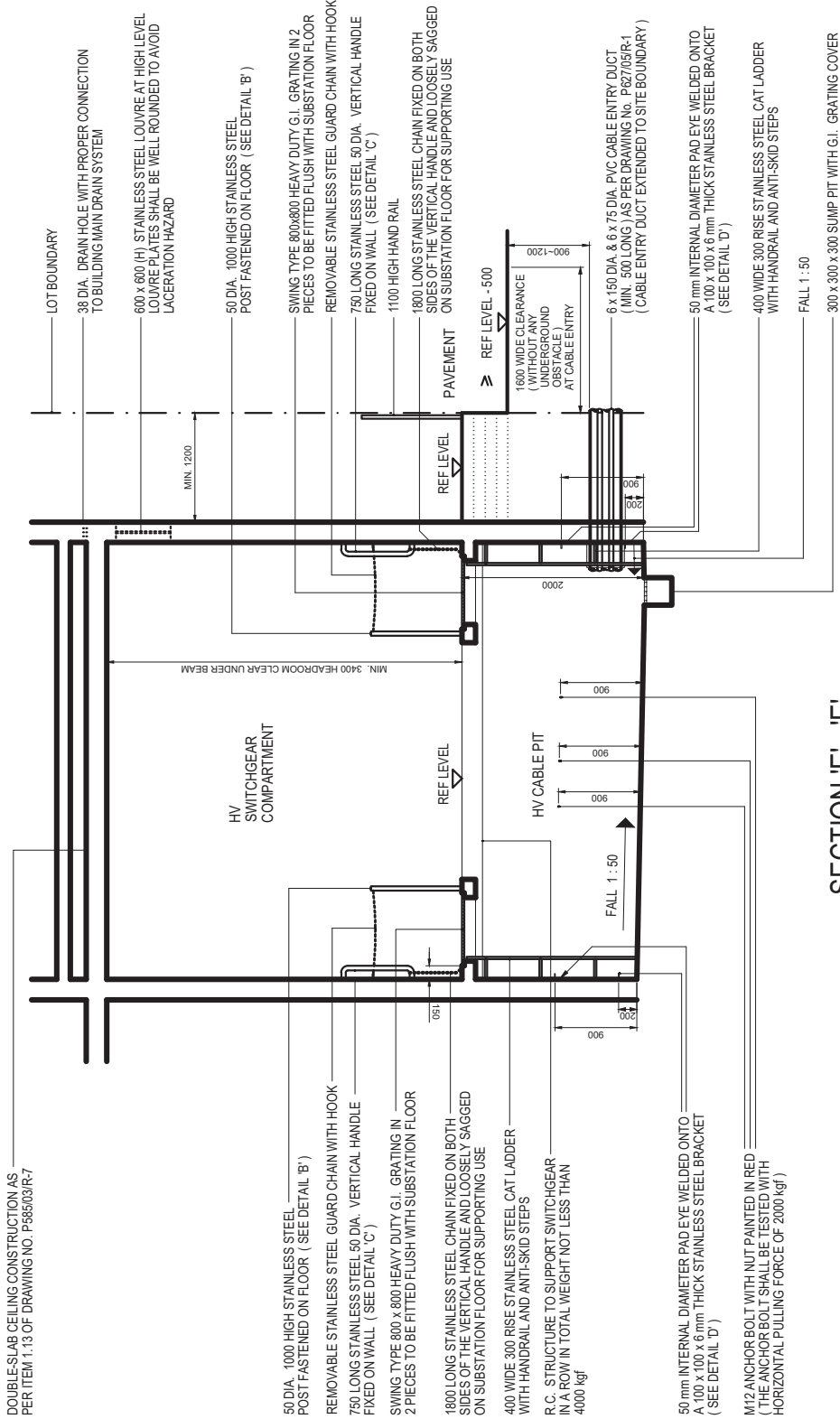

SECTION 'E' - 'E'

NOTE : ALL DIMENSIONS ARE IN mm.

Drg. No. GCS/3/12
TYPICAL LAYOUT FOR 1 - TX. SUBSTATION WITH HV CABLE PIT
(P512/00/R-9) SHEET 6 OF 9

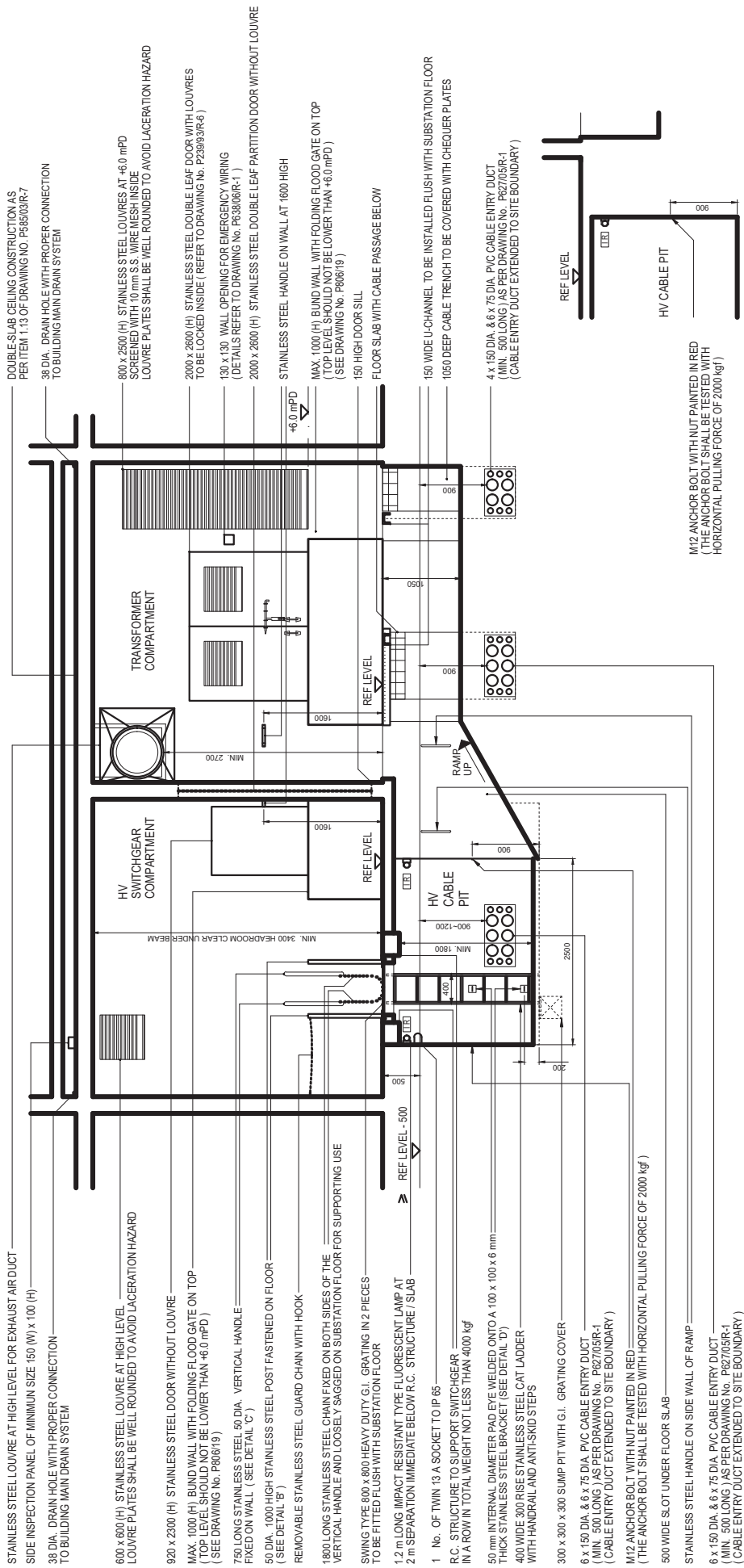

SECTION 'F' - 'F'

SECTION 'D' - 'D'

NOTE : ALL DIMENSIONS ARE IN mm.

Drg. No. GCS/3/12 TYPICAL LAYOUT FOR 1 - TX. SUBSTATION WITH HV CABLE PIT (P512/00/R-9) SHEET 7 OF 9

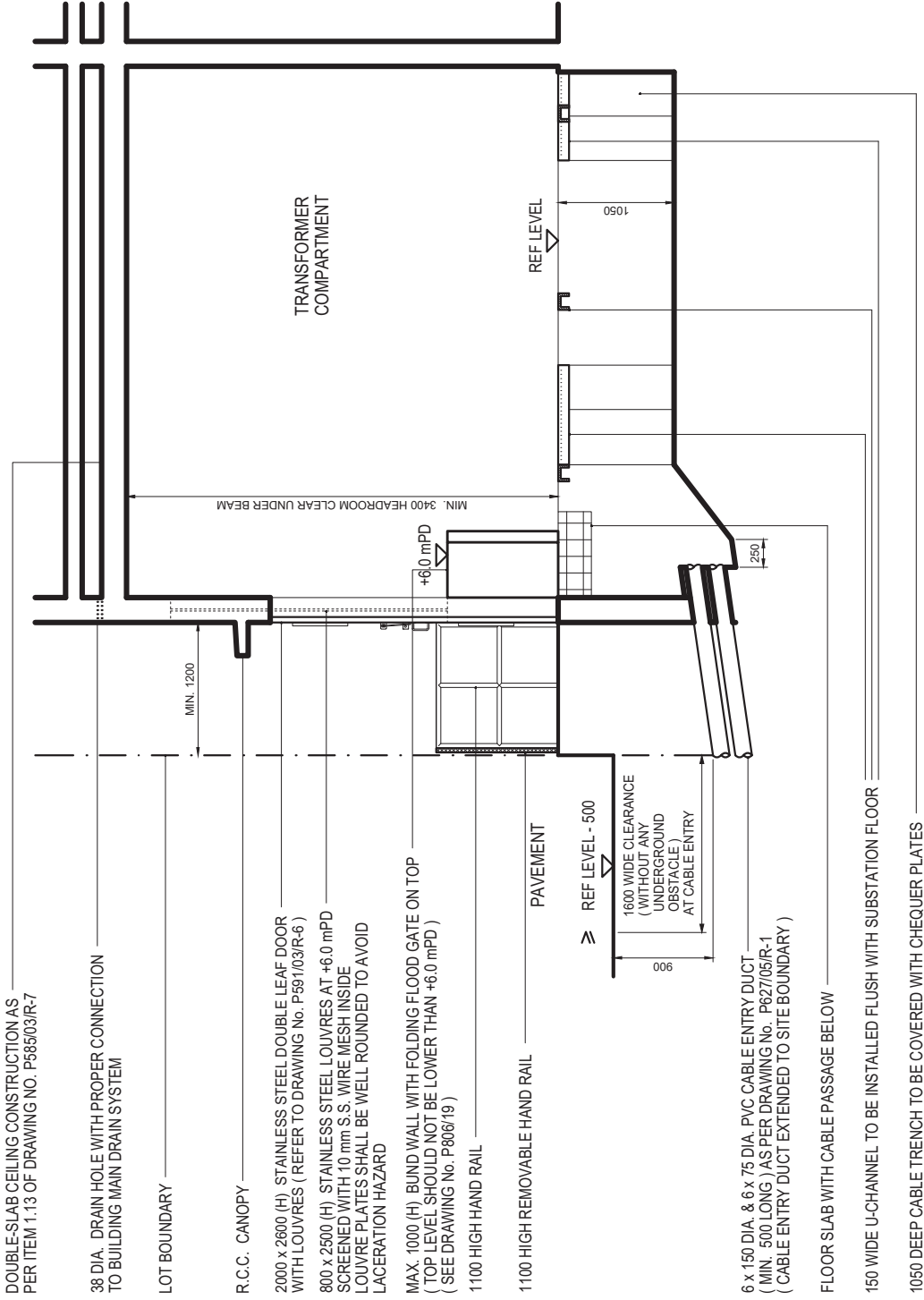

SECTION 'G' - 'G'

NOTE : ALL DIMENSIONS ARE IN mm.

Drg. No. GCS/3/12
TYPICAL LAYOUT FOR 1 - TX. SUBSTATION WITH HV CABLE PIT
(P512/00/R-9) SHEET 8 OF 9

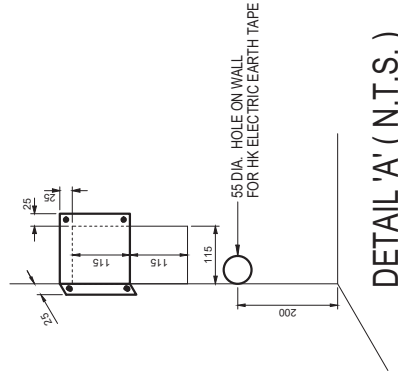

DETAIL 'A' (N.T.S.)

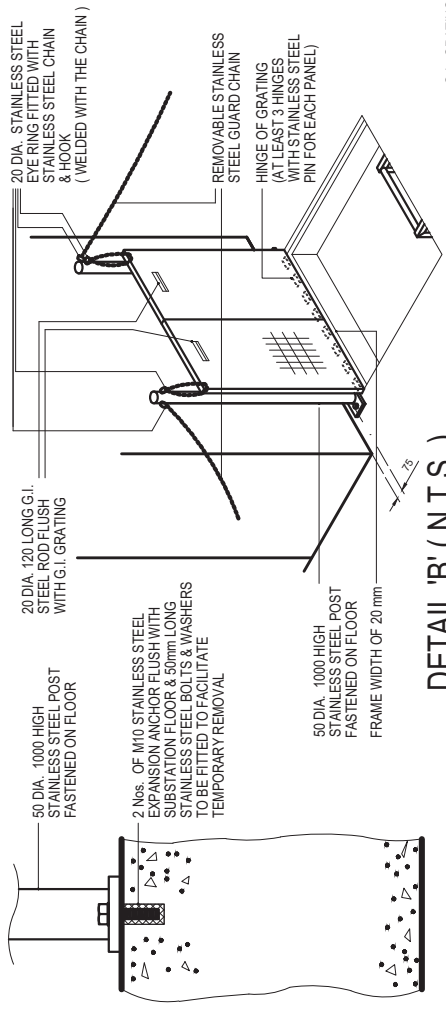

DETAIL 'B' (N.T.S.)

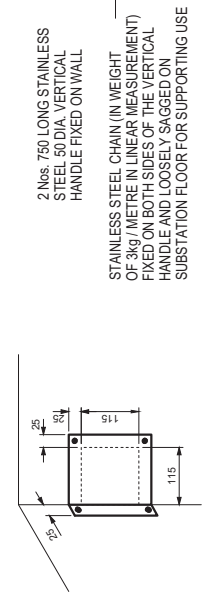

DETAIL 'C' (N.T.S.)

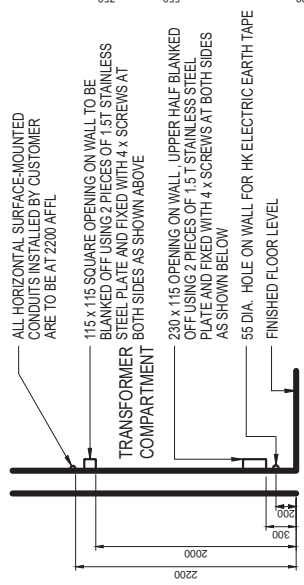

DETAIL 'D' (N.T.S.)

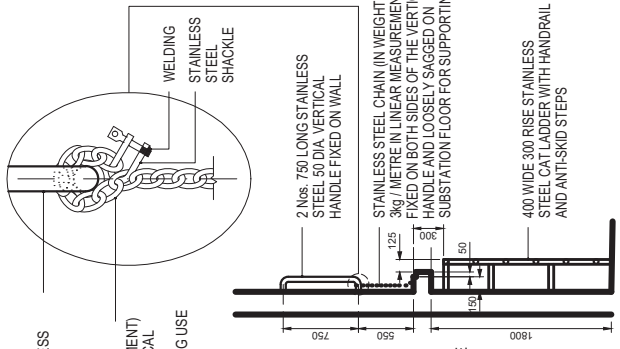

DETAIL 'E' (N.T.S.)

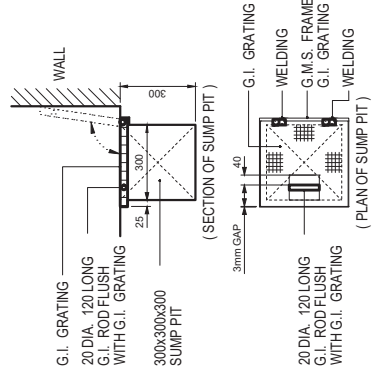

DETAIL 'F' (N.T.S.)

- A. 50 mm INTERNAL DIAMETER PAD EYE WELDED ONTO A 100 x 100 x 6 mm THICK STAINLESS STEEL BRACKET
- B. THE BRACKET SHOULD BE FIXED ON WALL BY 4 NOS. OF M8 EXPANSION ANCHORS AND STAINLESS STEEL BOLTS COMPLETED WITH PLAIN AND SPRING WASHERS
- C. A HORIZONTAL PULLING FORCE IN DIRECTION ALONG THE CENTRE LINE 'D'- 'D' WILL BE APPLIED TO THE PAD EYE. THE PAD EYE SHALL BE SUITABLE FOR A "SAFE WORKING LOAD" OF 2000 kgf. HOWEVER THE "TESTING LOAD" SHALL BE 4000 kgf.

Drp. No. GCS/3/12

TYPICAL LAYOUT FOR 1 - TX. SUBSTATION WITH HV CABLE PIT (P512/00/R-9) SHEET 9 OF 9

NOTE : ALL DIMENSIONS ARE IN mm.

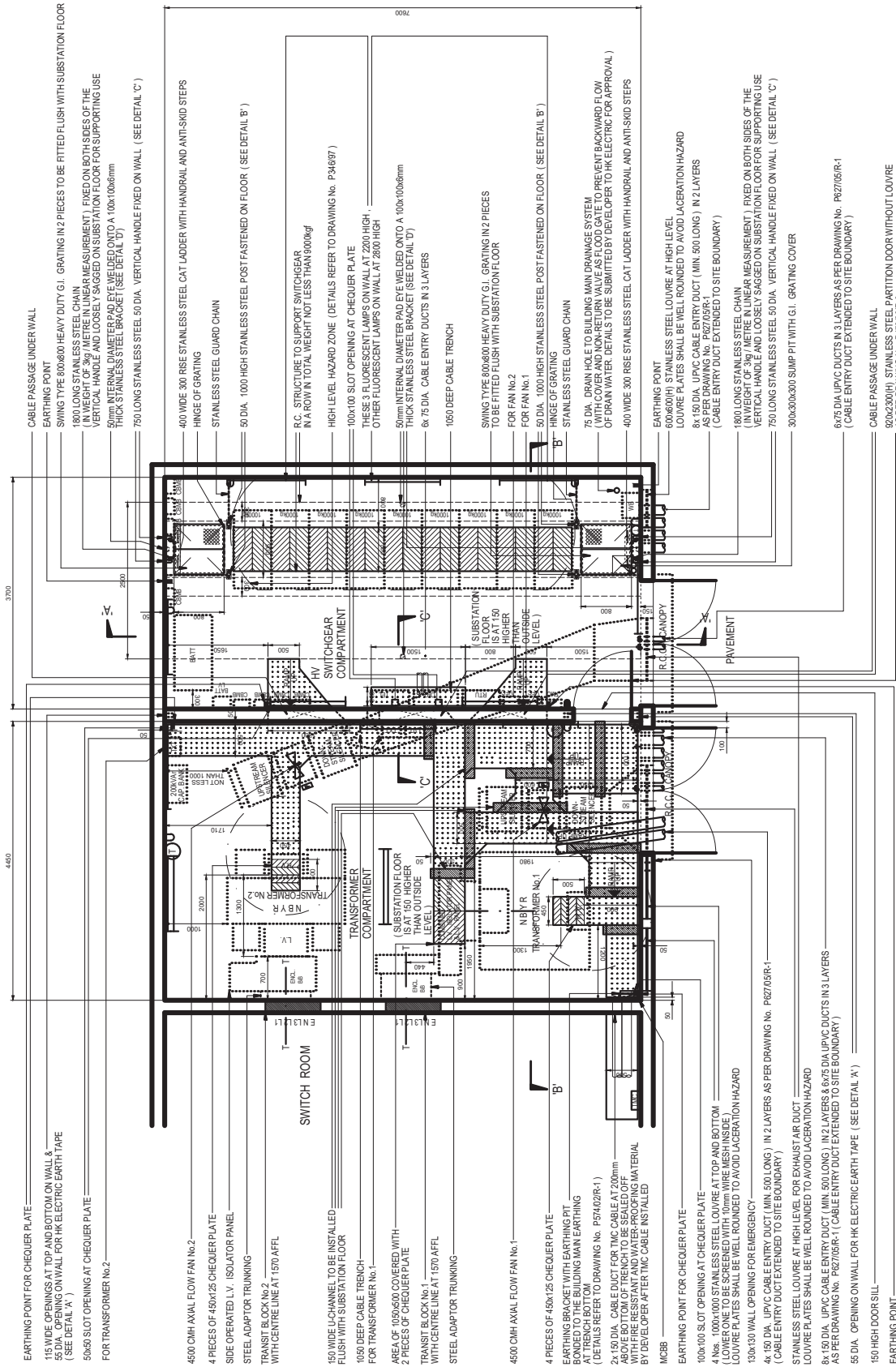

NOTE : ALL DIMENSIONS ARE IN mm.

3.39

PLAN

2000x2800(H) STAINLESS STEEL DOUBLE LEAF DOOR WITH LOUVERES (DRG. No. P59103R-6)

2000x2800(H) STAINLESS STEEL DOUBLE LEAF DOOR WITHOUT LOUVER (DRG. No. P59203R-6)

4660

3730

DRG. No. GCS/3/13

TYPICAL LAYOUT FOR TWIN TRANSFORMER SUBSTATION WITH HV CABLE

PIT (P584/03/R-3) SHEET 1 OF 4

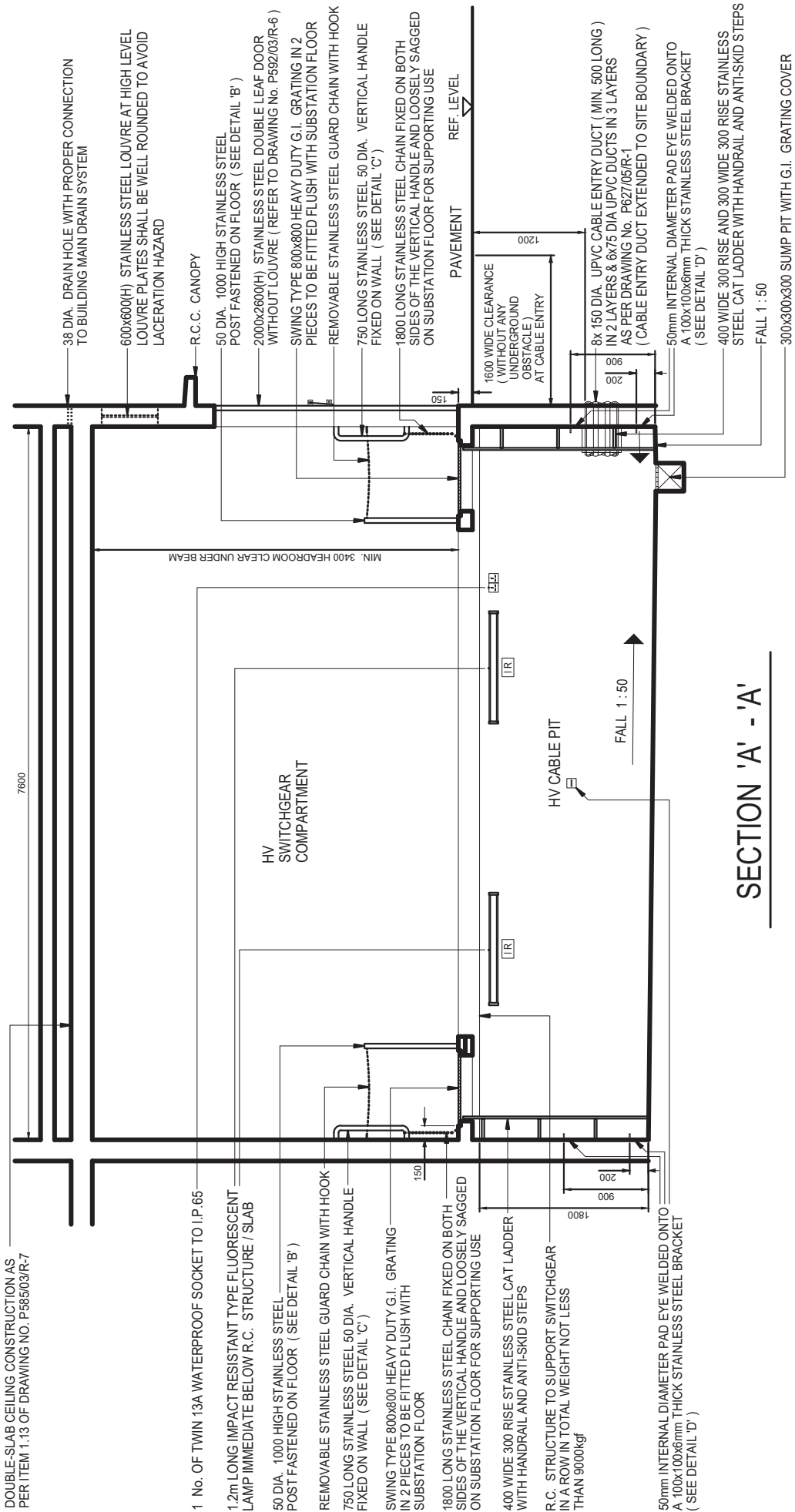

NOTE : ALL DIMENSIONS ARE IN mm.

3.40

Dr. No. GCS/3/13
TYPICAL LAYOUT FOR TWIN TRANSFORMER SUBSTATION WITH HV CABLE
PIT (P584/03/R-3) SHEET 2 OF 4

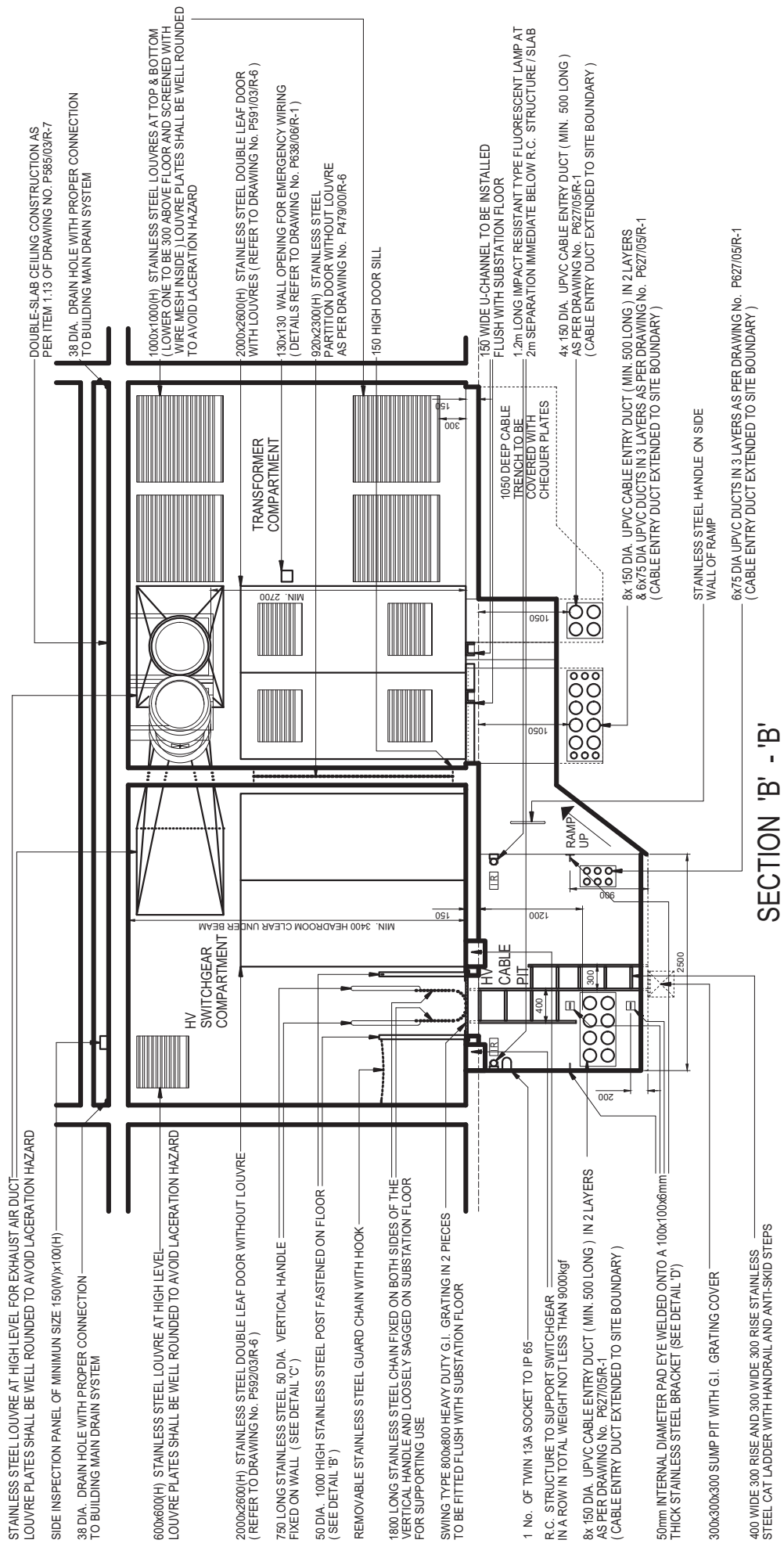

STAINLESS STEEL LOUVRE AT HIGH LEVEL FOR EXHAUST AIR DUCT - LOUVRE PLATES SHALL BE WELL ROUNDED TO AVOID LACERATION HAZARD

SIDE INSPECTION PANEL OF MINIMUM SIZE 150(W)x100(H)

38 DIA. DRAIN HOLE WITH PROPER CONNECTION TO BUILDING MAIN DRAIN SYSTEM

600x600(H) STAINLESS STEEL LOUVRE AT HIGH LEVEL - LOUVRE PLATES SHALL BE WELL ROUNDED TO AVOID LACERATION HAZARD

2000x2600(H) STAINLESS STEEL DOUBLE LEAF DOOR WITHOUT LOUVRE (REFER TO DRAWING No. P59203/R-6)

750 LONG STAINLESS STEEL 50 DIA. VERTICAL HANDLE FIXED ON WALL (SEE DETAIL 'C')

50 DIA. 1000 HIGH STAINLESS STEEL POST FASTENED ON FLOOR (SEE DETAIL 'B')

REMOVABLE STAINLESS STEEL GUARD CHAIN WITH HOOK

1800 LONG STAINLESS STEEL CHAIN FIXED ON BOTH SIDES OF THE VERTICAL HANDLE AND LOOSELY SAGGED ON SUBSTATION FLOOR FOR SUPPORTING USE

SWING TYPE 800x800 HEAVY DUTY G.I. GRATING IN 2 PIECES TO BE FITTED FLUSH WITH SUBSTATION FLOOR

1 No. OF TWIN 13A SOCKET TO IP 65 R.C. STRUCTURE TO SUPPORT SWITCHGEAR IN A ROW IN TOTAL WEIGHT NOT LESS THAN 9000kgf

8x 150 DIA. UPVC CABLE ENTRY DUCT (MIN. 500 LONG) IN 2 LAYERS AS PER DRAWING No. P627/05R-1 (CABLE ENTRY DUCT EXTENDED TO SITE BOUNDARY)

50mm INTERNAL DIAMETER PAD EYE WELDED ONTO A 100x100x6mm THICK STAINLESS STEEL BRACKET (SEE DETAIL 'D')

300x300x300 SUMP PIT WITH G.I. GRATING COVER

400 WIDE 300 RISE AND 300 WIDE 300 RISE STAINLESS STEEL CAT LADDER WITH HANDRAIL AND ANTI-SKID STEPS

DOUBLE SLAB CEILING CONSTRUCTION AS PER ITEM 1.13 OF DRAWING NO. P585/03/R-7

38 DIA. DRAIN HOLE WITH PROPER CONNECTION TO BUILDING MAIN DRAIN SYSTEM

1000x1000(H) STAINLESS STEEL LOUVRES AT TOP & BOTTOM (LOWER ONE TO BE 300 ABOVE FLOOR AND SCREENED WITH WIRE MESH INSIDE) LOUVRE PLATES SHALL BE WELL ROUNDED TO AVOID LACERATION HAZARD

2000x2600(H) STAINLESS STEEL DOUBLE LEAF DOOR WITH LOUVRES (REFER TO DRAWING No. P591/03/R-6)

130x130 WALL OPENING FOR EMERGENCY WIRING (DETAILS REFER TO DRAWING No. P638/06/R-1)

920x2300(H) STAINLESS STEEL PARTITION DOOR WITHOUT LOUVRE AS PER DRAWING No. P479/00/R-6

150 HIGH DOOR SILL

150 WIDE U-CHEMEL TO BE INSTALLED FLUSH WITH SUBSTATION FLOOR

1.2m LONG IMPACT RESISTANT TYPE FLUORESCENT LAMP AT 2m SEPARATION IMMEDIATE BELOW R.C. STRUCTURE / SLAB

4x 150 DIA. UPVC CABLE ENTRY DUCT (MIN. 500 LONG) AS PER DRAWING No. P627/05R-1 (CABLE ENTRY DUCT EXTENDED TO SITE BOUNDARY)

8x 150 DIA. UPVC CABLE ENTRY DUCT (MIN. 500 LONG) IN 2 LAYERS & 6x75 DIA UPVC DUCTS IN 3 LAYERS AS PER DRAWING No. P627/05R-1 (CABLE ENTRY DUCT EXTENDED TO SITE BOUNDARY)

STAINLESS STEEL HANDLE ON SIDE WALL OF RAMP

6x75 DIA UPVC DUCTS IN 3 LAYERS AS PER DRAWING No. P627/05R-1 (CABLE ENTRY DUCT EXTENDED TO SITE BOUNDARY)

SECTION 'B' - 'B'

NOTE : ALL DIMENSIONS ARE IN mm.

Drp. No. GCS/3/13
TYPICAL LAYOUT FOR TWIN TRANSFORMER SUBSTATION WITH HV CABLE PIT (P584/03/R-3) SHEET 3 OF 4

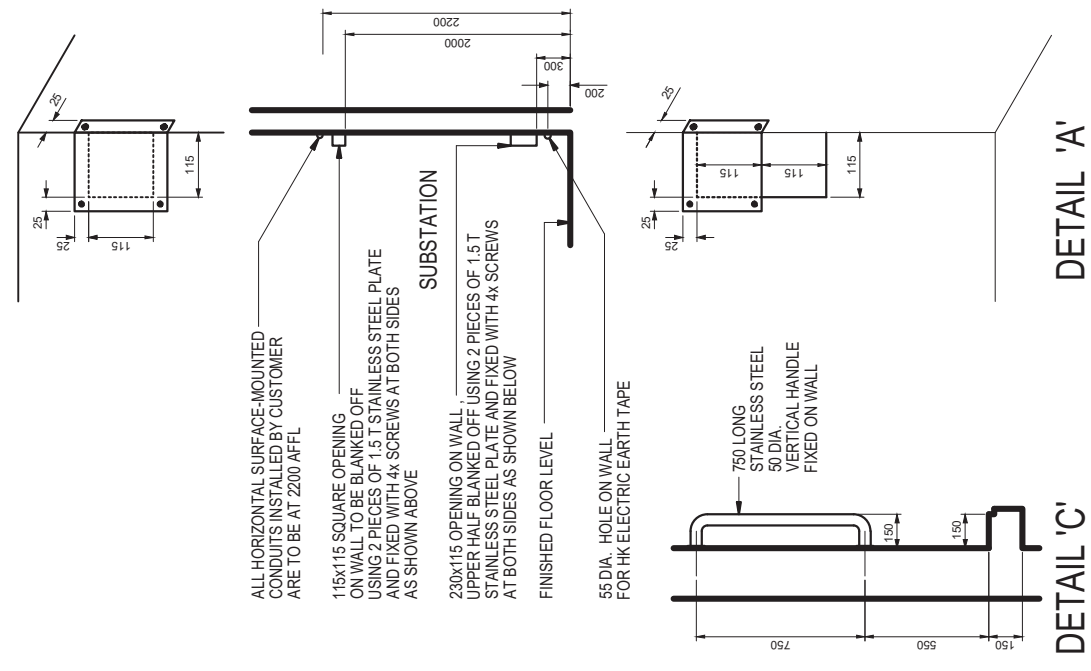

DETAIL 'C'

DETAIL 'A'

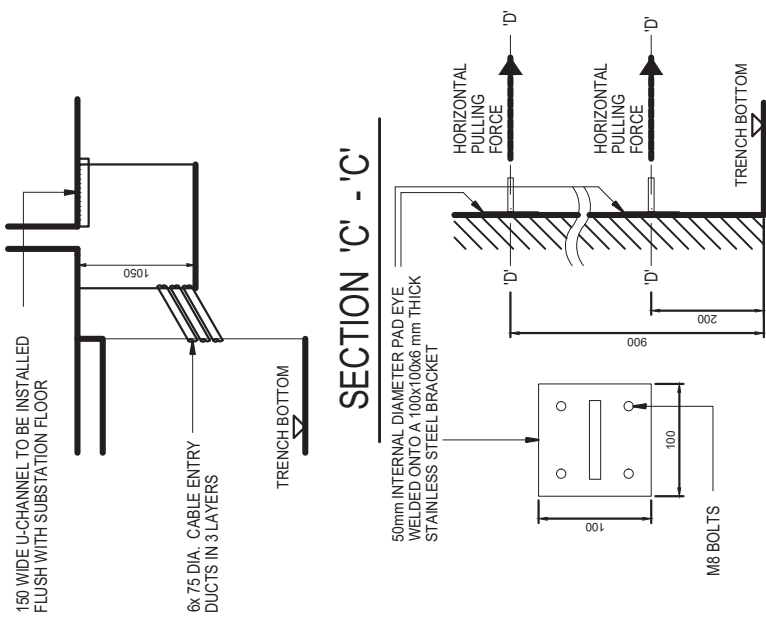

DETAIL 'D'

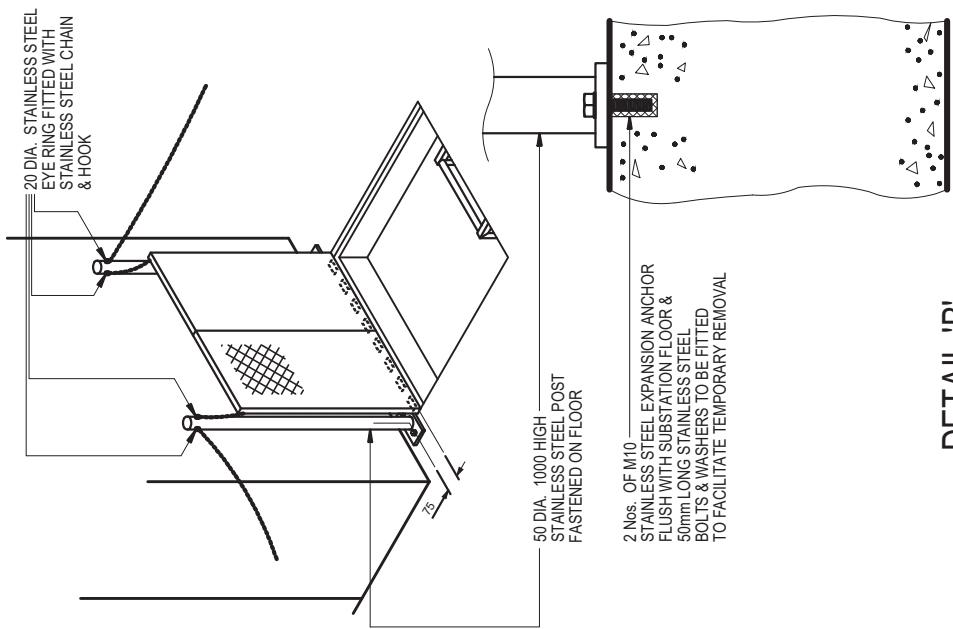

DETAIL 'B'

NOTE : ALL DIMENSIONS ARE IN mm.

Drq. No. GCS/3/13
TYPICAL LAYOUT FOR TWIN TRANSFORMER SUBSTATION WITH HV CABLE
PIT (P584/03/R-3) SHEET 4 OF 4

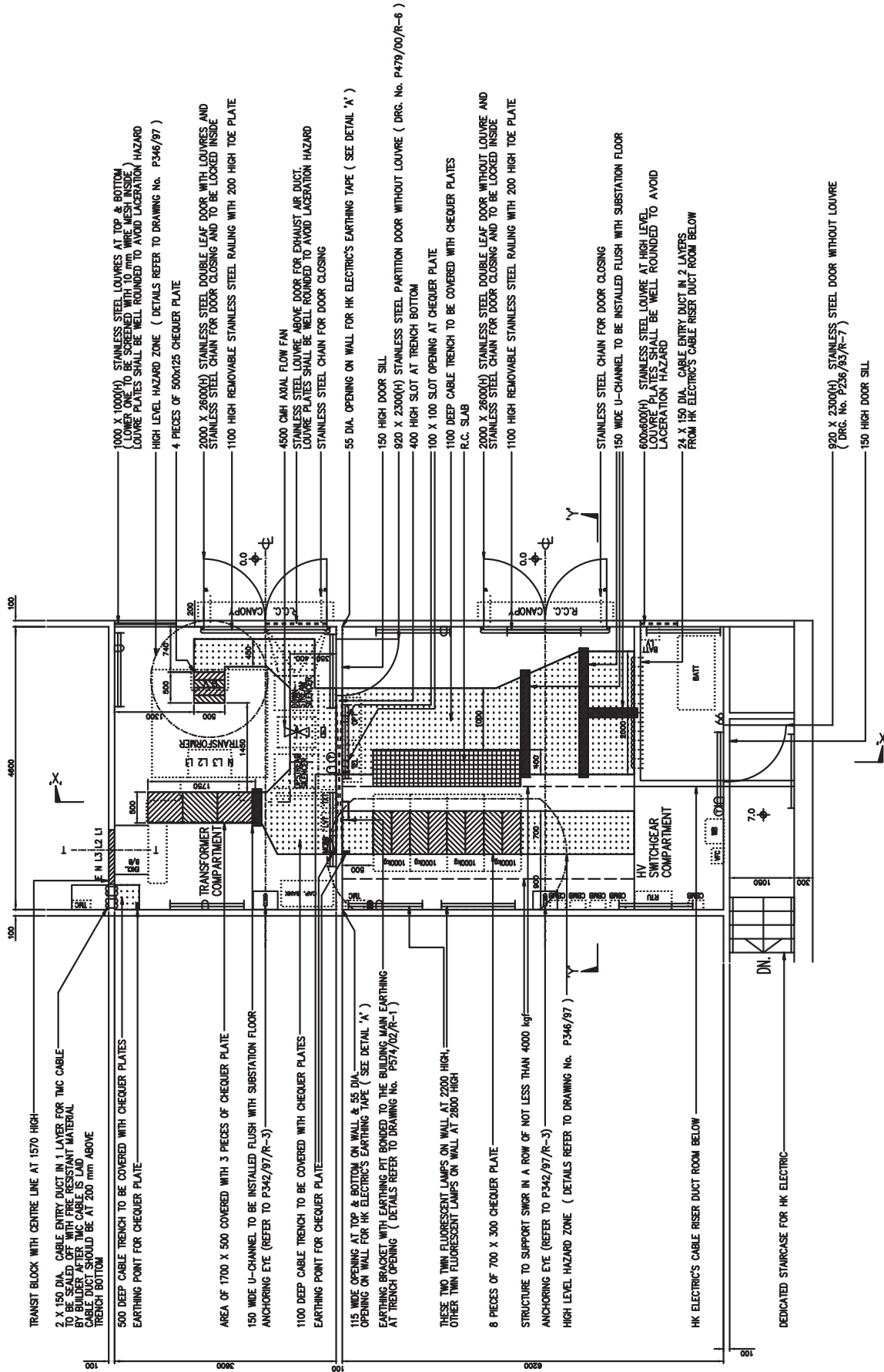

PLAN OF FIRST LEVEL SUBSTATION

Drng. No. GCS/3/14

TYPICAL LAYOUT FOR SINGLE TRANSFORMER FIRST LEVEL SUBSTATION
WITH HV & LV COMPARTMENTS (P381/98/R-6) SHEET 1 OF 6

NOTE : ALL DIMENSIONS ARE IN mm.

- 100 X 100(H) STAINLESS STEEL LOUVRES AT TOP & BOTTOM (LOUVER SHALL BE WELDED TO WALL WITH ANCHORING BOLTS) LOUVER PLATES SHALL BE WELL ROUNDED TO AVOID LACERATION HAZARD
- HIGH LEVEL HAZARD ZONE (DETAILS REFER TO DRAWING No. P346/97)
- 4 PIECES OF 500X125 CHEQUER PLATE
- 2000 X 2600(H) STAINLESS STEEL DOUBLE LEAF DOOR WITH LOUVRES AND STAINLESS STEEL CHAIN FOR DOOR CLOSING AND TO BE LOCKED INSIDE
- 1100 HIGH REMOVABLE STAINLESS STEEL RAILING WITH 200 HIGH TOE PLATE
- 4500 CMH AXIAL FLOW FAN
- STAINLESS STEEL LOUVER ABOVE DOOR FOR EXHAUST AIR DUCT
- LOUVER PLATES SHALL BE WELL ROUNDED TO AVOID LACERATION HAZARD
- STAINLESS STEEL CHAIN FOR DOOR CLOSING
- 55 DIA. OPENING ON WALL FOR HK ELECTRIC'S EARTHING TAPE (SEE DETAIL 'A')
- 150 HIGH DOOR SILL
- 920 X 2300(H) STAINLESS STEEL PARTITION DOOR WITHOUT LOUVER (DRG. No. P479/00/R-6)
- 400 HIGH SLOT AT TRENCH BOTTOM
- 100 X 100 SLOT OPENING AT CHEQUER PLATE
- 1100 DEEP CABLE TRENCH TO BE COVERED WITH CHEQUER PLATES
- R.C. SLAB
- 2000 X 2600(H) STAINLESS STEEL DOUBLE LEAF DOOR WITHOUT LOUVER AND STAINLESS STEEL CHAIN FOR DOOR CLOSING AND TO BE LOCKED INSIDE
- 1100 HIGH REMOVABLE STAINLESS STEEL RAILING WITH 200 HIGH TOE PLATE
- STAINLESS STEEL CHAIN FOR DOOR CLOSING
- 150 WIDE U-CHANNEL TO BE INSTALLED FLUSH WITH SUBSTATION FLOOR
- 600X600(H) STAINLESS STEEL LOUVER AT HIGH LEVEL LOUVER PLATES SHALL BE WELL ROUNDED TO AVOID LACERATION HAZARD
- 24 X 150 DIA. CABLE ENTRY DUCT IN 2 LAYERS FROM HK ELECTRIC'S CABLE RISER DUCT ROOM BELOW
- 920 X 2300(H) STAINLESS STEEL DOOR WITHOUT LOUVER (DRG. No. P256/93/R-7)
- 150 HIGH DOOR SILL

- TRANSIT BLOCK WITH CENTRE LINE AT 1570 HIGH
- 2 X 150 DIA. CABLE ENTRY DUCT IN 1 LAYER FOR TMC CABLE TO BE SEALED OFF WITH FIRE RESISTANT MATERIAL CABLE ENTRY DUCT SHALL BE LAD WITH 200mm ABOVE TRENCH BOTTOM
- 500 DEEP CABLE TRENCH TO BE COVERED WITH CHEQUER PLATES
- EARTHING POINT FOR CHEQUER PLATE
- AREA OF 1700 X 500 COVERED WITH 3 PIECES OF CHEQUER PLATE
- 150 WIDE U-CHANNEL TO BE INSTALLED FLUSH WITH SUBSTATION FLOOR ANCHORING EYE (REFER TO P342/97/R-3)
- 1100 DEEP CABLE TRENCH TO BE COVERED WITH CHEQUER PLATES
- EARTHING POINT FOR CHEQUER PLATE
- 115 WIDE OPENING AT TOP & BOTTOM ON WALL & 55 DIA. OPENING ON WALL FOR HK ELECTRIC'S EARTHING TAPE (SEE DETAIL 'A')
- EARTHING BRACKET WITH EARTHING PIT BONDED TO THE BUILDING MAIN EARTHING AT TRENCH OPENING (DETAILS REFER TO DRAWING No. P574/02/R-1)
- THESE TWO TWIN FLUORESCENT LAMPS ON WALL AT 2200 HIGH. OTHER TWO FLUORESCENT LAMPS ON WALL AT 2800 HIGH
- 8 PIECES OF 700 X 300 CHEQUER PLATE
- STRUCTURE TO SUPPORT SWGR IN A ROW OF NOT LESS THAN 4000 kg
- ANCHORING EYE (REFER TO P342/97/R-3)
- HIGH LEVEL HAZARD ZONE (DETAILS REFER TO DRAWING No. P346/97)
- HK ELECTRIC'S CABLE RISER DUCT ROOM BELOW
- DEDICATED STAIRCASE FOR HK ELECTRIC

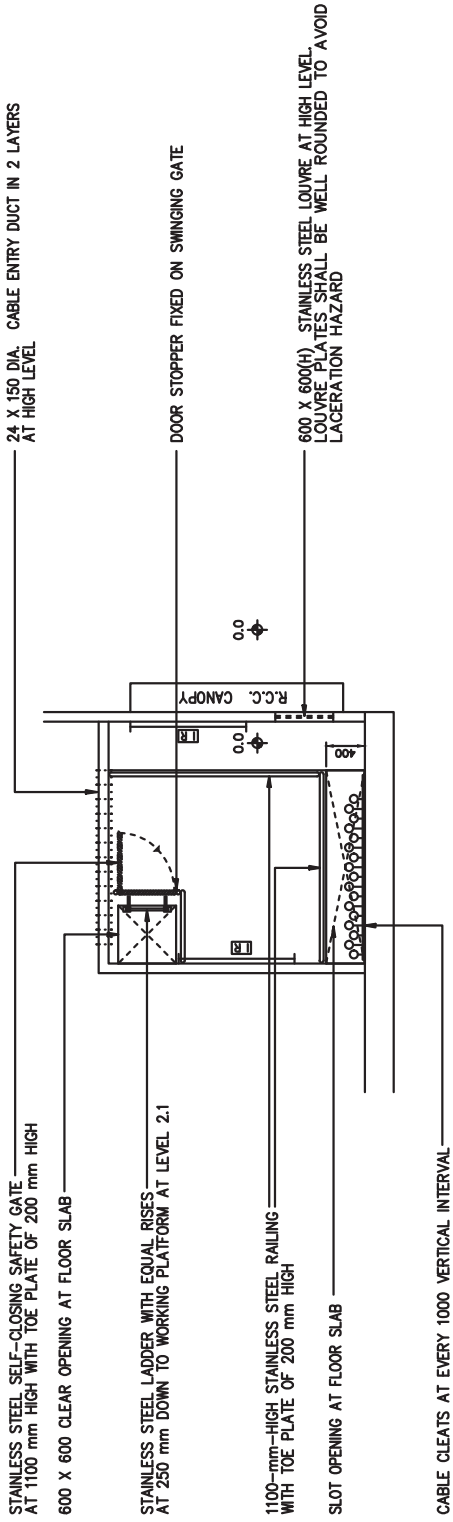

PLAN OF WORKING PLATFORM AT LEVEL 4.3

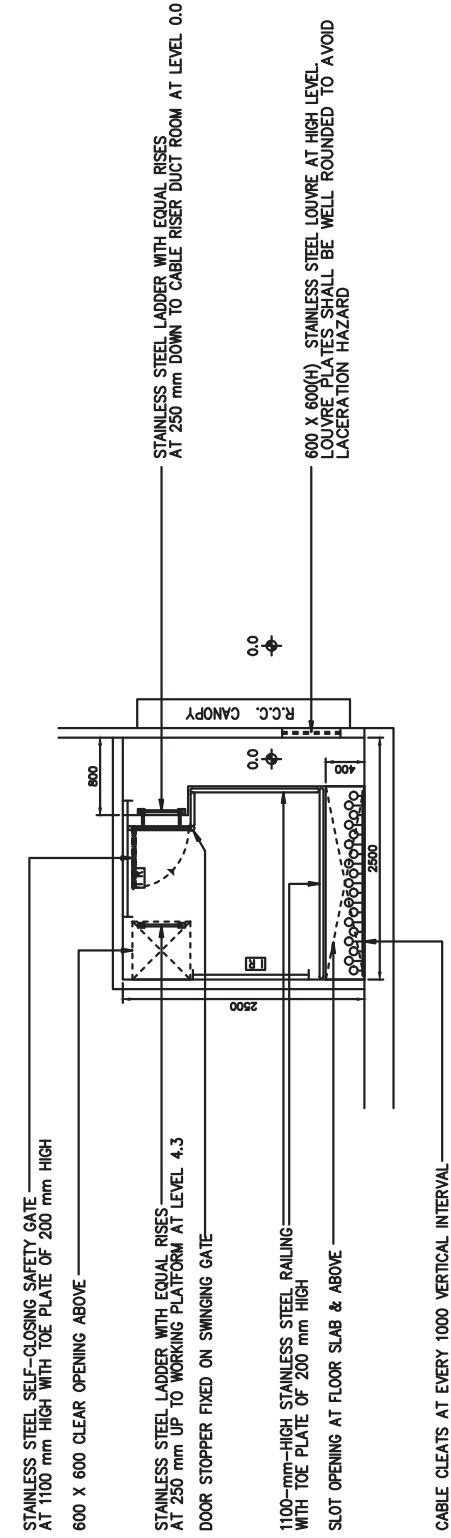

PLAN OF WORKING PLATFORM AT LEVEL 2.1

NOTE : ALL DIMENSIONS ARE IN mm.

Drp. No. GCS/3/14

TYPICAL LAYOUT FOR SINGLE TRANSFORMER FIRST LEVEL SUBSTATION
WITH HV & LV COMPARTMENTS (P381/98/R-6) SHEET 2 OF 6

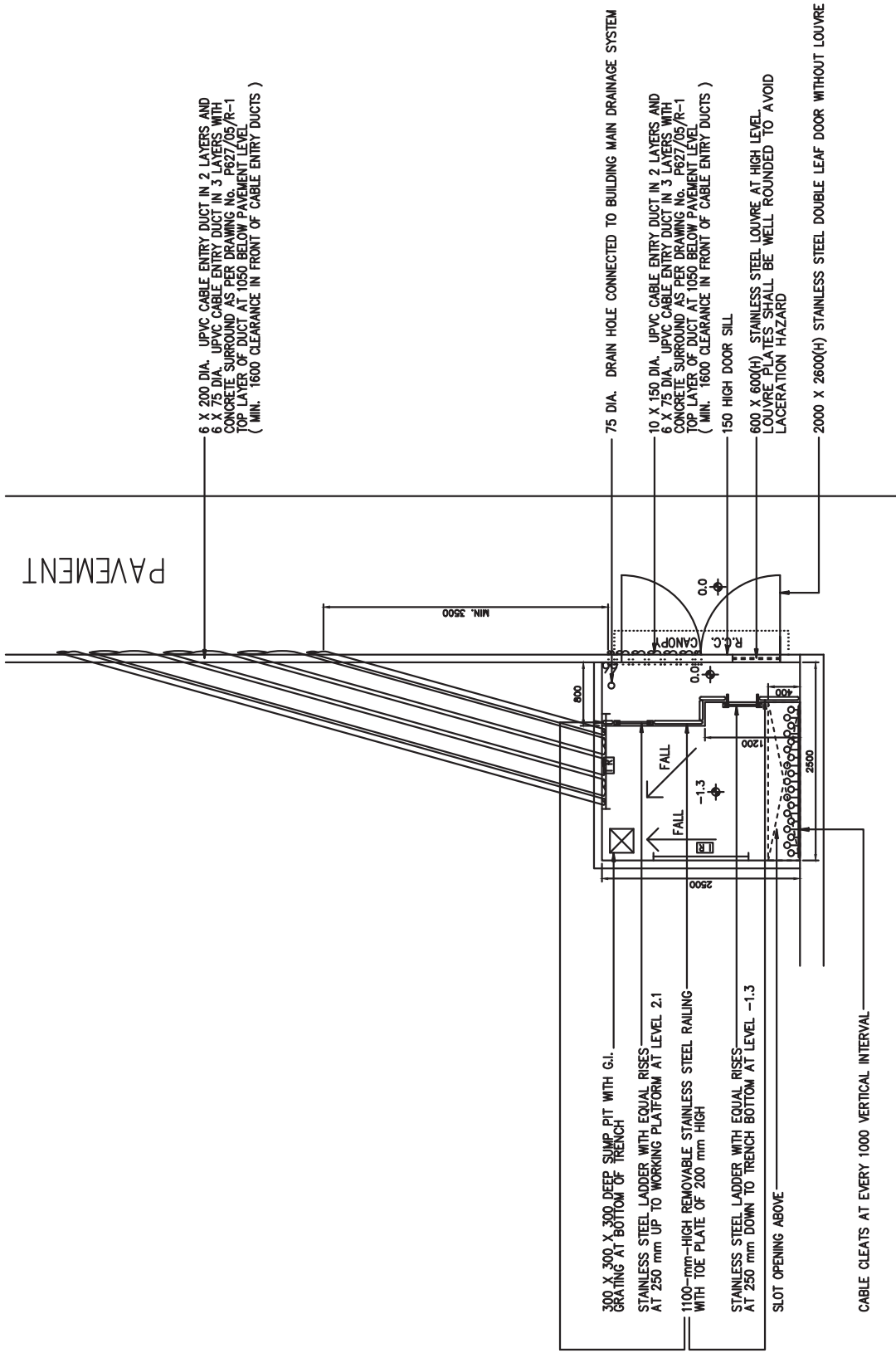

PLAN OF HK ELECTRIC'S CABLE RISER DUCT ROOM AT G/F

Drg. No. GCS/3/14

TYPICAL LAYOUT FOR SINGLE TRANSFORMER FIRST LEVEL SUBSTATION
 WITH HV & LV COMPARTMENTS (P381/98/R-6) SHEET 3 OF 6

NOTE : ALL DIMENSIONS ARE IN mm.

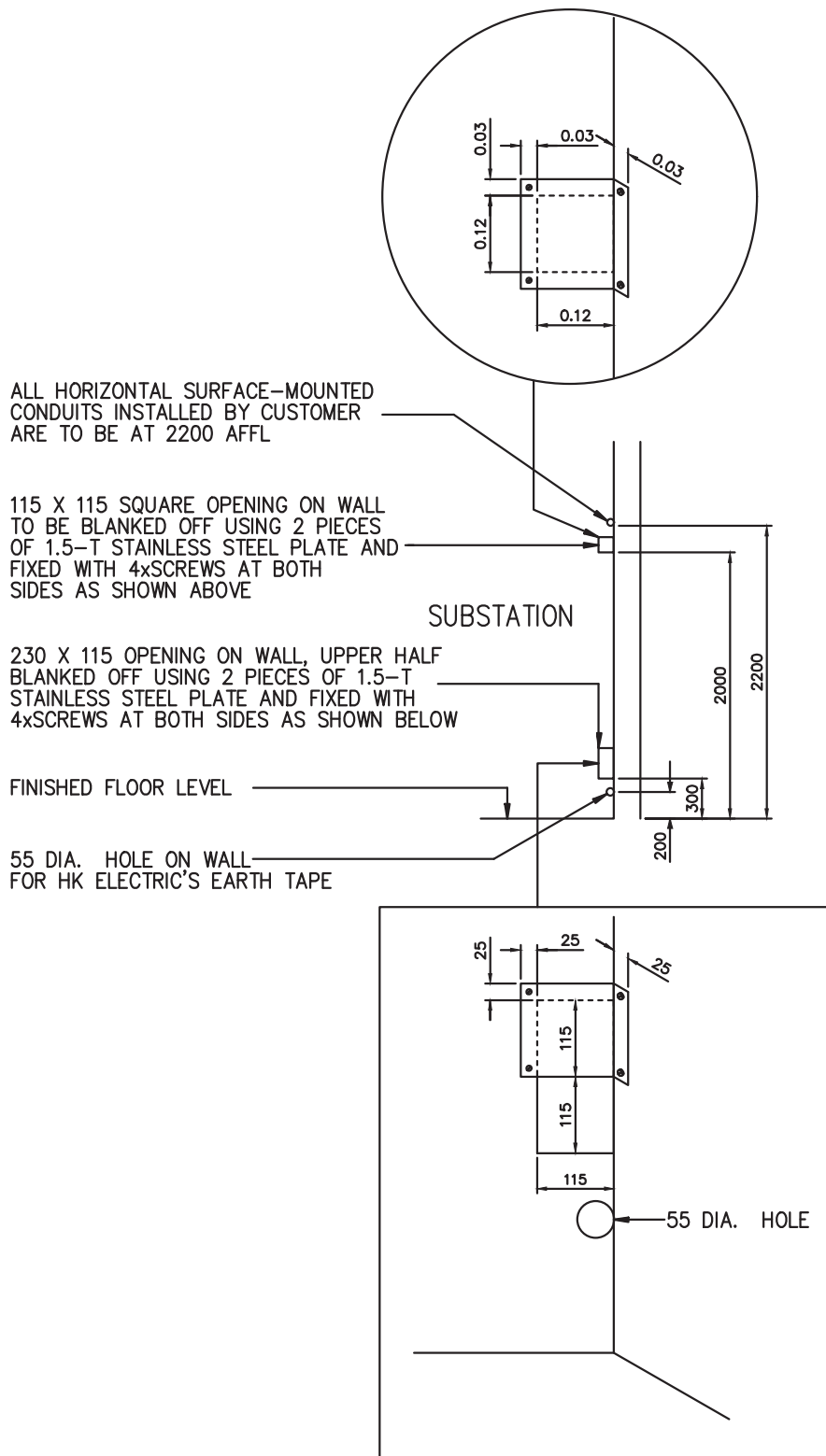

DETAIL 'A'
(NOT TO SCALE)

NOTE : ALL DIMENSIONS ARE IN mm.

DRG. NO. GCS/3/14
TYPICAL LAYOUT FOR SINGLE TRANSFORMER
FIRST LEVEL SUBSTATION WITH HV & LV
COMPARTMENTS (P381/98/R-6) SHEET 4 OF 6

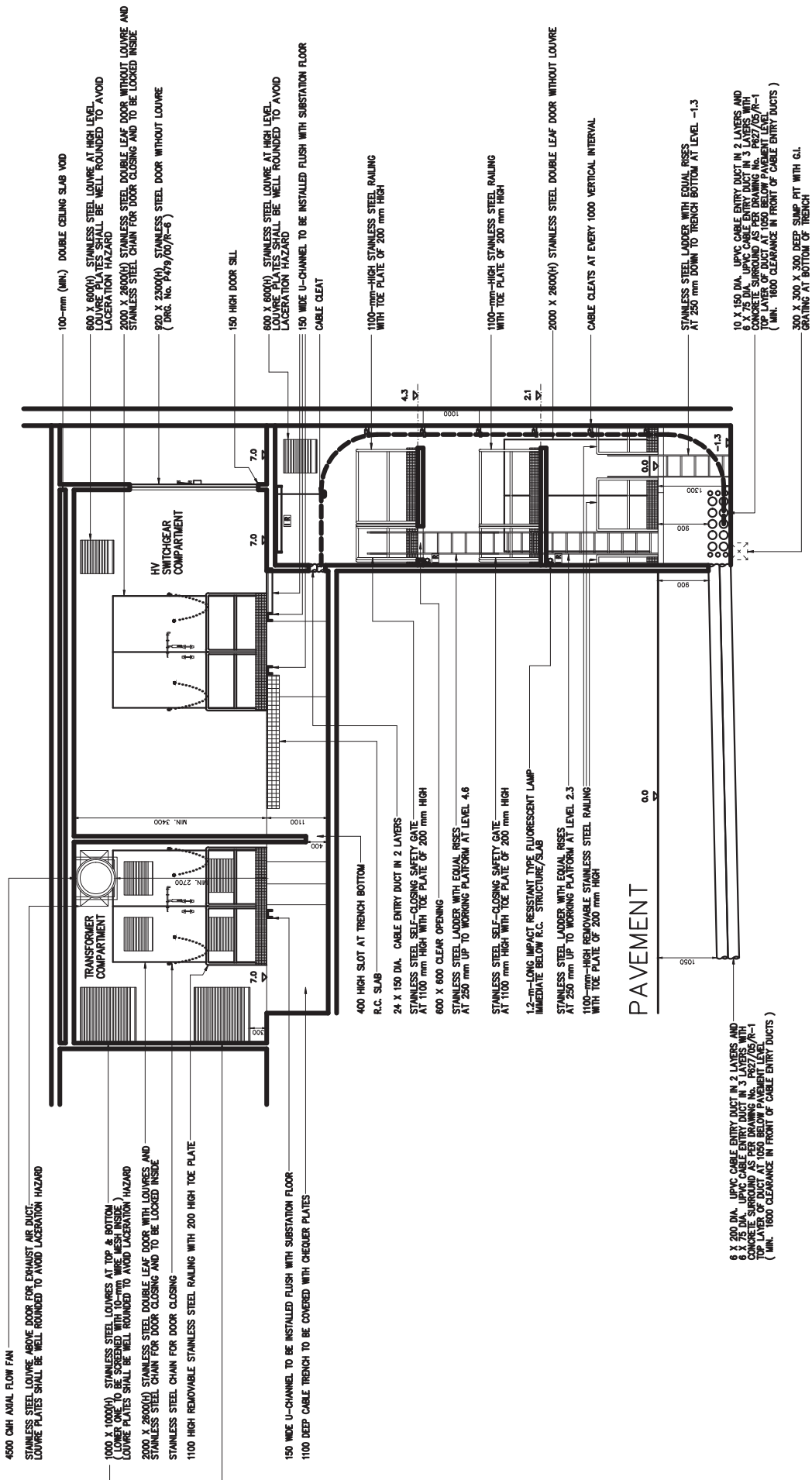

SECTION 'X - X'

Drg. No. GCS/3/14

NOTE : ALL DIMENSIONS ARE IN mm.

TYPICAL LAYOUT FOR SINGLE TRANSFORMER FIRST LEVEL SUBSTATION
WITH HV & LV COMPARTMENTS (P381/98/R-6) SHEET 5 OF 6

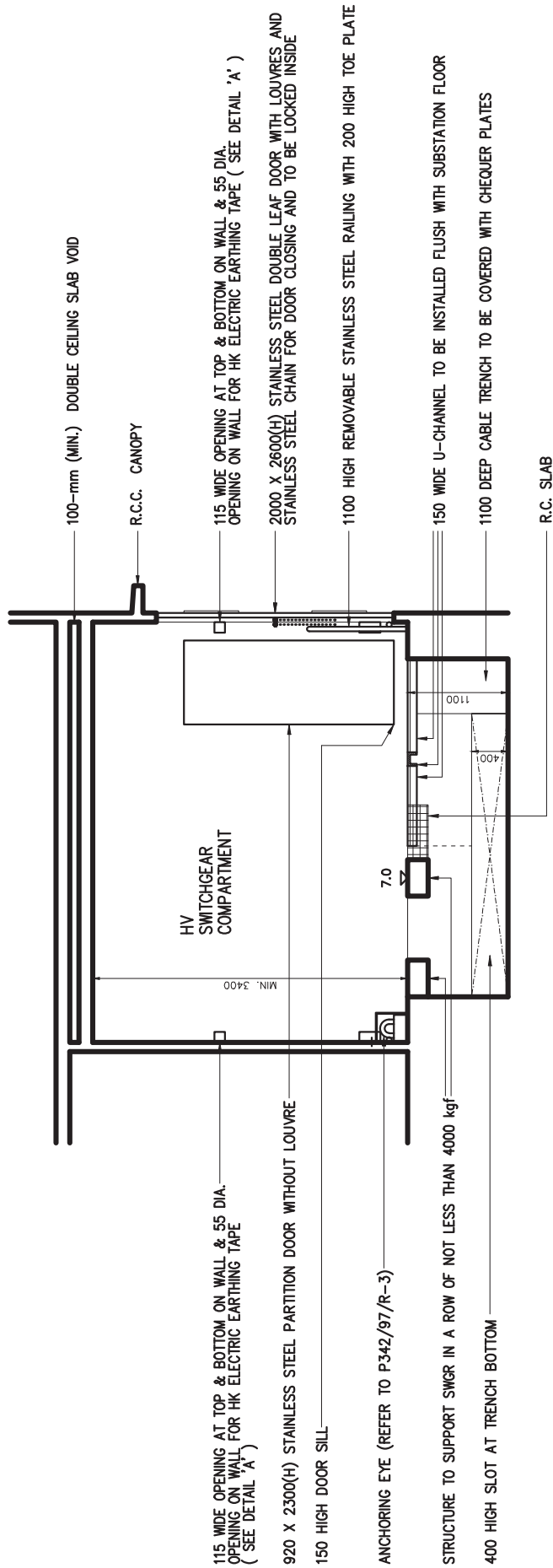











SECTION 'Y' - 'Y'

NOTE : ALL DIMENSIONS ARE IN mm.

Drg. No. GCS/3/14
TYPICAL LAYOUT FOR SINGLE TRANSFORMER FIRST LEVEL SUBSTATION
WITH HV & LV COMPARTMENTS (P381/98/R-6) SHEET 6 OF 6

LEGEND FOR DRAWING NOS. GCS/3/12, GCS/3/13 AND GCS/3/14

<p>ENCL. B/B = L.V. BUSBARS ENCLOSED IN STEEL ADAPTER TRUNKING OF L.V. PANEL</p> <p>WB = STAINLESS STEEL WRITING BOARD (400W x 300D AT 1200 AFFL)</p> <p>CAP BANK = FLOOR MOUNTED 200 KVAR POWER FACTOR CORRECTION EQUIPMENT</p> <p>VFC = VENT FAN CONTROL BOX WITH BUILT-IN ISOLATOR SWITCH (250W x 1000H x 200D)</p> <p>TO BE PROVIDED BY HK ELECTRIC AND INSTALLED BY CUSTOMER</p> <p>TEL = TEL/PILOT CABLE MARSHALLING BOX (500W x 870H x 150D)</p> <p>BATT = BATTERY & CHARGER CUBICLE FOR CIRCUIT BREAKER (1200W x 1900H x 600D)</p> <p>BATT LV = CUBICLE FOR BATTERY CHARGER LV SUPPLY (300W x 200H x 100D)</p> <p>TO BE SUPPLIED & INSTALLED BY CUSTOMER</p> <p>OPT = OPTICAL FIBRE CABLE MARSHALLING BOX (650W x 700H x 200D)</p> <p>RTU = REMOTE TERMINAL UNIT CUBICLE (600W x 1400H x 300D)</p> <p>CBMB = CIRCUIT BREAKER MARSHALLING BOX (250W x 700H x 150D)</p> <p>LVT = LV FEEDER TRANSDUCER BOX (300W x 1200H x 250D)</p> <p>TXT = TRANSFORMER TRANSDUCER BOX (300W x 700H x 250D)</p> <p>MCBB = MAIN MCB BOARD (MAX. 300 WIDE) BY CUSTOMER</p> <p>COMHUB = COMMUNICATION HUB CUBICLE (500W x 800H x 300D)</p> <p>AFFL = ABOVE FINISHED FLOOR LEVEL</p> <p>TMC = TARIFF METER COMMUNICATION BOX</p> <p>2 Nos. TO BE PROVIDED BY HK ELECTRIC AND INSTALLED BY CUSTOMER</p> <p>- SPACE OF 600W x 1200H x 300D SHALL BE RESERVED FOR THE TMC BOX INSIDE SUBSTATION</p> <p>- A 13 A FUSED SPUR UNIT AT 800 AFFL ADJACENT TO THE TMC BOX INSIDE SUBSTATION BY CUSTOMER (600W x 2000H x 350D)</p>	<p> = TELEPHONE SOCKET (CENTRE AT 1300 AFFL) TO BE PROVIDED BY HK ELECTRIC AND INSTALLED BY CUSTOMER</p> <p> = TWIN 13 A SOCKET AT 800 AFFL</p> <p> = 13 A FUSED SPUR UNIT AT 800 AFFL</p> <p> = TERMINATION BOX FOR EXHAUST FAN OR AXIAL FLOW FAN</p> <p> = 1.2 m 40 W FLUORESCENT LAMP AT 2800 AFFL</p> <p> = TWIN 1.2 m 40 W FLUORESCENT LAMP AT 2800 AFFL</p> <p> = LIGHTING SWITCH AT 1400-1600 AFFL (HV CABLE PIT LIGHTING)</p> <p> = TWO WAY LIGHTING SWITCH AT 1400-1600 AFFL (SUBSTATION LIGHTING)</p> <p> = CABLE TRENCH TO BE COVERED WITH CHEQUER PLATES</p> <p> = CHEQUER PLATES FABRICATED TO DIMENSIONS SPECIFIED. VERTICAL SUPPORT SHOULD NOT BE INSTALLED UNDER THE CHEQUER PLATES MARKED WITH AN ' * ' .</p>
---	--

Notes for Drawing Nos. GCS/3/12, GCS/3/13 & GCS/3/14

DETAILED REQUIREMENTS OF SUBSTATION

1. BUILDER'S WORK

- 1.1 No construction joint nor expansion joint shall be constructed within a substation and at the substation enclosure.
- 1.2 Unless otherwise specified in the substation layout drawing, the substation floor level should be at or above +6.0 m P.D. and substation shall have a clear headroom of 3400 mm. The substation floor shall be designed and constructed to withstand the weight of transformer, its associated HV switchgear and control equipment, each set of which is 10,000 kgf. The substation structure shall be designed to an average floor loading of not less than 20 kPa. Also all the floor area within the substation must be capable of withstanding a concentrated load of 100 kN over two Nos. of 40-mm x 600-mm rectangular strips which are the bottom channels of the above equipment. For those substations to be installed with HV switchgear only or those substations with a separate compartment solely for housing HV switchgear only, the substation floor designed to an average floor loading of not less than 10 kPa to withstand the weight of HV switchgear in such substations can be accepted. Before handing over the substation, the architect must submit detailed structural drawings, structure calculation and a certificate duly signed by a registered structural engineer, indicating that the substation structure has been designed and constructed to such requirements for HK Electric record.
- 1.3 The wall and ceiling of substation must be of construction including material and thickness, etc., complying with regulations of Fire Services Department (FSD) and Buildings Department. The substation wall shall preferably be of reinforced concrete construction, but brick of clay to BS.3921, concrete brick to BS.6073 can also be accepted. Hollow blockwork in the substation will not be accepted.
- 1.4 The substation wall and ceiling shall be cemented, sand plastered and finished with one coat of liquid prepolymer sealer and two finishing coats of acrylic resin based coating in gloss white finish. Substation floor shall be cemented, sand rendered in trowelled smooth finish. For anti-skid reasons, no coating nor painting shall be applied on the substation floor.
- 1.5 Non-slip strip inserts shall be installed at the edges of steps as specified in the latest edition of "General Specification for Building" by Architectural Services Department (ASD) of Hong Kong SAR Government, at:
 - i. staircase within the area to be locked up by HK Electric; and
 - ii. staircase outside the area to be locked up by HK Electric, but forming part of the route of escape for the substation.

Notes for Drawing Nos. GCS/3/12, GCS/3/13 & GCS/3/14

- 1.6 Substation wall and ceiling shall be finished to a true plane and to correct line and level. Maximum deviation permitted in surfaces shall be 3 mm from a 1800-mm straight edge. Substation floor shall be finished to a true plane and to extremely correct line and level. Maximum deviation permitted in surfaces of substation floor shall be 2 mm from a 1800-mm straight edge. For steelwork, maximum deviation shall be 2 mm from a 1800-mm straight edge.
- 1.7 Unless otherwise specified by HK Electric, all the building work, structural work and steelwork for the substation shall comply with the latest edition of "General Specification for Building" by ASD.
- 1.8 Unless otherwise specified by HK Electric, all exposed steelwork for substation shall be hot dip galvanized to BS EN ISO 1461.
- 1.9 Unless otherwise specified, all trenches shall be covered with 7-mm-thick hot dip galvanised steel chequer plates according to drawing No. P76/89/R-5.
- 1.10 Where removable precast concrete slabs are provided to cover preformed trench after cable installation, each piece of concrete slab shall be provided with lifting eyes and shall not weigh above 80 kgf. The precast concrete slabs shall be numbered in a sequential order by painting numbers of 50 mm high in white colour on both surfaces of each precast concrete slab so as to facilitate reinstatement of precast concrete slabs after cables installed. A sketch in permanent manner showing the layout and numbering of precast concrete slabs shall be posted on the substation wall for reference. Where the slabs are along the route of transportation of substation equipment, the slabs shall be capable of withstanding an average loading of 20 kPa. Otherwise the slabs shall withstand 10 kPa. Certificate by a registered structural engineer shall be submitted.
- 1.11 Where G.I. gratings of heavy duty type are specified to cover cable trench or cable pit, the G.I. gratings shall be fabricated with load bars of not less than 25 mm x 3 mm in cross-section, in grid size of approximately 30 mm x 100 mm and in weight of not less than 20 kgf/m². The gratings shall withstand a uniformly distributed load of 4 kPa without any permanent deformation. It shall be ensured that the deflection across the span shall not exceed 4 mm when a test load of 16 kPa is uniformly applied. Details of load table and catalogue of the gratings shall be submitted by customer to HK Electric for record.

Notes for Drawing Nos. GCS/3/12, GCS/3/13 & GCS/3/14

- 1.12 The drain hole at substation floor or at cable chamber floor shall be connected to the building main drainage system for discharging lodged water at substation trench and the position is shown in substation layout drawing. The drain shall be equipped with a non-return valve as a flood gate to prevent the backward flow of drain water into the substation. Such non-return valve should be operated by gravity flow only but not for pressurized application. Details of non-return valve and layout plan of drainage system connecting to the drain hole at substation floor shall be submitted by customer to HK Electric for record.

A UPVC drain pipe of 75 mm diameter shall be provided with the drain hole for the discharge pipe of HK Electric portable pump. UPVC screw type cap shall be installed on the drain pipe to prevent odour/waste water overflow to the substation in case the flood gate fails. The drain hole shall be covered with a stainless steel lid of 3 mm thick, engraved "FLOOR DRAIN" about 8-mm letter high on external surface of the lid. The lid shall be fixed using 4 Nos. of 5-mm-diameter stainless steel screw with counter-sunk Philip screw head and air-tight gasket or O-ring. The lid and the fixing screws shall be flush with the finished floor surface.

1.13 SUBSTATION CEILING

Except for the dedicated staircase/passage within the area locked up by HK Electric for personnel access and equipment transportation only but outside HV switchgear and transformer compartments, the entire substation ceiling shall be of double reinforced concrete slab construction. The following requirements shall be met for all types of substations:

- a. The clear separation between the upper slab and the lower slab shall not be less than 100 mm. The thickness of lower slab shall not be less than 125 mm.
- b. All finished surfaces of lower slab shall be smooth, firm and free of voids, surface projections, loose materials, oil, grease and all foreign matter. No pipes, ducts, conduits nor services of any nature are to be embedded inside the lower slab.
- c. No drain pipes shall be allowed to run inside the substation enclosure.
- d. No timber left in formwork shall be allowed within the separation void.
- e. The top surface of the lower slab shall be designed with gravity fall of 1:100 to avoid ponding of water. At least two drain holes with drain pipes of not less than 38 mm diameter shall be provided for the lower slab to discharge water to outside of the substation.

Notes for Drawing Nos. GCS/3/12, GCS/3/13 & GCS/3/14

- f. A side inspection panel of minimum size of 150 mm wide by 100 mm high shall be provided to inspect the void between the upper and lower slabs. The side inspection panel shall be easily accessible from public area and be fitted with stainless steel label engraved "SUBSTATION DOUBLE-SLAB CEILING INSPECTION PANEL 電力分站雙層天花板檢查面板". The characters shall be in minimum 10 mm high in black colour. The side inspection panel shall be fixed using stainless steel screws.
- g. In case the lower slab is divided into multi-compartment by ceiling beams, each compartment shall have its own drain holes/drain pipes and side inspection panel.
- h. A caution label of 300 mm by 200 mm shall be posted immediately adjacent to each entrance of substation stating "DOUBLE-SLAB CEILING! NO DRILLING WORK!" and the Chinese translation 「雙層天花板！禁止鑽探！」. Same bilingual wording shall be stencil painted on the ceiling in red in character not less than 75 mm high at every 5 m interval.
- i. Unless otherwise specified in this Drawing, the lower and upper slabs shall have waterproofing and water tightness conforming to the requirements regarding material and workmanship on "Roofing" as stipulated in the latest edition of General Specification for Building by ASD.
- j. Drainage plan for lower and upper slabs, waterproofing details for lower and upper slabs and waterproofing details for drain points serving lower and upper slabs shall be submitted. Cementitious type waterproofing for double slab will not be accepted.

Waterproofing material for upper and lower slab shall be materials of proprietary sheet or liquid membrane type roofing system. Proprietary roofing system shall be laid by specialist contractors.

The asphalt/bituminous waterproof sheet membrane to ASTM standard, thickness not less than 3 mm and longitudinal elongation not less than 200% will be acceptable:

Other types of membrane, provided that technical details are submitted indicating equivalent waterproofing performance, will also be considered.

Before commencing work, the contractor shall demonstrate on site that all adhesives and materials are fully compatible and shall be certified by the suppliers/manufacturers in writing.

Notes for Drawing Nos. GCS/3/12, GCS/3/13 & GCS/3/14

- k. Waterproofing material shall be wrapped onto the inner face of water outlet or any case-in drains and drain pipes.
- l. A copy of design drawing clearly indicating the locations of the substation ceiling, drain holes, drain pipes, void area, vertical grating, side inspection panel etc. shall be submitted at early design stage.
- m. An as-built drawing for substation ceiling shall be certified by an Authorised Person (Cap.123) and be submitted to HK Electric at the time of substation inspection. The as-built drawing shall clearly indicate the locations of the drain holes, drain pipes, side inspection panel. A copy of the drawing shall be laminated and posted on substation wall for quick reference on site.
- n. To ensure the effectiveness of waterproofing system for the double slab, the following tests / inspections shall be carried out at the time of substation inspection and the details of results shall be certified by an Authorised Person and submitted to HK Electric:
 - i. Flood test on lower slab with minimum 50-mm-depth water for at least 72 hours;
 - ii. Visual inspection on soffit of lower slab after the flood test;
 - iii. Flood test on upper slab with minimum 150-mm-depth water for at least 72 hours;
 - iv. CCTV inspection for soffit of upper slab through the Side Inspection Panel after the flood test; A DVD/VCD showing the CCTV inspection through the side inspection panel after the flood test shall be submitted to HK Electric for reference and record; and
 - v. The separation void shall be left clean and dry after the flood tests.

Notes for Drawing Nos. GCS/3/12, GCS/3/13 & GCS/3/14

2. CABLE ENTRY TO SUBSTATION

- 2.1 The architect is required to obtain information from utility companies and conduct site survey (including trial trenches excavation) regarding the details of underground services and roadside trees in the vicinity of substation. The architect is to ensure early in the design stage that the cable entry points to the substation will not be obstructed by other underground services or located within the no-excavation zone of any roadside tree according to Register of Old and Valuable Trees of LCSD and code of practice published by authorities of HKSAR Government. Details of underground services and any roadside trees near cable entries shall be indicated on the Ground Floor Plan submitted to HK Electric.
- 2.2 Normally the width of cable trench to be excavated for commissioning a new substation shall be taken as 1000 mm. The architect shall arrange excavation at the cable entry points within the site boundary for inspection by HK Electric engineer during hand-over of the substation. Where necessary the architect shall be responsible for clearing underground obstacles with other utility companies and any road side trees near cable entries before hand-over of substation.
- 2.3 Unless otherwise specified, all the cable entry point shall be at 1050 mm to 1300 mm below the pavement level outside the substation.
- 2.4 The cable entry of substation shall be properly sealed and watertight against ingress of water by the developer.
 - a. The last section of 4 m long (max) of 150-mm and 75-mm UPVC cable ducts will be provided by HK Electric. For cable ducts longer than 4m, the extra lengths of cable ducts are to be provided by the developer. Cable ducts of diameter other than 150 mm or 75 mm shall also be provided by developer.
 - b. The developer is required to collect UPVC ducts, duct spacers, sockets & end caps suitable for UPVC ducts or sleeves in nominal diameter of 150 mm and 75 mm provided and delivered to site by HK Electric. The developer is also required to install the cable ducts at site to ensure ducts or sleeves are constructed with correct spacing and level before concrete surroundings and application of sealings according to drawing No. P627/05/R-1.
 - c. All cable entry ducts or sleeves shall be capped by UPVC cap and sealed against water ingress or any noxious or explosive liquid or gas into the substation at the outside of substation before handing over the substation to HK Electric.

Notes for Drawing Nos. GCS/3/12, GCS/3/13 & GCS/3/14

- d. The developer shall be responsible for re-sealing the occupied ducts or sleeves using cementitious mortar with waterproofing additive and/or expansible polyurethane foam or other waterproofing material at the ends outside substation of the ducts or sleeves after installation of cables by HK Electric. The thickness of sealant shall not exceed 75 mm so as to facilitate future removal of sealant inside the ducts when cables are installed by HK Electric. Fibre-glass cotton can be inserted inside the ducts to separate the sealants where necessary.
- 2.5 Where the substation entrance is via back lane, the architect shall be responsible for aspects of flooding and illegal structure up to the point of public access which will obstruct the equipment transportation and cabling works by HK Electric. For preformed cable trench inside customer's premises leading to the substation, suitable drains should be included to prevent lodgement of water inside the preformed trench. The preformed cable trench and draw pits (if any) shall be fully filled up with nylon sandbags by the builder after HK Electric cables have been installed.
 - 2.6 Ducts or sleeves other than substation cable entry duct shall be of G.I. or UPVC as specified. Where UPVC ducts or sleeves of nominal diameter 150 mm are specified, the material shall comply with BS 3506:1969, Class D and internal diameter shall be 146 mm +/-1 mm in order to suit the duct plugs used by HK Electric. Ducts of 200 mm diameter shall also comply with BS 3506:1969, Class D. If required, sockets shall be used to joint up duct lengths to ensure that the inside surface of ducts and sockets is smooth after being installed and assembled together.
3. SUBSTATION LIGHTING & POWER
 - 3.1 The installation of substation lighting and power must comply with Electricity Ordinance, Electricity (Wiring) Regulations and HK Electric Supply Rules.
 - 3.2 Unless otherwise specified and except those wirings passing from customer's switchroom to HK Electric substation, electrical wirings shall be enclosed in surface mounted G.I. conduit. Conductor size of wirings to be controlled by 5-A or 6-A MCB shall be of 1.5 mm² Cu and similarly 2.5 mm² Cu for 15-A or 16-A MCB; 6 mm² Cu for 30-A or 32-A MCB. Phase identification using L1, L2, L3 and N for 3-phase supply or L and N for 1-phase supply should be provided for all switches and final circuits. L1, L2, L3 label shall be attached to socket outlet and lighting switch to denote the supply phase.
 - 3.3 The main MCB for substation lighting and power shall be of TP&N 4-pole construction. All MCB used shall have a breaking capacity of not less than 9 kA.
 - 3.4 A 32-A TP&N 4-pole 3-position selection switch supplied by HK Electric for connection of supply to substation main MCB board shall be collected and installed by customer according to Drawing No. P561/01/R-10.

Notes for Drawing Nos. GCS/3/12, GCS/3/13 & GCS/3/14

- 3.5 Unless otherwise specified, fluorescent lamp on wall shall be at 2800 mm above substation floor level. For substation with headroom over 3600 mm, the lamps below ceiling shall be supported such that the lamps are at 3200 mm above ground. Lighting in substation shall be fed by at least two final circuits of different phases. The layout of lamps shall be arranged in such a way that adjacent lamps are fed by different final circuits. The number of fluorescent tubes fed by each final circuit shall be approximately equal and no more than 8 per circuit.
- 3.6 Normal type fluorescent lamp fitting shall be installed unless Impact Resistant Type Fluorescent Lamp Fitting is specified in the substation layout drawing. Impact Resistant Type Fluorescent Lamp Fitting will be marked "IR" next to the symbol in the drawing, and shall be installed in area of cable chamber, cable pit and cable shaft. The Impact Resistant Type Fluorescent Lamp Fitting shall comply with either (a) or (b) of the following requirements:
- a. Diffuser of flame retardant material tested to withstand a mechanical shock of not less than 10 Joules to EN60598 and stainless steel toggles as diffuser clips shall be fitted onto the lamp fitting.
 - b. A wire guard in approximately mesh size of 25 mm x 75 mm made from stainless steel wire and not thinner than 3.25 mm diameter shall be fitted onto the lamp fitting or wall by stainless steel screws. The wire guard shall be of swing-down design and locked by wing-head nuts on both sides to facilitate replacement of fluorescent lamp.
- 3.7 Fluorescent lamp to be installed in HV cable pit shall be controlled by an independent switch via an independent MCB, impact resistant type and fixed as close to the top of R.C. slabs or beams as practicable.
- 3.8 Emergency lighting, if so required by FSD, shall be backed up according to FSD's requirements. Each emergency light shall be labelled "EMERGENCY LIGHT" and the Chinese translation 「緊急照明」. Future maintenance/replacement of such emergency lighting and the associated fitting shall be the responsibilities of customer.
- 3.9 Socket outlets in substation shall be of 13 A in ring circuits and be provided with L1, L2, L3 labels for phase identification in permanent manner. Socket outlets shall be installed at 800 mm above substation floor level unless otherwise specified. Socket outlets to be installed in HV cable pit shall be protected by an independent MCB, to IP65 standard and fixed as close to the top of R.C. slab or beam as practicable.

Notes for Drawing Nos. GCS/3/12, GCS/3/13 & GCS/3/14

- 3.10 Test on phase sequence, earth fault loop impedance, operating characteristics of residue current device and 500-V megger test on the substation lighting and power installation shall be carried out and be witnessed by HK Electric engineer at the time of substation hand-over. Customer shall submit a copy of Work Completion Certificate (Government Form WR1) duly signed by a registered electrical worker for lighting & power installation in substation before substation handing over.
- 3.11 i. For staircase, passage, etc. within the area to be locked up by HK Electric, where layout of fluorescent lamps is not specified by HK Electric, customer shall ensure that the lamps are installed so as to provide an illumination of not less than 150 lux measured at floor level.
- ii. For staircase, passage, etc. outside the area to be locked up by HK Electric, but forming part of the route of escape for the substation, illumination must be provided according to FSD's requirements. Also the electricity supply to the lightings shall be from the essential board in the building.
- 3.12 Exposed metallic parts inside substation should be bonded to the substation earthing connection in the manner laid down in Electricity (Wiring) Regulations. Brass or stainless steel bolts, nuts and washers shall be used at the equipotential bonding of exposed metallic parts for long lasting purpose.
- 3.13 Before energization of substation by HK Electric, the temporary wirings for substation lighting and power shall be properly connected to the 5-pin male type socket of the 32-A TP&N. 4-pole 3-position selection switch via a female connector having corresponding rating and dimensions by customer for safety purpose.

4. CONDUITS IN SUBSTATION

- 4.1 Conduits, be they metallic or PVC, shall be supported and fixed to ceiling/side wall at an interval of not more than 1200 mm. The method of anchoring conduits must be by red-head or similar device. Anchoring by raw plug or wood plug will not be accepted. No painting of G.I. conduit is required.
- 4.2 Unless otherwise specified, conduits shall not traverse low voltage busbar route nor be running above HK Electric supply equipment marked on the substation drawing. All horizontal conduits of any purposes shall be installed at a level of 2200 mm above substation floor. Connection to cubicles/boxes mounted onto substation wall shall be by means of top entry vertical conduits dropped from the horizontal conduits. Where necessary to install conduits across substation door, the conduits shall be fitted above the door.
- 4.3 All electrical metallic conduits shall be continuous with good electrical joints at boxes and couplings etc.

Notes for Drawing Nos. GCS/3/12, GCS/3/13 & GCS/3/14

4.4 For the purpose of installation of HK Electric trunking and earthing tapes, the 400 mm space on wall above substation floor should be free from any installation or conduit unless otherwise specified in this requirement.

5 VENTILATION SYSTEM IN SUBSTATION

5.1 Hangers for air duct shall be of U-shape, 40 mm x 7 mm thick hot dip galvanized steel plate (or equivalent size) at interval of not more than 1200 mm. Hangers shall be provided on either side of air duct joint. The method of anchoring the hanger onto the ceiling/side wall must be by red-head or similar device. Anchoring by raw plug or wood plug will not be accepted. The air duct must be securely fixed to the hangers by means of hot dip galvanized steel or stainless steel bolts and nuts with washers.

5.2 The air duct shall be made of hot dip galvanized steel sheet of not less than 0.8 mm thick. No painting of the air duct is required. The headroom under the air duct shall be 2700 mm minimum, but not greater than 3200 mm. The air duct, fan and silencers shall not traverse low voltage busbar route nor be running above HK Electric supply equipment marked on the substation drawings.

5.3 Silencers, acoustic lining and/or acoustic plenum, etc. shall be installed to reduce noise level to be not exceeding the values as stipulated in Noise Control Ordinance (NCO). In case of axial flow fans being provided by customer, the following must be submitted early at planning stage:

- a. Drawings to show the configuration of the ventilation system.
- b. Drawings to show the locations of the existing or assumed nearest noise sensitive receivers (NSR) and the corresponding distances away from the substation and supply/exhaust louvres.
- c. Detailed acoustic calculation of the ventilation system to verify compliance with the NCO, including tonality consideration, if any.
- d. Description clearly indicating the approach and methodology on which the calculation is based.
- e. A copy of the detailed references for the technical data adopted in the calculation, including catalogues of ventilation fans and silencers, attenuation figures, etc.

If the acoustic calculation is not conclusive due to any reasons, a post-commissioning noise measurement at the identified NSR with entire 1/3 octave frequency spectrum from 31.5 Hz to 16 kHz has to be carried out by the developer to ensure compliance with the NCO.

Notes for Drawing Nos. GCS/3/12, GCS/3/13 & GCS/3/14

- 5.4 The noise level measured at any location within the substation and at 2 m above finished floor level of substation shall not exceed 85 dB(A) while all the intake/exhaust fans for the substation are in operation.
- 5.5 The as-measured noise level of ventilation system must not exceed the values stipulated in Noise Control Ordinance.
- 5.6 Where two or more ventilation systems are installed, the ducting, fan, silencer, control panel and other major parts shall be numbered in a permanent manner at intervals not exceeding 3 metres.
- 5.7 Where intake fan system and exhaust fan system are installed, the ducting, fan, silencer, control panel and other major parts shall be labelled "INTAKE 入風" and "EXHAUST 出風" accordingly and direction of air flow shall be indicated by using arrows in a permanent manner. Inter-tripping control box shall be provided for the intake and exhaust fans. The customer must demonstrate by calculation and on-site measurement that the INTAKE and EXHAUST paths will not be short-circuited.
- 5.8 Unless otherwise specified by HK Electric, the air duct shall be so designed that the average air velocity at any cross-section shall not exceed 4.2 m/s.
- 5.9 For substations to be equipped with exhaust fan only, the average air velocity at exhaust louvres shall not exceed 3.0 m/s. Also the inclined angle at the gradual expansion of exhaust louvres shall not be more than 30°.
- 5.10 For substations to be equipped with intake/exhaust fans, the average air velocity at intake/exhaust louvres shall not exceed 3.0 m/s. Also the inclined angle at the gradual expansion of intake/exhaust louvres shall not be more than 30°.
- 5.11 For remote on/off control of substation ventilation system, customer is required to install fan control box(es) which will be supplied by HK Electric in the substation according to HK Electric drawing No. P382/98/R-2 before handing over the substation. A pair of dry contact (220 V, 5 A) shall be provided to HK Electric for controlling the ventilation fan if central control system is used by customer where control box provided by HK Electric is not applicable. Such details of electrical control system shall be submitted to HK Electric for approval at design stage.
- 5.12 Local emergency switch shall be provided at a level not exceeding 500 mm above the bottom of fan and within 1 metre from each ventilation fan. The switch may be installed on wall, ceiling or an independent steel framework, but shall be installed as close as possible to the ventilation fan junction box and must not be fixed onto the axial flow fan or silencers.

6. VENTILATION LOUVRES ON SUBSTATION WALL

- 6.1 Ventilation louvres shall be provided on substation walls as specified in HK Electric drawings. The constructional details are shown on drawing No. P638/06/R-1.

Notes for Drawing Nos. GCS/3/12, GCS/3/13 & GCS/3/14

- 6.2 The ventilation louvres and frame shall be made of stainless steel sheet and thickness of 1.5 mm. A frame shall be provided for louvre leaves.
- 6.3 For substations at ground level, the bottom edge of lower louvres shall be at 300 mm above finished floor level unless otherwise specified.
- 6.4 For lower louvres at ground level substations, a wire mesh with frame and handle shall be provided at the inner side. The wire mesh shall be of 10 mm x 10 mm and be made from stainless steel wire and not thinner than 2.0 mm diameter. The frame and handle of wire mesh shall be of rigid construction and be stainless steel. The frame and handle of wire mesh shall be so designed and constructed for slot-in installation and removal. Where necessary, two or more pieces of wire meshes shall be provided for large size louvre to facilitate removal and installation work. The overall weight of each wire mesh shall not exceed 25 kgf. Installation of wire mesh shall be by means of a vertical sliding-down or horizontal sliding-in action and that no bolts, nuts nor tools shall be required for fixing. It shall be ensured that the gap between frames of louvres and wire mesh after installation shall not exceed 10 mm. For easy cleaning of wire mesh, the earthing wire shall be fixed using a wing-head nut.

7. SUBSTATION DOOR

- 7.1 Ventilation louvres shall be provided on substation doors as specified in HK Electric drawings.
- 7.2 For lower louvres of ground floor substation, a wire mesh with frame and handle shall be provided at the inner side. The wire mesh shall be of 10 mm x 10 mm and be made from stainless steel wire and not thinner than 2.0 mm diameter. The frame and handle of wire mesh shall also be stainless steel and they shall be so designed and constructed for slot-in installation and removal. Installation of wire mesh shall be by means of: (a) a horizontal sliding-in action from the free edge of door leaf and then securing using a bolt; or (b) a vertical sliding-down action and that no bolts, nuts nor tools shall be required for fixing. It shall be ensured that the gap between frames of louvres and wire mesh after installation shall not exceed 10 mm. For easy cleaning of wire mesh, the earthing wire shall be fixed using a wing-head nut.
- 7.3 Substation door with its path of swing within passage of vehicular traffic or within area of car park space will not be accepted.

8. FIRE SERVICES INSTALLATION IN SUBSTATION

- 8.1 The architect shall be responsible for ensuring that the substation complies with the latest requirements set out by FSD. Unless fixed firefighting installation is definitely required by FSD, there is no need to install fixed firefighting equipment in HK Electric substation because non oil-filled high voltage switchgear and transformer(s) will be installed in the substation.

Notes for Drawing Nos. GCS/3/12, GCS/3/13 & GCS/3/14

- 8.2 Unless otherwise specified in this drawing, the installation shall comply with the latest edition of "Code of Practice for Minimum Fire Service Installations and Equipment" published by FSD. Letters or certificates certifying the compliance with the COP and the proper functioning of the fixed firefighting system (if any) shall be submitted prior to formal hand-over of substation.
- 8.3 Please note that HK Electric will install totally oil-less transformer(s) and switchgear in new substations. FSD has already granted exemption to HK Electric in the provision of portable fire extinguishers at this type of substations. Therefore, the developer is required not to include portable fire extinguishers in the substation during the building plan submission stage. During take-over of substation by HK Electric, no portable fire extinguisher shall be placed inside the substation.
- 8.4 Should fixed fighting system be required for the substation, an automatic/manual (A/M) change-over panel should be installed and the following arrangements shall be adopted.
- a. A key box of stainless steel and thickness not less than 1.5 mm shall be provided immediate adjacent to the A/M change-over panel. The key box shall be not less than 100 mm high x 150 mm wide x 100 mm deep with a hinged front cover. A lock hole of 14 mm diameter shall be provided for HK Electric pad lock to lock the key box. On the front cover of key box, an engraved label stating "KEY BOX FOR FIRE SERVICES PANEL" and Chinese translation 「消防控制台匙箱」 shall be provided.
 - b. The key for A/M change-over panel shall be attached to a stainless steel chain secured at the inside of key box. The chain must be of sufficient length to enable A/M change-over operation and chain must not break when a 500-N tensile force is applied.
 - c. Another spare key for A/M change-over panel shall be handed to HK Electric engineer during substation inspection for keeping in HK Electric operations room.
- 8.5 Fixed firefighting piping (if any) shall be supported and fixed to ceiling/side wall at an interval of not more than 1200 mm. Such piping shall not traverse low voltage busbar route nor be running above HK Electric supply equipment marked on the substation drawings. The method of anchoring fixed firefighting piping (if any) must be by red-head or similar device. Anchoring by raw plug or wood plug will not be accepted.
- 8.6 Automatic fixed firefighting installation using water within the locked area of substation is not allowed. Fixed firefighting installation (if any) should be submitted to HK Electric for approval before handing over the substation to HK Electric.

Notes for Drawing Nos. GCS/3/12, GCS/3/13 & GCS/3/14

- 8.7 Fire detection system, if required in the latest edition of "Code of Practice for Minimum Fire Service Installations and Equipment" published by FSD, shall be installed in substation. Detection heads of heat detecting type may be installed if deemed necessary.
- 8.8 Where fire dampers are required by FSD, the fire dampers shall be installed onto the external side of opening such that checking and maintenance of the fire dampers could be carried out without entering the substation. To avoid overloading of ventilation fan system, proper electrical cut-off of ventilation fan should be provided.
9. MISCELLANEOUS
- 9.1 No drain, water sewer pipes or other services are to pass through or enter substation and the exclusive access(es) to the substation or to run inside the substation enclosing.
- 9.2 Heavy duty type telephone socket outlets supplied by HK Electric shall be collected and fixed to substation wall at 1300 mm above substation floor level as specified in substation layout drawings. The fixing details are shown on drawing No. P431/99/R-1.
- 9.3 The appliance/gear and the associated I-beam or other equipment for lifting of equipment shall be with a safe working load specified by HK Electric in the substation drawing and tested with a safety factor of 2. Certificate proving such shall be submitted prior to the acceptance of the substation. The lifting appliance/gear after the initial test shall also be tested periodically in accordance with the current Factories and Industrial Undertakings (Lifting Appliances and Lifting Gear) Regulations by customers. Certified copies of such certificates of periodical test shall also be submitted to HK Electric for record.
- 9.4 Transit block shall be installed at a height measured above substation floor level as specified in the substation drawing.
- 9.5 Wall opening for emergency wirings shall be provided as indicated on drawing No. P638/06/R-1 .
- 9.6 All labels shall be engraved and be in both English and Chinese. White characters on red background shall be used for warning labels. Black characters on white background shall be used for indicative labels.
- 9.7 To inform personnel entering the substation of the route of escape from substation to open space, for:
- i. all substations not situated at ground level; and

Notes for Drawing Nos. GCS/3/12, GCS/3/13 & GCS/3/14

- ii. ground level substations where there is change in direction in the route of escape or the measured distance along the route of escape from substation door to open area exceeds 20 metres.

A plan showing the route of escape should be affixed onto the wall near the substation door. Also illuminated exit signs and directional signs at turning corners shall be provided outside substation. All the illuminated signs shall conform to FSD's requirements. Unless it is definitely required by FSD, illuminated exit signs shall not be installed inside substation area locked up by HK Electric. The future maintenance of the route of escape plan, exit sign and directional sign shall be the responsibility of the customer.

9.8 No fluorescent lamp fitting, heat detector, axial flow fan, flexible conduit for fan and emergency push button for fan shall be installed within the high level hazard zone as specified in drawing No. P346/97 unless they are at less than 2300 mm high measured from substation floor.

9.9 For safety purpose,

- a. Black/yellow strips in 50 mm high shall be painted at conspicuous positions, such as beams, slabs, removable supporting steels, etc. at top of the HV cable pit with luminous paint. The same shall be applied to locations of sudden change in level.
- b. No protruded objects which may cause injury are allowed along the passage up and down the HV cable pit.
- c. Sharp edges at the heavy duty grating and the cat ladder shall be eliminated.

9.10 An earthing bracket bonded to the building main earthing shall be provided at the cable entry of substation according to Drawing No. P574/02/R-1.

9.11 All the MCB boards, cubicles "BattLV", TMC cubicle, fan control box(es) and 32-A selector switch shall be mounted on substation wall by using Unistrut channels at the back.

9.12 The developer shall prepare the necessary Temporary Traffic Measures (TTM) proposal and obtain the approval from Transport Department (TD) and Traffic Police for HK Electric equipment transportation to the substation if the substation door is opened to carriageway designated as "Restriction Zone – Clearways" by TD or there are other site constraints that application of TTM from the Government Authorities is necessary.

Notes for Drawing Nos. GCS/3/12, GCS/3/13 & GCS/3/14

- 9.13 The developer shall arrange to revise the hoarding of the construction site at their own costs to provide sufficient space for HK Electric to excavate the cable trench outside the construction site for provision of supply if the hoarding or its foundations are found to be obstructing HK Electric trenching and cabling work.
- 9.14 Stainless steel shall mean stainless steel of grade 316 unless otherwise specified.
- 9.15 The customers in the development shall ensure that the substation equipment transportation route within the customer's premises is properly maintained and cleared from obstruction at all times. The facilities (including lifting appliances, lifting gear, freight lifts, etc.) provided by the developer for the purpose of transportation of equipment shall be properly maintained by the customers in the building at their own costs to satisfy the legal requirements.

Notes for Drawing No. GCS/3/14

1. Level of G/F is assumed at + 0.0, levels of working platforms are with reference to the high level of G/F.
2. Direct vehicular access shall be available to the front of substation door at a horizontal distance not exceeding 4 metres. Direct vehicular access shall mean accessibility of a standard 30 ton fire appliance of FSD of HKSAR Government.
3. The substation floor level must not be of 7 metres higher than the pavement level measured at centre line of substation door.
4. The gradient of access road to substation (when measured along +/-10 m horizontally from centre line of door 'A') must not be greater than 1:12.
5. There shall not be any protruded objects obstructing transportation of equipment to / from substation when measured along +/-6 m horizontally from the centre line of door 'A' and vertically from 3m of top of door 'A' down to pavement level.
6. The separation of the two cable entry points shall be not less than 3500 mm.
7. The developer/landlord shall provide haulage lug(s) inside the cable riser duct as and required by HK Electric for cable laying works. The statutory loading tests of the haulage lug(s), when required, shall be arranged by the developer / landlord. These haulage lug(s) shall be of removable type such that it (they) could be removed after completion of cable laying.

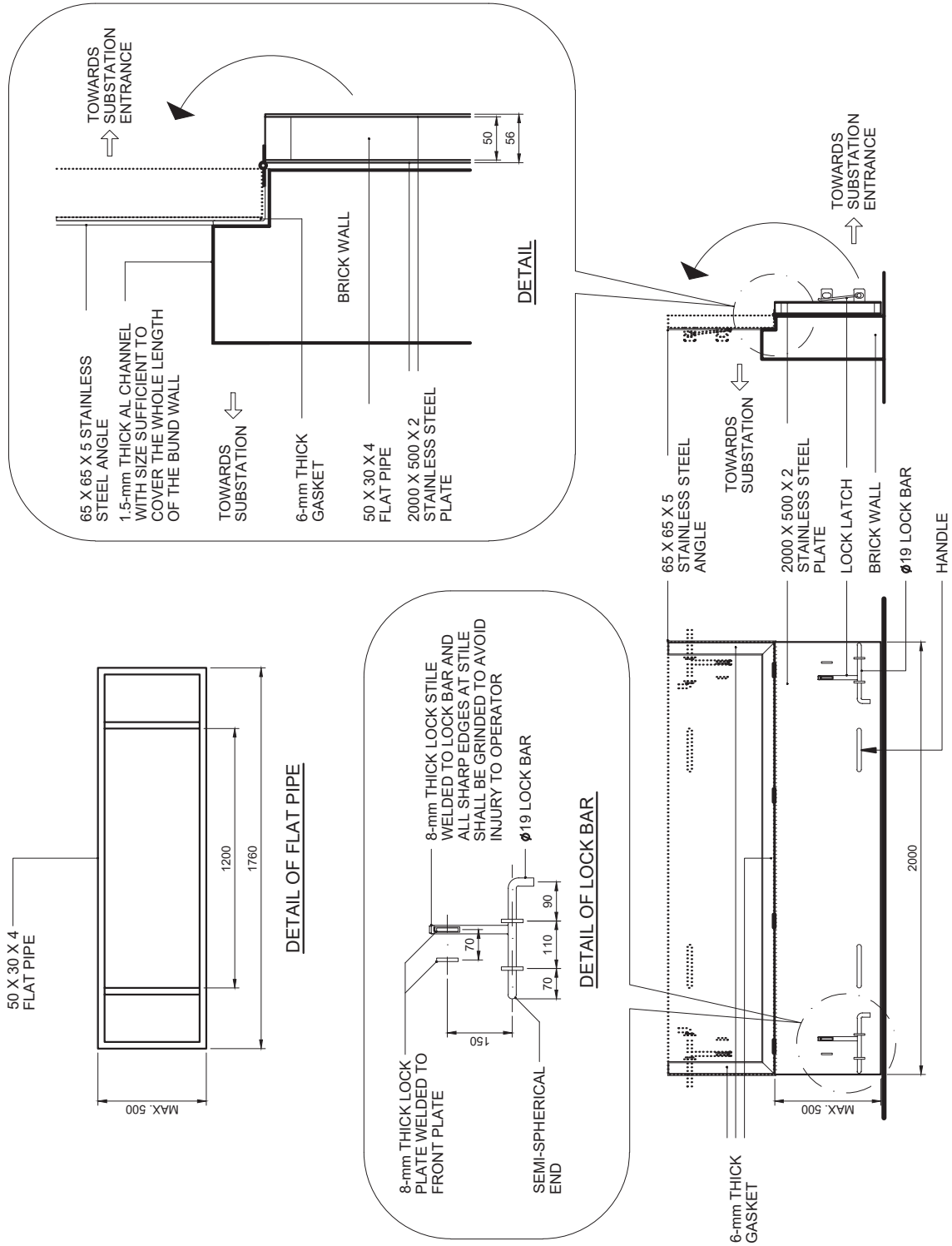

NOTE : ALL DIMENSIONS ARE IN mm.

Drg. No. GCS/3/15
BUND WALL AND FLOOD GATE FOR DISTRIBUTION SUBSTATION
 (P806/19) SHEET 1 OF 2

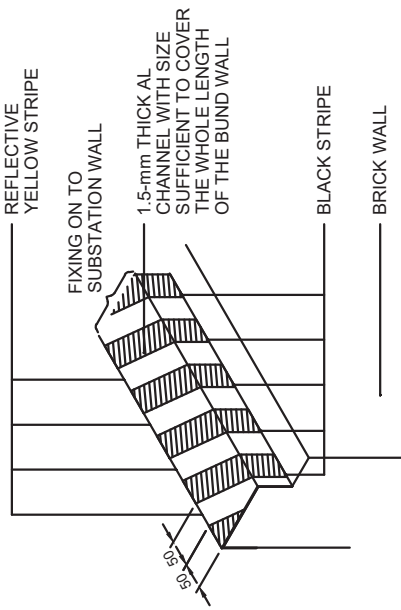

TYPICAL LAYOUT OF BUND WALL

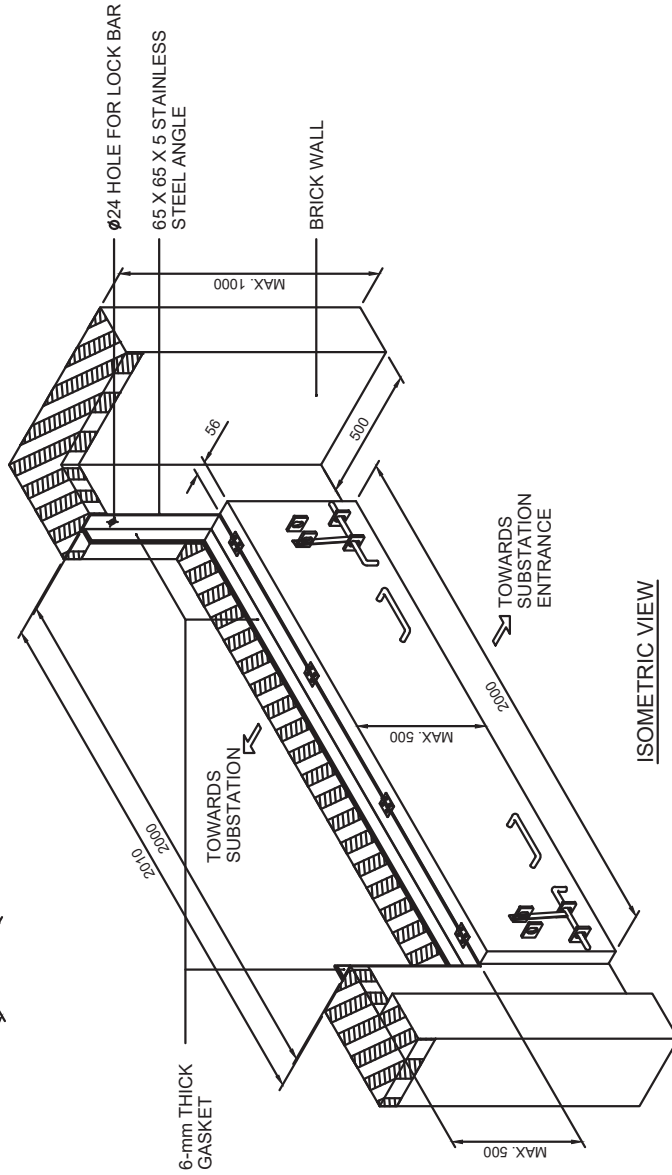
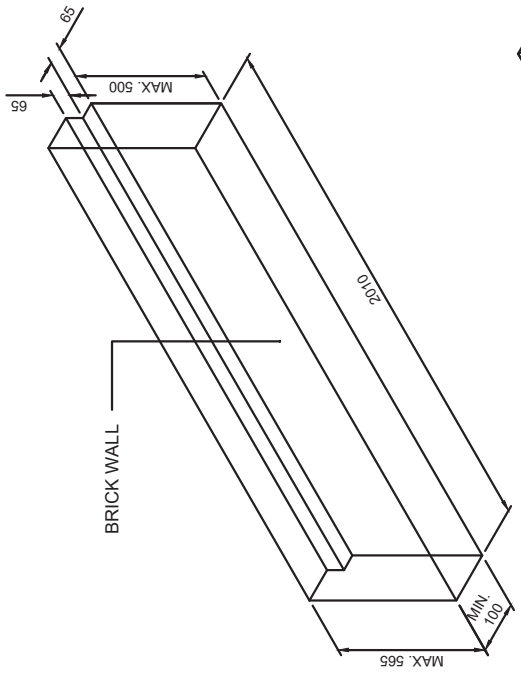

NOTE : ALL DIMENSIONS ARE IN mm.

Dr. No. GCS/3/15

BUND WALL AND FLOOD GATE FOR DISTRIBUTION SUBSTATION

(P806/19) SHEET 2 OF 2

Notes for Drawing No. GCS/3/15

1. P.D. = Principal Datum
2. Brick bund wall and flood gate shall be constructed and installed by the builder after equipment has been delivered to the substation as specified in the substation layout drawing.
3. For the bund wall and flood gate to be constructed/installed directly across the substation door opening, the maximum height of each is 500 mm. The builder should refer to the substation layout drawing regarding the heights of the bund wall and flood gate to be constructed and installed. The maximum height of bund wall outside the substation door opening is 1000 mm.
4. The top level of the bund wall or flood gate directly across the substation door opening, whichever is the highest, should be at + 6.0 m P.D. (or as specified in the substation layout drawing). If the top level of the bund wall after constructed is ≥ 6.0 m P.D. (or as specified in the substation layout drawing), no installation of flood gate is required.
5. The bund wall shall comply with the following requirements:
 - a. The bund wall shall be made of red bricks.
 - b. Typically, the bund wall shall be with overall thickness of not less than 100 mm.
 - c. Water-proofing cement sand plasters with thickness not less than 10 mm shall be applied to all surfaces of the bund wall. The surface finish of the cement sand plaster shall be smooth and free from cracks and voids.
 - d. Two layers of water-proof paint in white colour shall be applied to the bund wall after the cement sand plasters are completely dried.
 - e. After completion of the application of water-proofing material, an additional aluminium cover, which should be made of 1.5-mm thick aluminium channel with size sufficient to cover the whole length of the bund wall is required to be installed on top of the bund wall. Black/reflective yellow stripes shall be painted on the cover.
 - f. All gaps between bund wall and the substation structures shall be properly sealed with sealants.

Notes for Drawing No. GCS/3/15

6. The flood gate shall comply with the following requirements:
 - a. The flood gate shall be made of stainless steel grade 316.
 - b. The stainless steel gate shall be made of 2-mm thick front sheet including double-angle (65 x 65 x 5 mm) angle frame.
 - c. EPDM water-proof seals (6-mm thick gasket) shall be installed between double angle frame and the stainless steel gate to prevent water leakage into the substation.
 - d. Custom-made locking device with 250 mm in length shall be installed at both ends of the gate.
 - e. Two handles of \varnothing 8 shall be installed at each side of the gate at a separation of not more than 400 mm from the edge of panel.
 - f. At least four bullet hinges shall be installed along the stainless steel gate.
 - g. Water-proof cement sand grouting and water-proof sealant shall be applied to all gaps and joints around the gate.
 - h. The weight of the flood gate should not exceed 20 kgf.

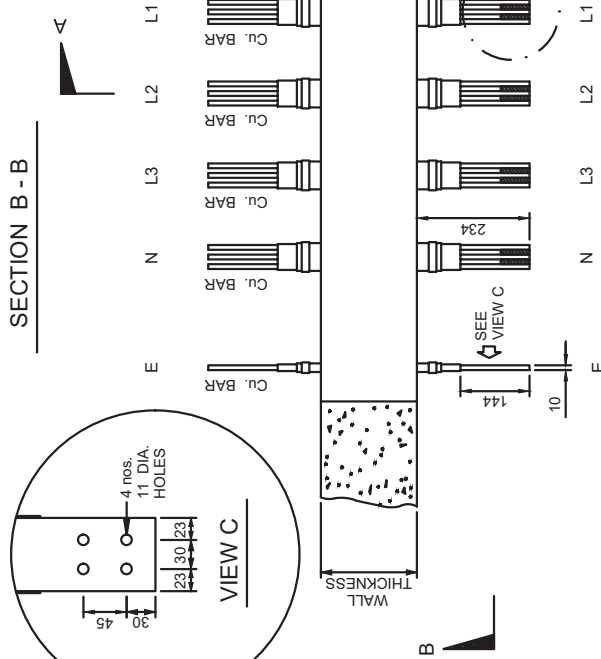
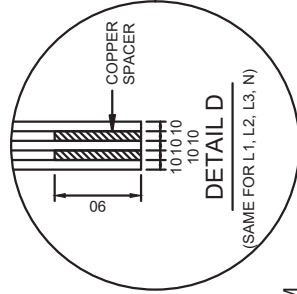
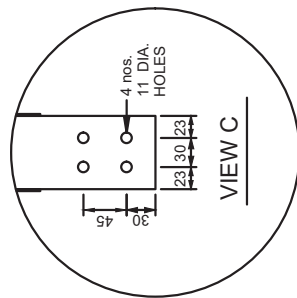
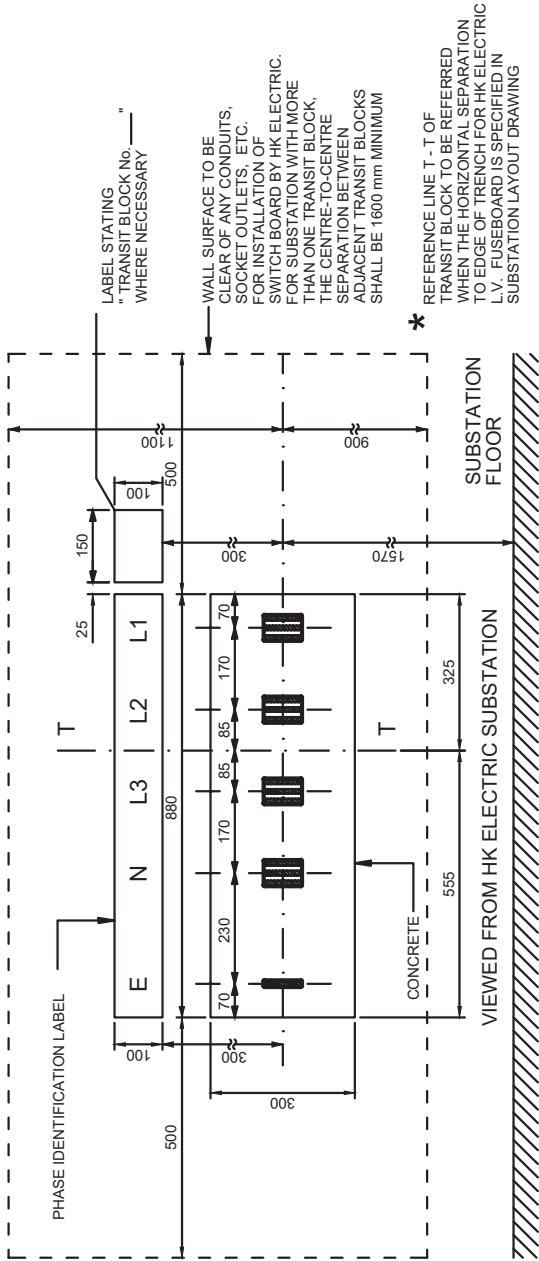

NOTES :

- THIS TRANSIT BLOCK IS FOR CUSTOMER MAIN SWITCH OF RATING NOT EXCEEDING 2500 A
- INSULATION LEVEL OF TRANSIT BLOCK SHALL BE 3 KV RMS FOR 1 MINUTE
- ALL COPPER BARS SHALL BE TINNED AND HARD DRAWN OF HIGH CONDUCTIVITY ACCORDING TO CW004A OF BSEN 13601 OR C11000 OF ASTM B187M OR EQUIVALENT
- THE FOLLOWING ENGRAVED LABELS OF INSULATED MATERIAL AND FIXED USING M6 CONCRETE ANCHORS AND M6 G.I. HEX BOLTS SHALL BE PROVIDED ON BOTH SIDES OF WALL. THE LETTERS SHALL BE IN BLACK ON WHITE BACKGROUND. THE BOTTOM EDGE OF LABEL SHALL BE AT 300 mm ABOVE THE CENTRE LINE OF TRANSIT BLOCK.

CODE	PHASE	COLOUR TAPE
L1	PHASE	COLOUR TAPES AS PER REQUIREMENTS IN ELECTRICITY (WIRING) REGULATIONS
L2	PHASE	
L3	PHASE	
N	NEUTRAL	
E	EARTH	GREEN / YELLOW

- 5A. LABEL OF 880 mm WIDE BY 100 mm HIGH MARKED WITH L1, L2, L3, N, E OR E, N, L3, L2, L1 (AS APPROPRIATE) WITH LETTER HEIGHT NOT LESS THAN 50 mm.
- 5B. WHERE MORE THAN ONE TRANSIT BLOCK ARE INSTALLED IN A SUBSTATION, LABEL INDICATING TRANSIT BLOCK NUMBERING (AS SHOWN IN SUBSTATION LAYOUT DRAWING) WITH LETTER HEIGHT NOT LESS THAN 15 mm.

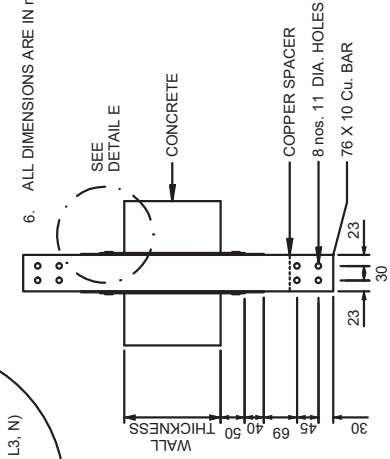
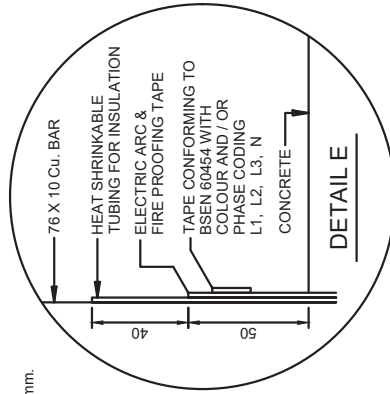

SECTION A - A
(SAME FOR L1, L2, L3, N, E)

PLAN

Dr. No. GCS/3/16
DETAILS OF LV TRANSIT BLOCK AT MID LEVEL (P314/96/R-3)

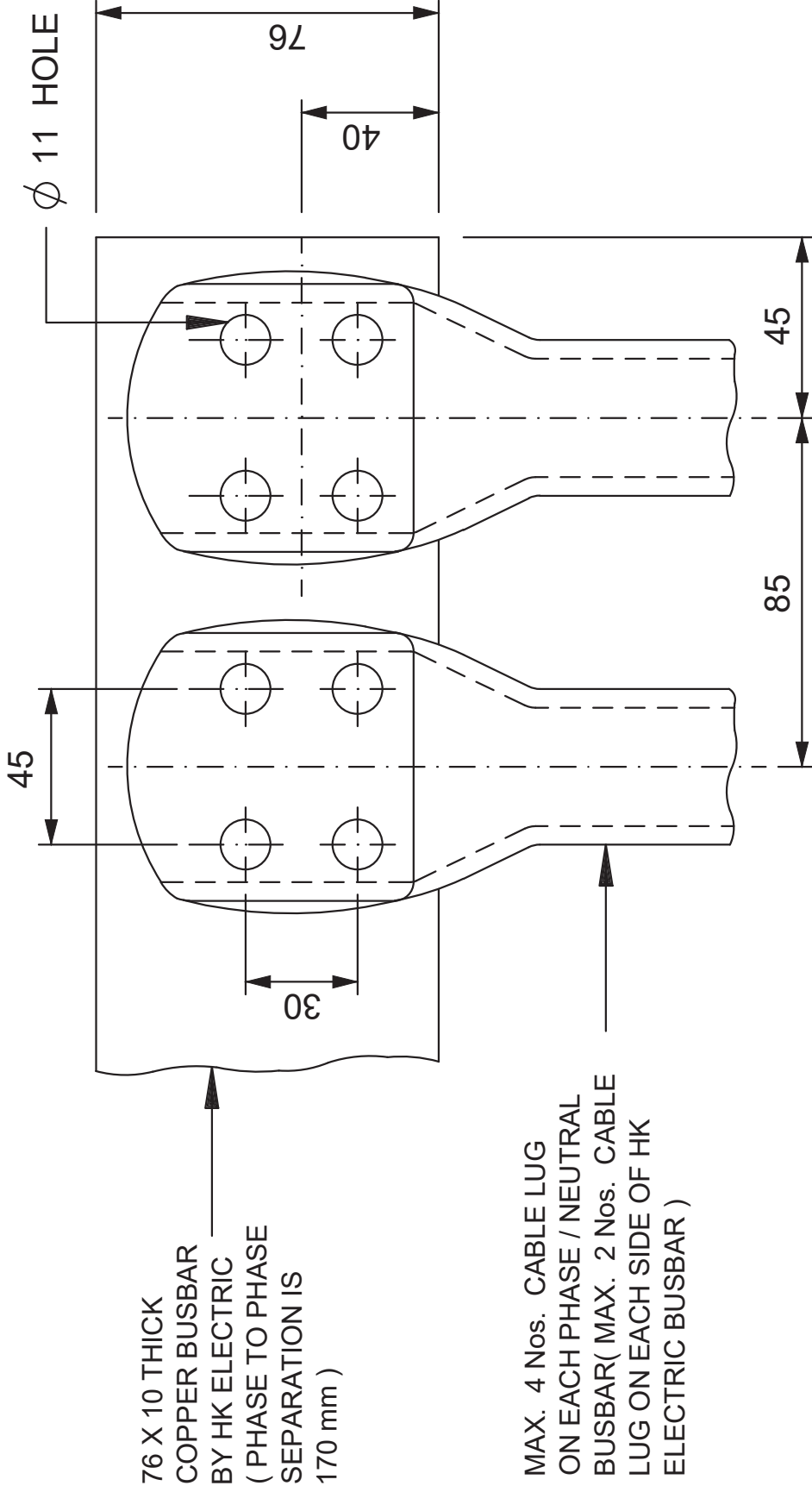

GENERAL LAYOUT FOR EACH PHASE/NEUTRAL

NOTE : ALL DIMENSIONS ARE IN mm.

Drg. No. GCS/3/17

**ARRANGEMENT FOR SINGLE-CORE CABLES CONNECTED TO HK ELECTRIC SUBSTATION
(CUSTOMER MAIN SWITCH NOT EXCEEDING 2250 A) (P31/88/R-6)**

Notes for Drawing No. GCS/3/17

1. The single-core cables and accessories shall be supplied and installed by customer. The cables shall be non-metallic sheathed with an installed rating of not less than the rating of the main switch to which they are to be connected.
2. A maximum of four (4) cables per phase/neutral may be used. The neutral conductor shall be of same installed rating as the phase conductor unless otherwise agreed by HK Electric.
3. The route length of the single-core cables must not exceed twenty (20) metres. Customer is required to ensure that the routing complies fully with current FSD's regulations.
4. The installation shall comply with the HK Electric Supply Rules, the latest edition of Code of Practice for the Electricity (Wiring) Regulations and other relevant Government Ordinances and Regulations.
5. Customer shall be responsible for providing and installing cable support facilities for his single-core cables inside HK Electric substation. Full details of the proposed method of installation must be submitted for HK Electric reference prior to installation work.
6. Customer shall be responsible for designing and installing single-core cables in order to minimize the electromagnetic interference generated from single-core cables. The physical layout of single-core cables must be submitted for HK Electric consideration prior to installation work.
7. For the purpose of compliance with Code 11 and 12 in the latest edition of Code of Practice for the Electricity (Wiring) Regulations, the customer shall use a single-core cable to be terminated in a lug with centre hole of diameter 11 mm for bonding his main earthing terminal to HK Electric bonding terminal that connects to the earthed point of transformer. Customer's bonding conductor shall not be less than 150 mm² copper equivalent.
8. Each single-core cable for phase/neutral connection shall be terminated in a lug as indicated in this drawing for connection to HK Electric equipment. The necessary bolts, nuts, washer, spring washer and penetrox grease (if necessary) shall be supplied by customer.

Notes for Drawing No. GCS/3/17

9. Durable and legible vinyl phase identification labels (such as cable ties, PVC sleeves, PVC ferrule tubes etc.) marked in L1, L2, L3 and N with character size not less than 25 mm shall be provided at the cable ends terminated to HK Electric substation. PVC insulation tape of width not less than 25 mm conforming to BSEN 60454 with phase coding L1, L2, L3 and N could also be used.
10. Termination work of the cable lugs onto HK Electric equipment shall be done by customer's registered electrical worker and under the supervision of HK Electric engineer.

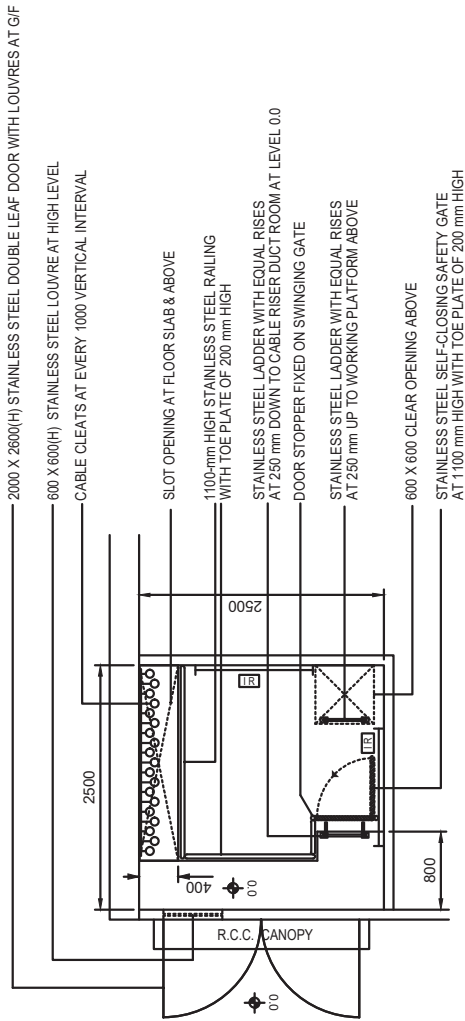

PLAN OF TYPICAL WORKING PLATFORM

NOTES :

1. CABLE SHAFT/CABLE COMPARTMENT SHALL BE NOT LESS THAN 2.5 m(L) X 2.5 m(W)
2. AROUND ALL OPEN SIDES OF THE WORKING PLATFORM (UNLESS OTHERWISE SPECIFIED) SHALL BE INSTALLED WITH FIXED PROTECTIVE BARRIERS IN 1100 mm HIGH & TOE PLATES OF 200 mm HIGH. SHARP EDGES OF FIXING RAILS SHALL BE FITTED WITH PROTECTIVE END CAPS TO GUARD AGAINST PERSONAL INJURY.
3. THE VERTICAL LADDERS SHALL NOT BE FIXED SOLELY BY THEIR OWN WEIGHT.
4. THE FLOOR OF WORKING PLATFORM AND RUGS OF LADDER SHALL BE SLIP RESISTANT.
5. THE SELF-CLOSING SAFETY GATE SHALL BE UNDER A SLOW CLOSING OPERATION AND SHALL BE DESIGNED TO SWING ONLY INTO THE ACCESS HOLE. NO HOLD-OPEN OR HOLD-CLOSE DEVICES SHALL BE FITTED.
6. LIGHTINGS AND 13-A SOCKET OUTLETS IN THE CABLE SHAFT / COMPARTMENT SHALL BE PROVIDED. DETAILS WILL BE SPECIFIED IN THE SUBSTATION LAYOUT DRAWING.
7. AN EARTHING TAPE OR EQUIVALENT SHOULD BE PROVIDED AND INSTALLED BY THE DEVELOPER FROM THE EARTHING TERMINAL OF THE SUBSTATION DOWN TO THE BOTTOM OF THE CABLE SHAFT FOR BONDING ALL THE METAL PARTS INSIDE THE CABLE SHAFT.
8. PLEASE REFER TO SUBSTATION DRAWING FOR THE NUMBER OF CABLE CLEATS TO BE INSTALLED IN THE CABLE SHAFT.
9. TWO CABLE SHAFTS/COMPARTMENTS OR ONE CABLE SHAFT/COMPARTMENT WITH TWO CABLE ENTRY POINTS OF MINIMUM 3500 mm APART SHOULD BE PROVIDED.
10. FOR INSTALLATION OF CABLE CLEATS, PLEASE REFER TO DRAWING No. P67/108/R-3. THE DEVELOPER SHOULD BE RESPONSIBLE FOR TEMPORARY REMOVAL OF THE CABLE CLEATS FOR HK ELECTRIC CABLE INSTALLATION FOR SUBSTATION COMMISSIONING AND RE-INSTALLING THE CABLE CLEATS AFTER HK ELECTRIC CABLE LAYING, IF SO REQUIRED BY HK ELECTRIC DURING THE COURSE OF THEIR CABLING WORK.
11. UNLESS OTHERWISE SPECIFIED, THE CODE OF PRACTICE FOR DESIGN OF PLATFORMS, ETC. IN BS 5395 ; PART 3 SHALL BE FOLLOWED.
12. ENGRAVED WARNING LABELS WITH EACH CHARACTER OR LETTER NOT LESS THAN 15 mm HIGH IN WHITE ON RED BACKGROUND SHALL BE FIXED TO EACH VERTICAL LADDER AND WORKING PLATFORM.

* THE RINGS OF LADDER IS DESIGNED WITH A CONCENTRATED LOAD OF 1.5 KN TO BS5395 ; PART 3.
 按 BS5395 ; PART 3 設計，梯級可承受 1.5 KN 的集中負載。為安全起見，暨梯每次只限一人使用。

** THE WORKING PLATFORM IS DESIGNED WITH UNIFORMLY DISTRIBUTED LOAD IN 5 KPa AND A CONCENTRATED LOAD OF 1.0 KN TO BS5395 ; PART 3 FOR GENERAL DUTY USE.
 按 BS5395 ; PART 3 設計，工作平台一般用途而其平均承載量為 5 KPa 及可承受 1.0 KN 的集中負載。為安全起見，每一工作平台最多容納四人。

13. BEFORE HANDING OVER THE FIRST LEVEL SUBSTATION, THE ARCHITECT MUST SUBMIT A CERTIFICATE INDICATING THAT THE WORKING PLATFORM TOGETHER WITH THE LADDERS IS DESIGNED AND CONSTRUCTED TO REQUIREMENTS AS MENTIONED IN ABOVE NOTE Nos. 11-12 FOR HK ELECTRIC RECORD.

Dr. GCS/3/18

TYPICAL DESIGN OF WORKING PLATFORM AT

CABLE SHAFT/CABLE COMPARTMENT FOR FIRST LEVEL SUBSTATION (P605/04/R-4)

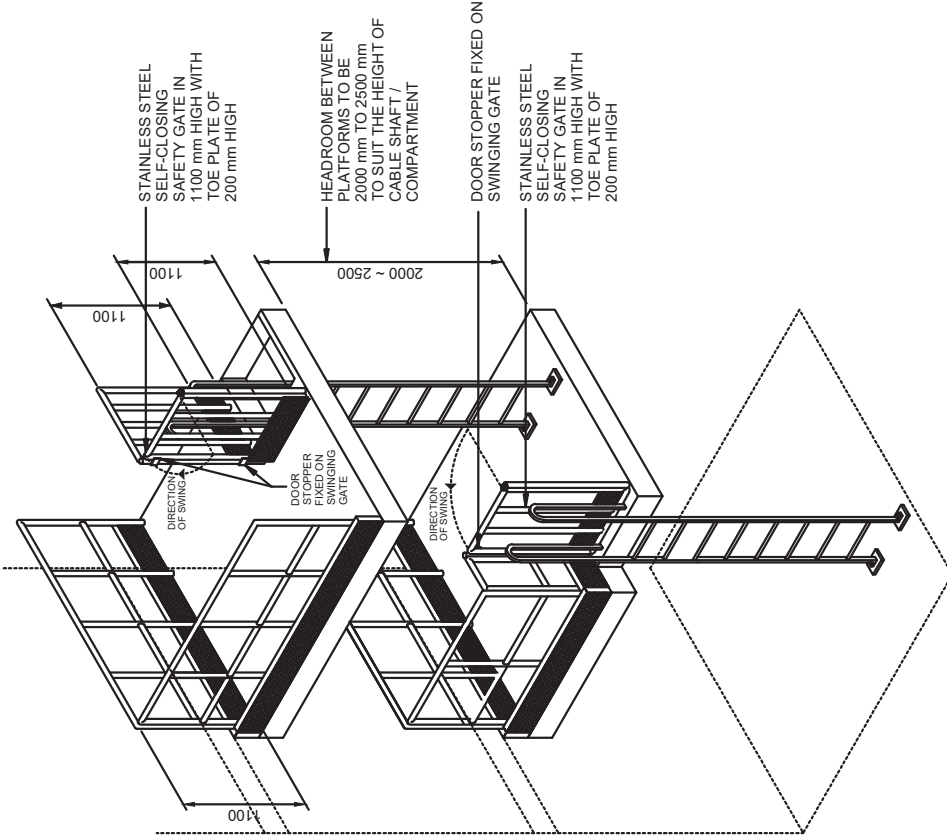

TYPICAL WORKING PLATFORMS

NOTE :

HDGS = HOT DIP GALVANISED STEEL
 ALL DIMENSIONS ARE IN mm.

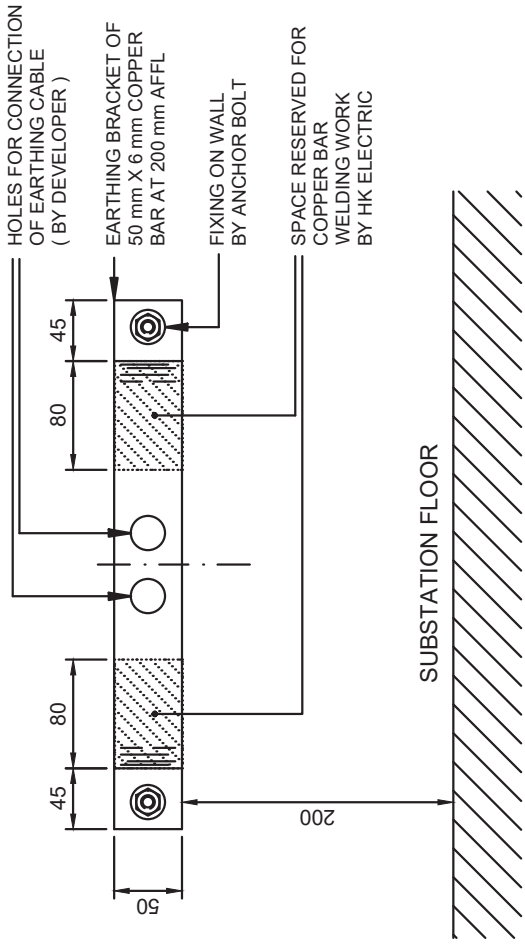

ELEVATION

AFFL = ABOVE FINISHED FLOOR LEVEL

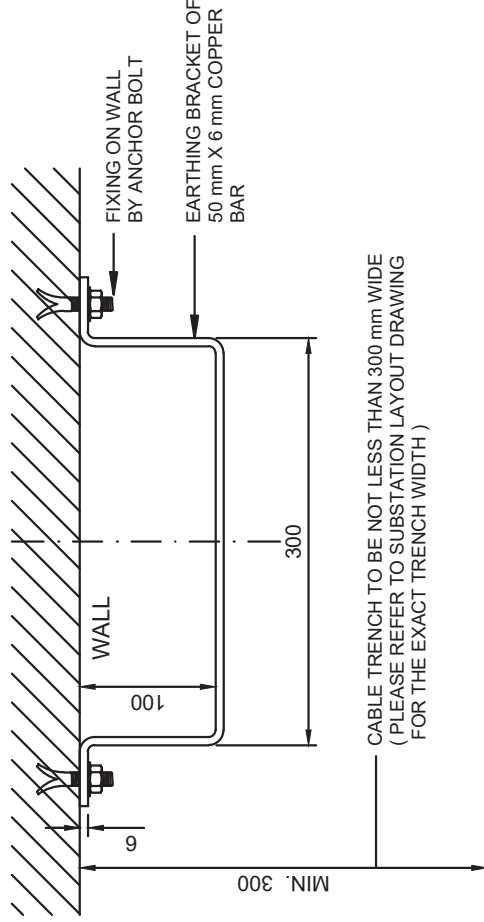

REQUIREMENT :

1. THE BUILDING MAIN EARTHING SHALL BE BONDED TO THE FOUNDATION OF BUILDING AND EARTHING PIT WITH EARTHING RODS. THE MEASURED EARTH LOOP RESISTANCE SHALL NOT EXCEED 0.5 OHM.
2. THE EARTHING SYSTEM SHALL BE DESIGNED AND CONSTRUCTED TO BS 7430 OR EQUIVALENT, UNLESS OTHERWISE SPECIFIED IN CODE OF PRACTICE FOR THE ELECTRICITY (WIRING) REGULATIONS.

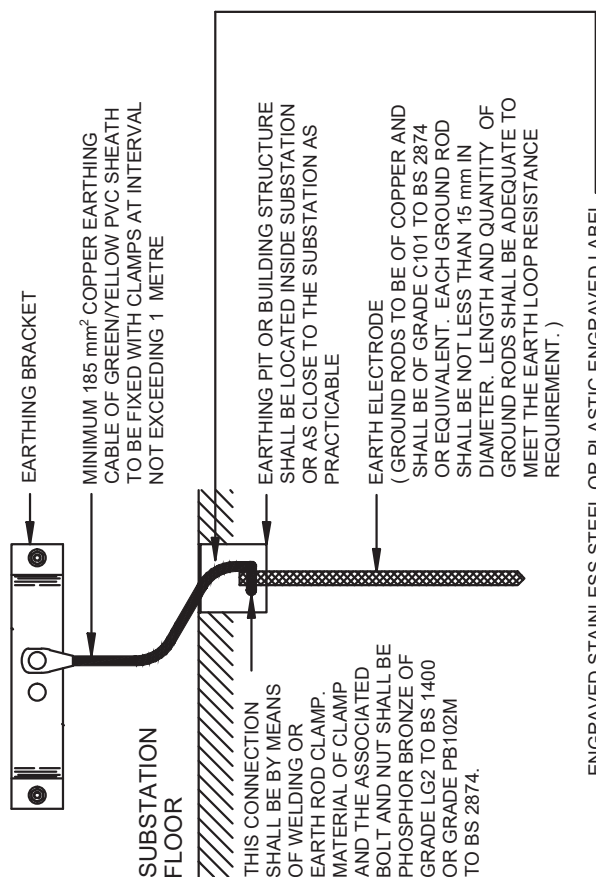

NOTE :

1. TYPICALLY, THE EARTHING BRACKET WILL BE DESIGNED TO BE AT THE SUBSTATION CABLE ENTRY OF TRANSFORMER COMPARTMENT. PLEASE REFER TO SUBSTATION LAYOUT DRAWING FOR THE EXACT POSITION.
2. ALL DIMENSIONS ARE IN mm.

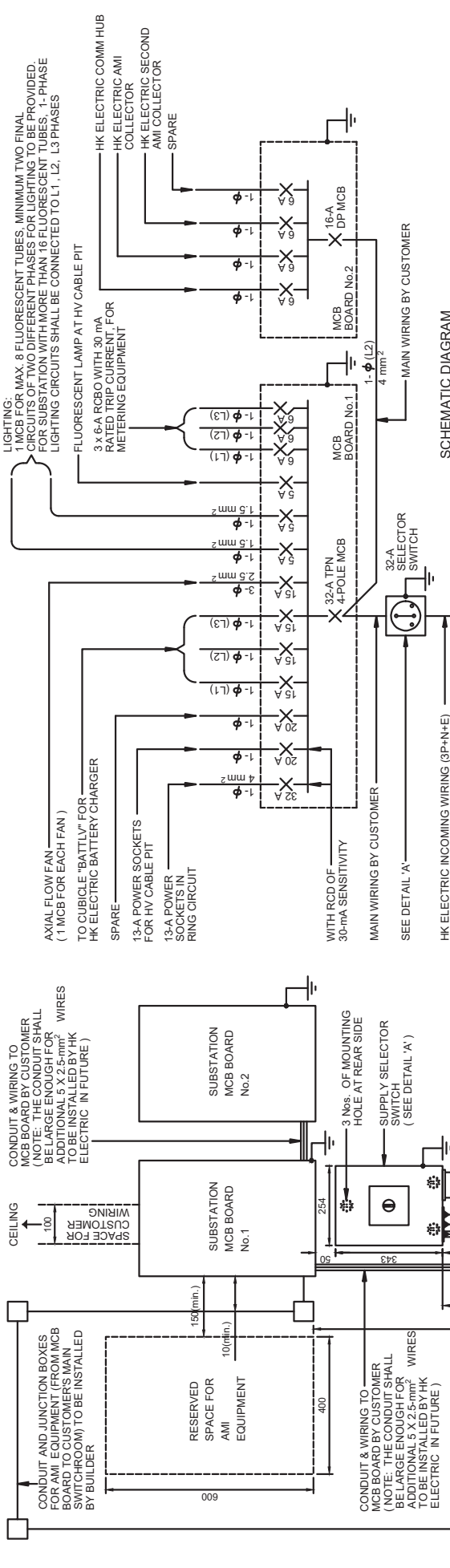

SCHEMATIC DIAGRAM

NOTES:

- THE SELECTOR SWITCH SHALL BE ARRANGED AS FOLLOWS:
 - 1.1. ALL OF 32-A TERN SELECTOR SWITCH TO BE SUPPLIED BY HK ELECTRIC FOR SUBSTATION POWER SUPPLY PURPOSE SHALL BE COLLECTED BY CUSTOMER AND INSTALLED AT SITE BY CUSTOMER.
 - 1.2. CUSTOMER SHALL FIT 4 Nos. 6mm² 1.6 CU/PVC WIRINGS AT TERMINALS C2, C4, C6 & C8. TERMINAL CONNECTION SHALL BE BY MEANS OF CRIMPED RING TYPE LUGS.
 - 1.3. CASING OF SELECTOR SWITCH SHALL BE BONDED TO THE SUBSTATION ELECTRICAL CONDUIT SYSTEM. CUSTOMER SHALL ENSURE THAT THE EARTHING CONNECTION FOR THE SELECTOR SWITCH COMPLETES FULLY WITH HK ELECTRIC SUPPLY RULES AND CODE OF PRACTICE FOR THE ELECTRICITY (WIRING) REGULATIONS.
 - 1.4. WITH SELECTOR SWITCH SHALL BE MOUNTED ON WALL BY ANCHOR BOLTS (INCLUDING WASHERS AND NUTS) WITH UNISTRUT AT THE BACK. BOTTOM OF THE SELECTOR SWITCH SHALL BE AT 1000 mm ABOVE FINISHED FLOOR LEVEL. THE RUBBER BUNG SHALL ONLY BE VIA THE TOP OF THE SELECTOR SWITCH. CUSTOMER WIRINGS SHALL ONLY BE VIA THE TOP OF THE MAIN MCB BOARD.
- THE CUBICLE "BATTLV" SHALL BE SUPPLIED AND INSTALLED BY CUSTOMER.
- ALL MCB USED IN MCB BOARD No.1 SHALL HAVE A BREAKING CAPACITY OF NOT LESS THAN 9 KA.
- MCB BOARD No.2 SHALL COMPLY WITH THE FOLLOWING REQUIREMENTS:
 - 4.1. ALL MCB USED SHALL HAVE A BREAKING CAPACITY OF NOT LESS THAN 9 KA.
 - 4.2. THE 6-A DOUBLE POLE MCB SHALL BE OF TRIPPING CHARACTERISTIC B.
 - 4.3. THE 16-A DOUBLE POLE MCB SHALL BE OF TRIPPING CHARACTERISTIC C.
 - 4.4. THE 24mm (Ø) X 102mm (H) ENGRAVED LABEL WITH RED CHARACTERS ON WHITE BACKGROUND AS SHOWN BELOW SHALL BE FIXED ON THE COVER OF MCB BOARD No.2.

Communication Hub and AMI Equipment Power Distribution Board
 通訊樞紐及智能電錶基礎設施配電箱

DO NOT DISTURB
請勿干擾

Unauthorised operation is prohibited
未經授權，不得操作配電箱

For enquiries, please contact: 28 14 3456 (Office hour 辦公時間) 25 10 2004 (Outside office hour 非辦公時間)
如有查詢，請致電：

- ALL THE MCB BOARDS, CUBICLE "BATTLV" AND 32-A SELECTOR SWITCH SHALL BE MOUNTED ON SUBSTATION WALL BY USING UNISTRUT CHANNELS AT THE BACK. PLEASE REFER TO THE SUBSTATION LAYOUT DRAWING FOR THE EXACT POSITIONS OF THE MCB BOARDS AND CUBICLE "BATTLV".
- ALL DIMENSIONS ARE IN mm.

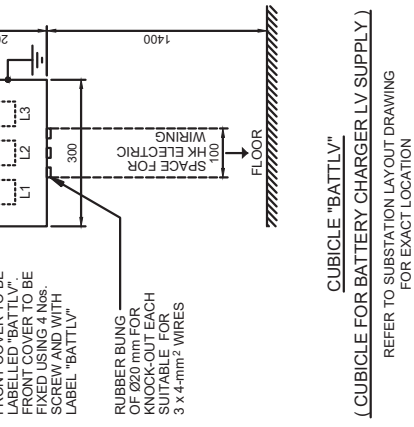
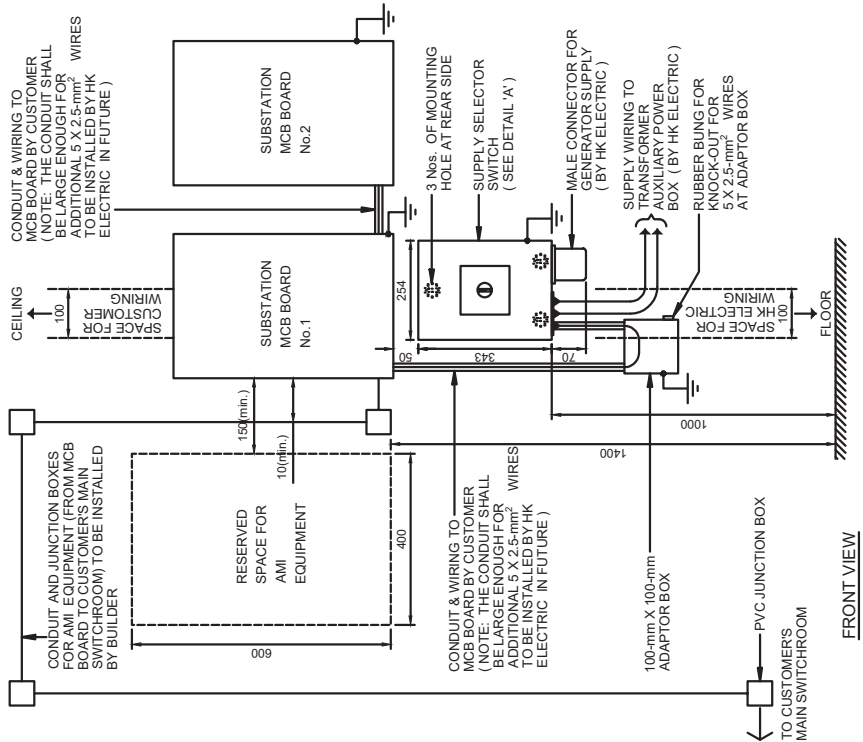

Dr. No. GCS/3/20

SUBSTATION MAIN SUPPLY & SCHEMATIC DIAGRAM (P561/01/R-10)

- 1) UPVC PIPE , DUCT SPACER , SOCKET & END CAP FOR $\phi 150$ -mm DUCTS/SLEEVES WILL BE PROVIDED BY HK ELECTRIC AND COLLECTED BY THE DEVELOPER. THE NOMINAL LENGTH OF THE UPVC PIPE IS 4 m AND THE DEVELOPER SHALL CUT THE PIPE TO THE REQUIRED LENGTH.
- 2) UPVC PIPE , SOCKET & END CAP FOR $\phi 75$ -mm DUCTS/SLEEVES WILL BE PROVIDED BY HK ELECTRIC AND COLLECTED BY THE DEVELOPER. THE NOMINAL LENGTH OF THE UPVC PIPE IS 4 m AND THE DEVELOPER SHALL CUT THE PIPE TO THE REQUIRED LENGTH.
- 3) THE MINIMUM SPACING AMONG CABLE ENTRY DUCTS AND BUILDING STRUCTURE , SUCH AS WALLS , COLUMNS , BEAMS , PILING CAPS ETC. FOR A TYPICAL ARRANGEMENT OF DUCTS IN SUBSTATION CABLE ENTRY AS SHOWN BELOW SHALL BE FOLLOWED.

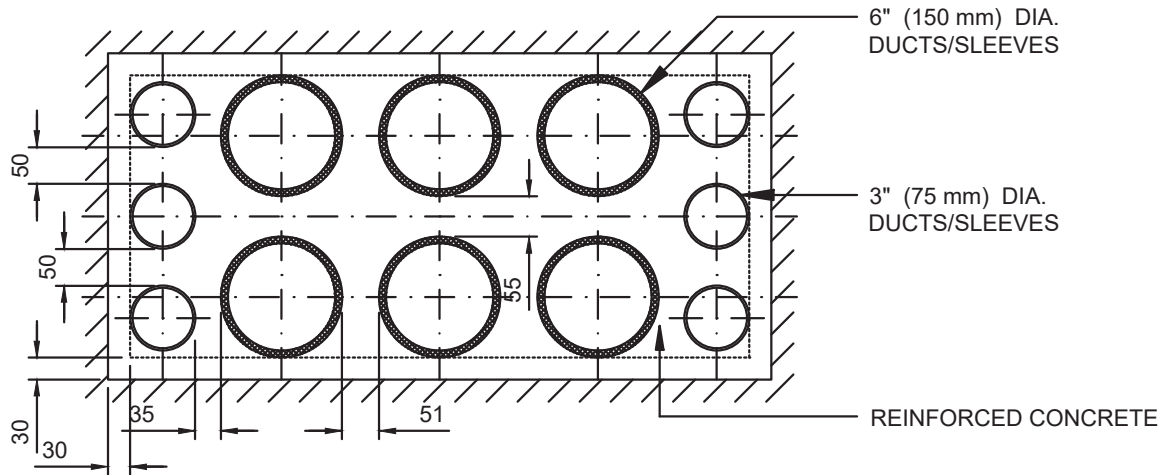

6 X $\phi 150$ -mm DUCTS IN 2 LAYERS + 6 X $\phi 75$ -mm DUCTS AT BOTH SIDES

- 4) DUCT SPACERS FOR $\phi 150$ -mm DUCTS/SLEEVES SHALL BE INSTALLED AT BOTH ENDS OF THE PRE-CAST CABLE ENTRY DUCT BANK

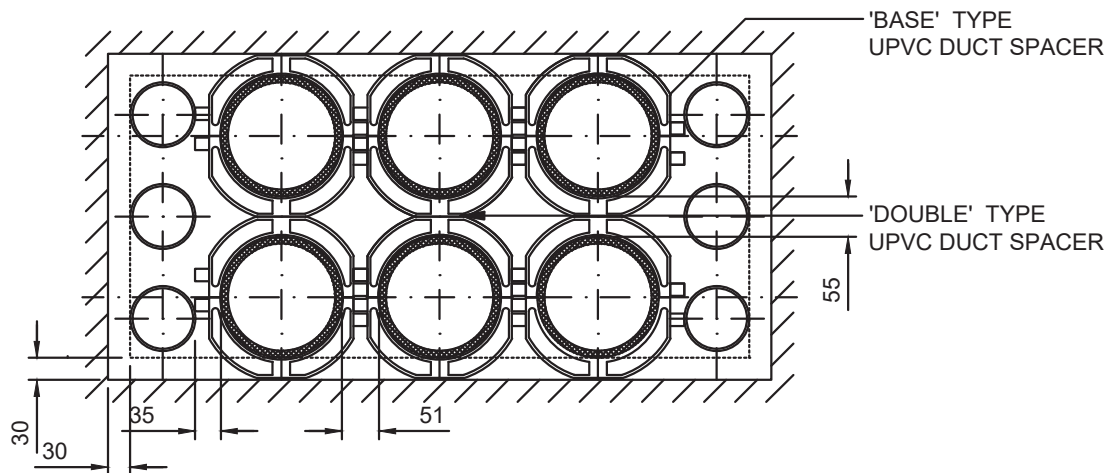

ASSEMBLY OF UPVC DUCTS & UPVC DUCT SPACERS

- 5) THE CABLE ENTRY OF SUBSTATION SHALL BE PROPERLY SEALED AND WATER-PROOFED AGAINST INGRESS OF WATER BY DEVELOPER.

NOTE : ALL DIMENSIONS ARE IN mm.

Drg. No. GCS/3/21
**TYPICAL ARRANGEMENT OF CABLE ENTRY DUCTS IN
 SUBSTATION (P627/05/R-1) SHEET 1 OF 2**

- 6) CONSTRUCTION OF PRE-CAST DUCT BANK SHALL BE IN GENERAL IN ACCORDANCE WITH THE FOLLOWING :

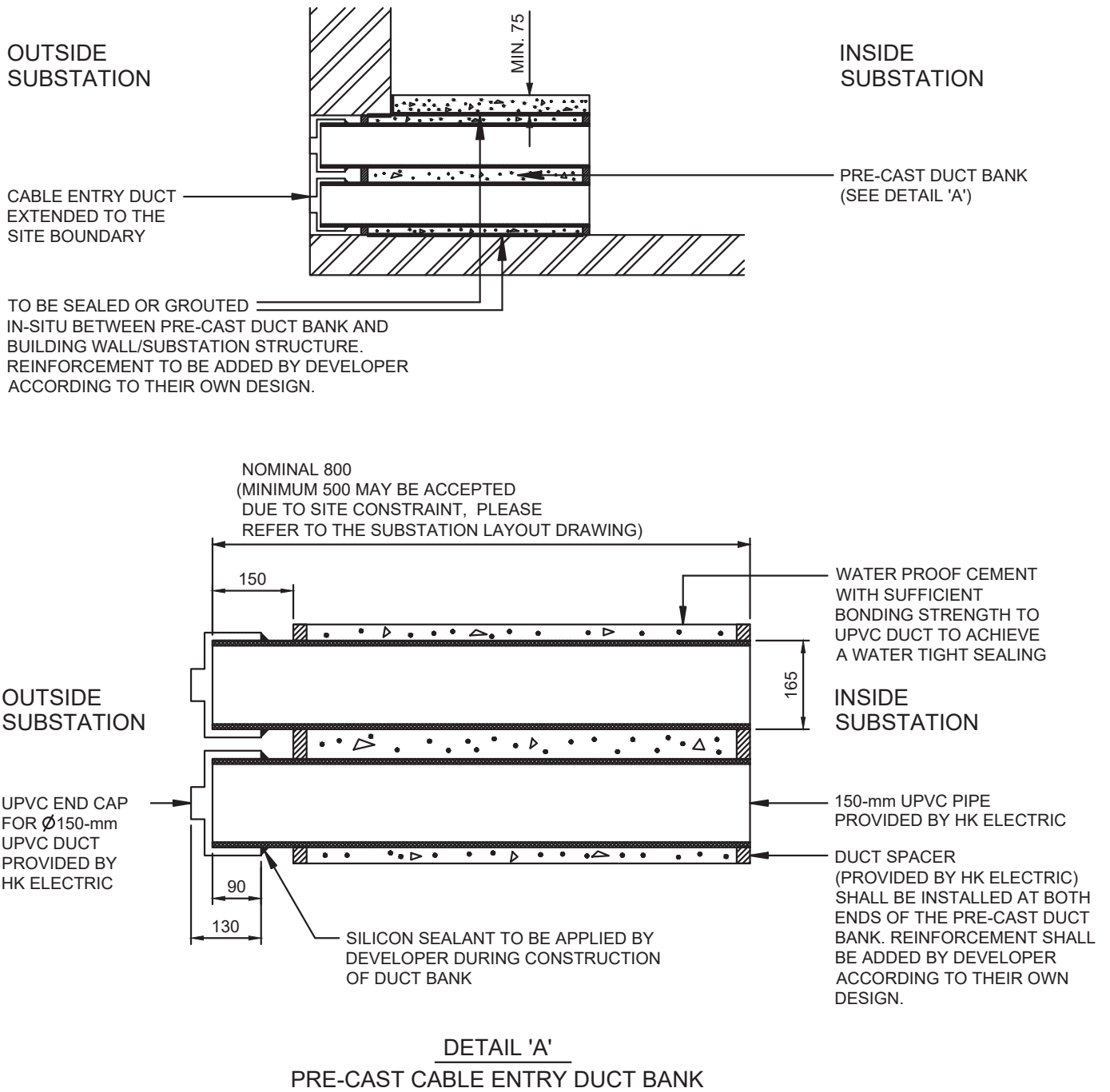

NOTE : ALL DIMENSIONS ARE IN mm.

Drg. No. GCS/3/21
**TYPICAL ARRANGEMENT OF CABLE ENTRY DUCTS IN
 SUBSTATION (P627/05/R-1) SHEET 2 OF 2**

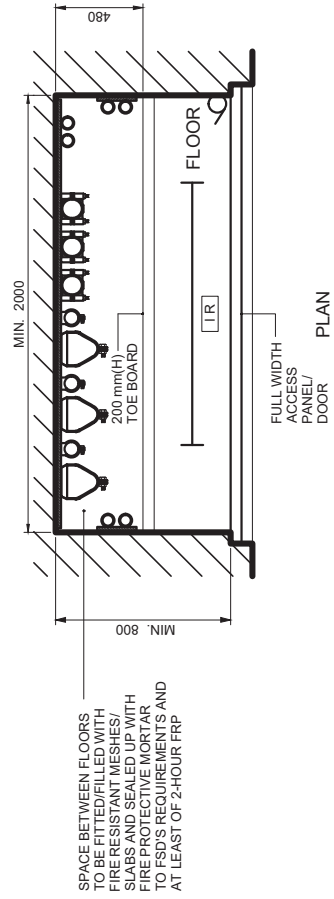
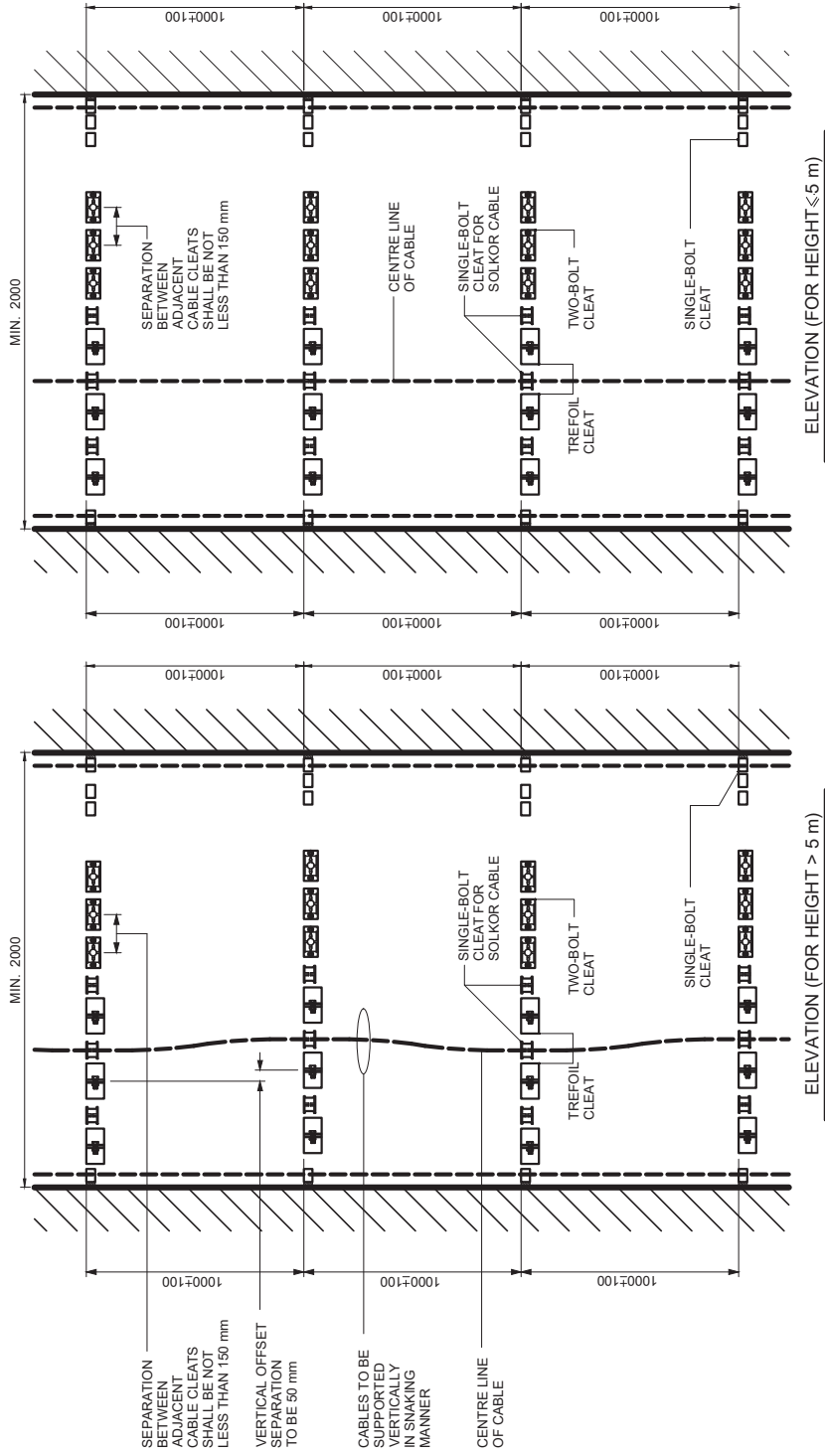

NOTE : ALL DIMENSIONS ARE IN mm.

Dr. No. GCS/3/22

**TYPICAL ARRANGEMENT OF CABLES AND CABLE CLEATS
IN RISER DUCT (VERTICAL HEIGHT \leq 7 METRES)**
(P671/08/R-3) SHEET 1 OF 2

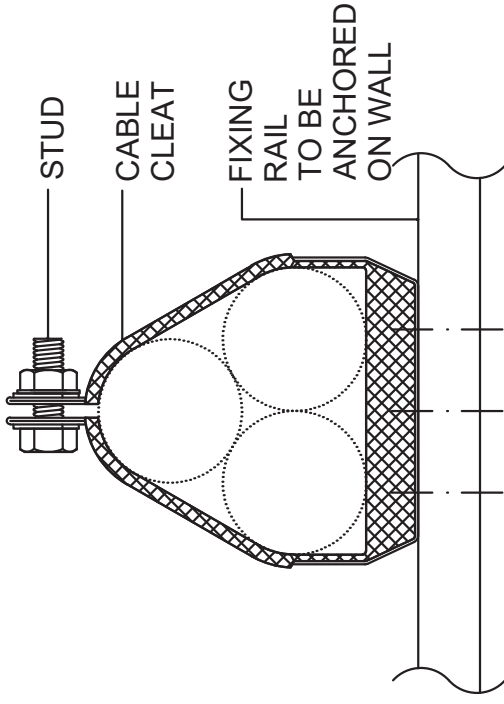

TYPICAL DESIGN OF SINGLE-BOLT CLEAT

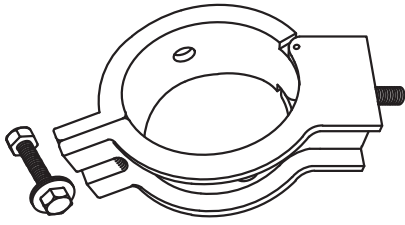

RUBBER PAD
(2 Nos.)

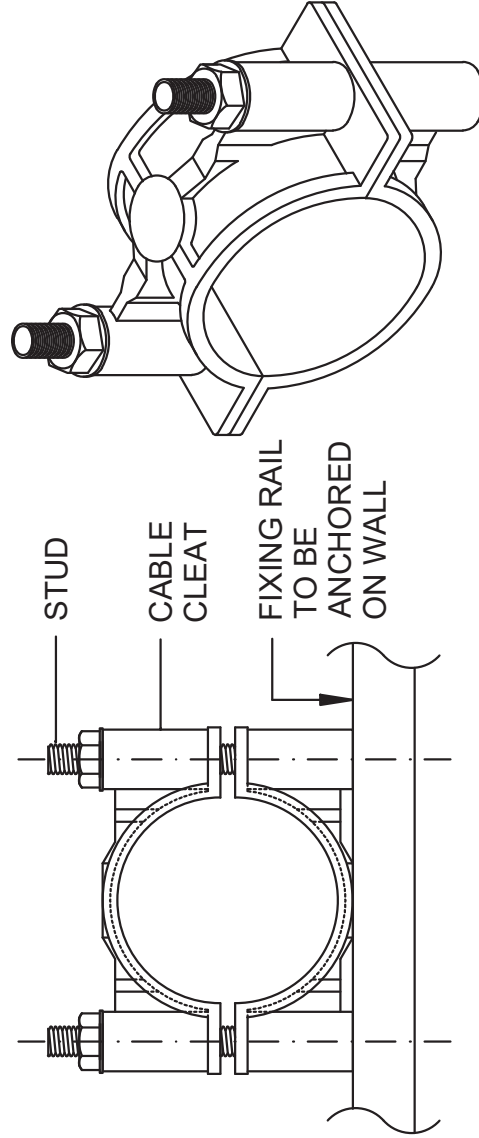

TYPICAL DESIGN OF TWO-BOLT CLEAT

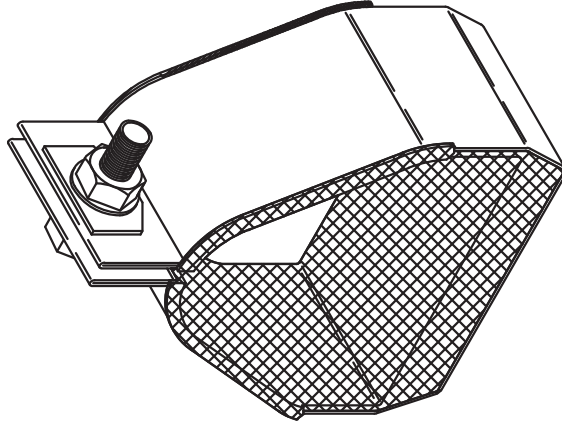

TYPICAL DESIGN OF TREFOIL CLEAT

Drg. No. GCS/3/22

TYPICAL ARRANGEMENT OF CABLES AND CABLE CLEATS
IN RISER DUCT (VERTICAL HEIGHT \leq 7 METRES)

(P671/08/R-3) SHEET 2 OF 2

Notes for Drawing No. GCS/3/22

1. Customer is required to provide the appropriate type and size of cable cleat to suit the following cables to be installed in riser duct. Exact type of cables to be used will be specified in the substation layout drawing.
2. The developer should be responsible for temporary removal of the cable cleats for HK Electric cable installation for substation commissioning and re-installing the cable cleats after HK Electric cable laying, if so required by HK Electric during the course of their cabling work.
3. External diameters of HK Electric cables are:

Designated code of cable	Cable description	Size	Type of cable cleat to be used
T-2	HV 300-mm ² 3/C Cu cable	101±3 mm	Two-bolt cleat
T-4	HV 300-mm ² 1/C SUSWA Cu cable	53±3 mm	Trefoil cleat
R-3	HV 240-mm ² 3/C Cu cable	91±3 mm	Two-bolt cleat
G-1	LV 300-mm ² 4/C AL cable	73±3 mm	Two-bolt cleat
P-1	Telephone / pilot cable	32±3 mm	Single-bolt cleat
Y-1	Earthing cable	25±3 mm	Single-bolt cleat
S-1	Solkor cable	38±3 mm	Single-bolt cleat

(The designated code of cable will be applied and quoted in the substation layout drawing for reference)

4. Weight of each LV power cable shall be taken as 15 kgf per metre, where weight of each HV 3/C cable or each set of HV 3 x 1/C cable should be taken as 20 kgf per metre.
5. Material of cable cleat and the associated bolts, nuts, washers and spring washers, etc. to be aluminium alloy, other metals or alloy with corrosion resistant coating / plating. Cable cleats of non-metallic material will NOT be accepted.
6. Each trefoil cleat and two-bolt cable cleat shall be type tested to withstand a vertical safe working load (SWL) of not less than 15 times the 1 metre length of the cable to be cleated.

Notes for Drawing No. GCS/3/22

7. Design operating temperature of cable cleat shall be from 0°C to 85°C.
8. The cable cleats shall be mounted on suitable fixings. The stud size for trefoil cable cleat and two-bolt cable cleat shall be not less than M12. Rubber pad as a supplementary mat for securing the cable shall be provided for each cable cleat.
9. The horizontal fixing rail shall be of hot dip galvanised steel or other corrosion resistant material and be designed and constructed to withstand a vertical SWL of the higher value of (a) or (b) below.
 - a. 1000 kgf.
 - b. n times 200 kgf where n is the total number of cleats on the same fixing rail.
10. A clear working space of not less than 900 mm should be provided in front of the cable cleats.
11. Customer is required to submit catalogues and/or samples of cable cleats for approval.

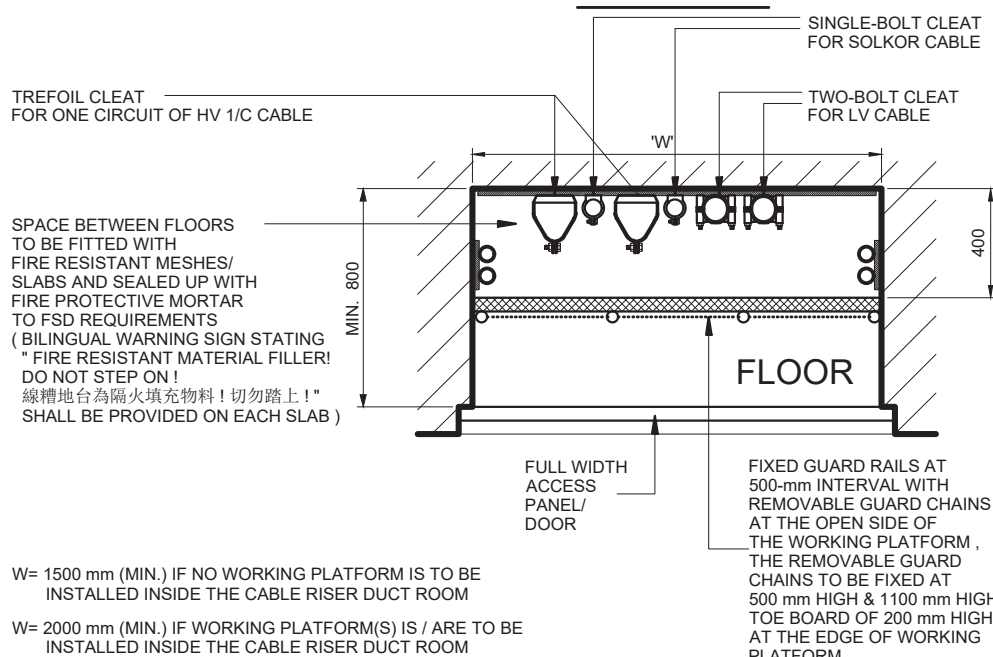
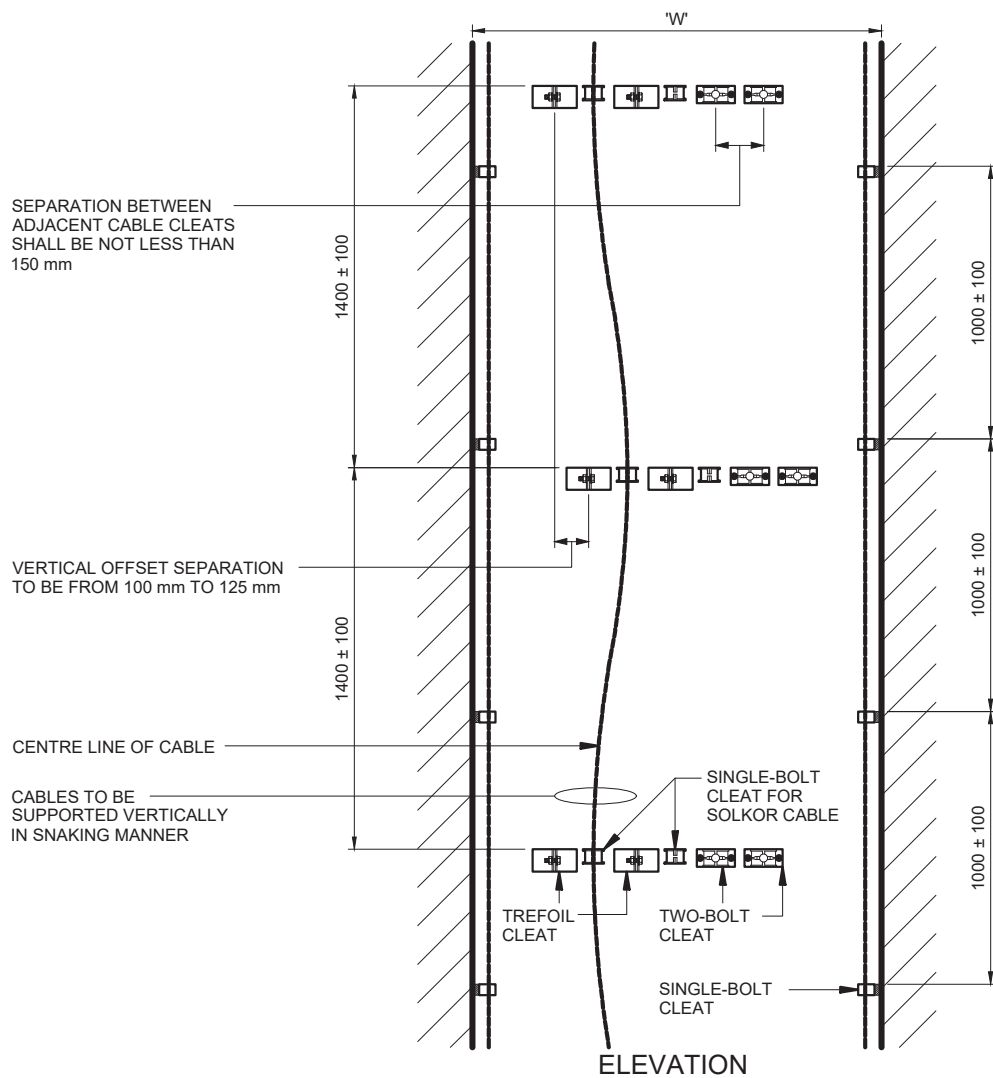

NOTE : ALL DIMENSIONS ARE IN mm.

Drg. No. GCS/3/23

TYPICAL ARRANGEMENT OF CABLES AND CABLE CLEATS

IN RISER DUCT FOR UPPER FLOOR SUBSTATION OR BASEMENT

SUBSTATION WITH LEVEL DIFFERENCE EXCEEDING 7 METRES

(P666/08/R-4) SHEET 1 OF 2

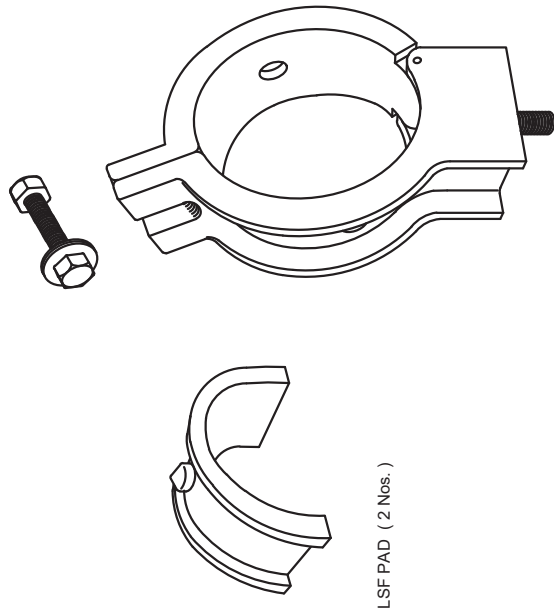

TYPICAL DESIGN OF SINGLE-BOLT CLEAT

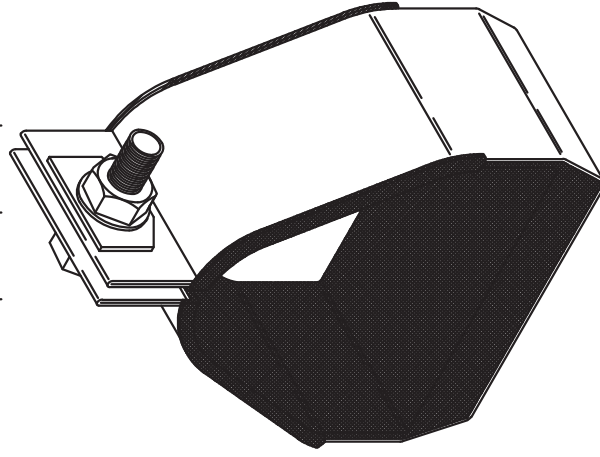
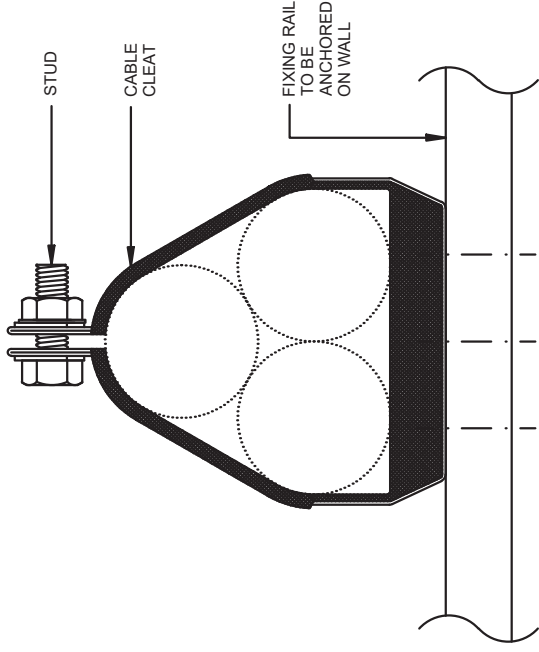

TYPICAL DESIGN OF TREFOIL CLEAT

(NON-METALLIC PARTS TO BE LSF)

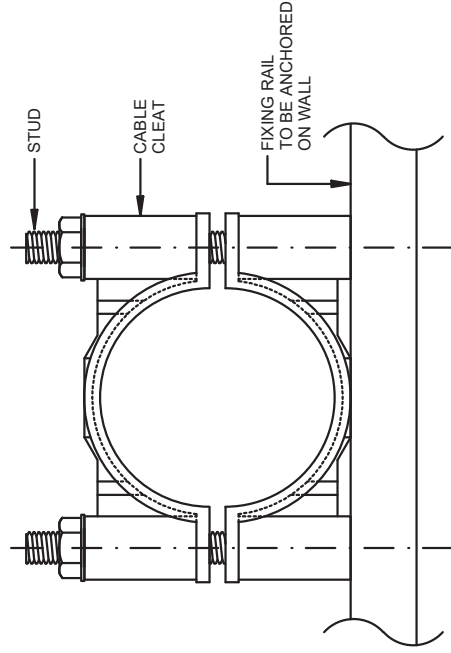
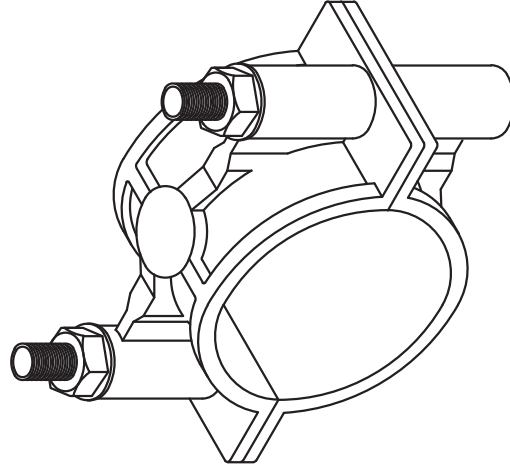

TYPICAL DESIGN OF TWO-BOLT CLEAT

(NON-METALLIC PARTS TO BE LSF)

Drg. No. GCS/3/23

**TYPICAL ARRANGEMENT OF CABLES AND CABLE CLEATS
IN RISER DUCT FOR UPPER FLOOR SUBSTATION OR BASEMENT SUBSTATION
WITH LEVEL DIFFERENCE EXCEEDING 7 METRES (P666/08/R-4) SHEET 2 OF 2**

Notes for Drawing No. GCS/3/23

1. Customer is required to provide the appropriate type and size of cable cleat to suit the following cables to be installed in riser duct. Exact type of cables to be used will be specified in the substation layout drawing.
2. The developer should be responsible for temporary removal of the cable cleats for HK Electric cable installation for substation commissioning and re-installing the cable cleats after HK Electric cable laying, if so required by HK Electric during the course of their cabling work.
3. External diameters of HK Electric cables are:

Designated code of cable	Cable description	Size	Type of cable cleat to be used
T-3	HV 300-mm ² 1/C Cu LSF cable	50±3 mm	Trefoil cleat
R-2	HV 240-mm ² 3/C Cu LSF cable	81±3 mm	Two-bolt cleat
G-2	LV 300-mm ² 4/C AL LSF cable	73±3 mm	Two-bolt cleat
S-2	LSF Solkor cable	38±3 mm	Single-bolt cleat
P-2	Telephone/Pilot LSF cable	32±3 mm	Single-bolt cleat
Y-2	Earthing LSF cable	25±3 mm	Single-bolt cleat

(The designated code of cable will be applied and quoted in the substation layout drawing for reference)

4. Material of cable cleat and the associated bolts, nuts, washers and spring washers, etc. should be of aluminium alloy, other metals or alloy with corrosion resistant coating / plating. Cable cleats of non-metallic material will NOT be accepted.
5. Each trefoil cleat and two-bolt cleat shall be type tested to withstand a vertical safe working load (SWL) of not less than 15 times the 1.4 metre length of the cable to be cleated. Each single-bolt cleat shall be type tested to withstand a vertical SWL of not less than 15 times of the cable to be cleated which should be taken as 4 kgf per metre.
6. Weight of each LV power cable shall be taken as 15 kgf per metre, where weight of each HV 3/C power cable or each set of HV 3 x 1/C power cable shall be taken as 20 kgf per metre.

Notes for Drawing No. GCS/3/23

7. The horizontal fixing rail shall be of hot dip galvanised steel or other corrosion resistant material and be designed and constructed to withstand a vertical SWL of the higher value of (a) or (b) below.
 - a. 1000 kgf.
 - b. n times 200 kgf where n is the total number of cleats on the same fixing rail.
8. The cable cleats shall be mounted on suitable fixings. The stud size for trefoil cleat and two-bolt cleat shall be not less than M12. LSF lining or pad as a supplementary mat for securing the cable shall be provided for each cable cleat.
9. Design operating temperature of cable cleat shall be from 0°C to 85°C.
10. Customer is required to submit catalogues and/or samples of cable cleats for approval.
11. LSF stands for low smoke fume and zero halogen to IEC, BS, UL or ASTM standards.

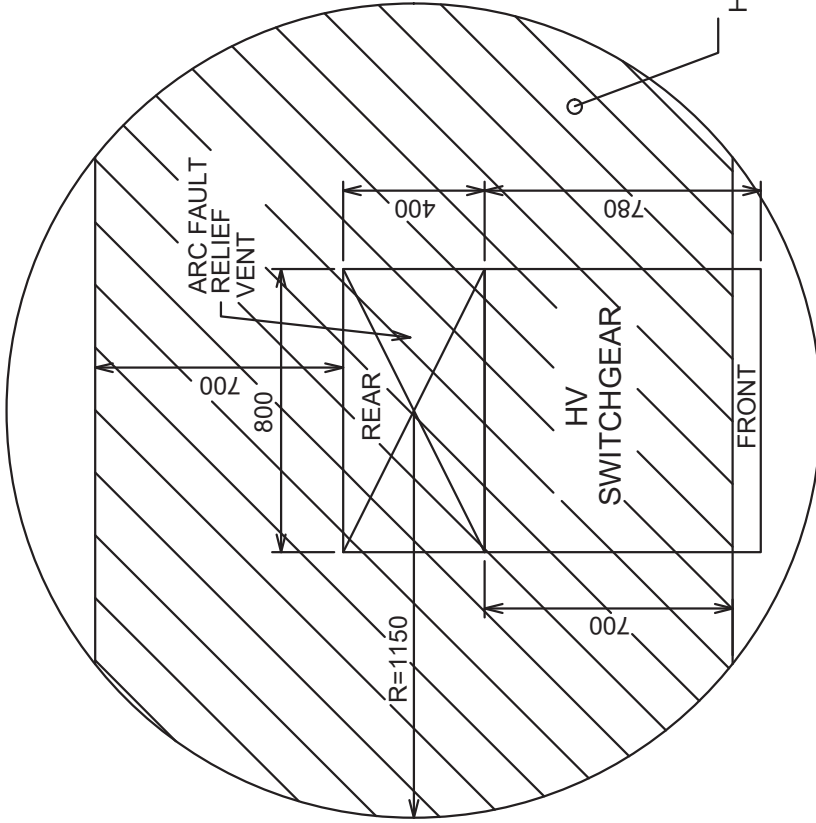
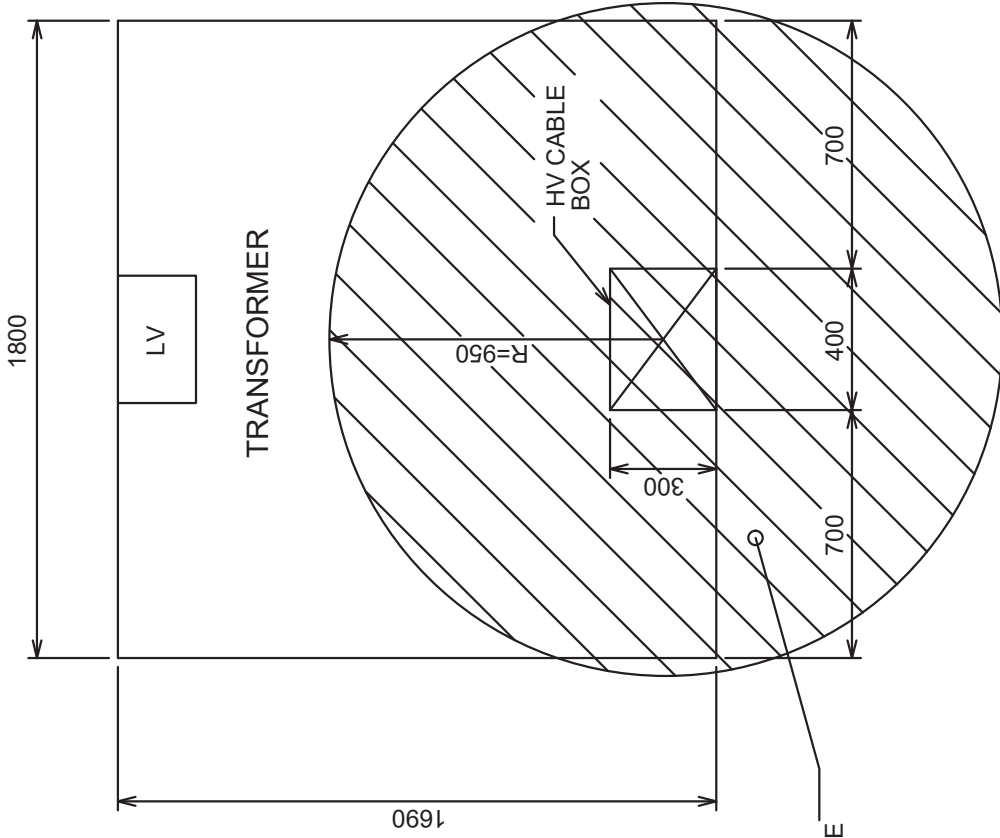

NOTES :

1. NO FLUORESCENT LAMP FITTING, EXIT LIGHT FITTING, HEAT DETECTOR, SMOKE DETECTOR, AXIAL FLOW FAN, FLEXIBLE CONDUIT FOR FAN AND EMERGENCY PUSH BUTTON FOR FAN SHALL BE INSTALLED WITHIN THE HIGH LEVEL HAZARD ZONE UNLESS THEY ARE AT LESS THAN 2300 mm HIGH WHEN MEASURED FROM SUBSTATION FLOOR.

2. ALL DIMENSIONS ARE IN mm.

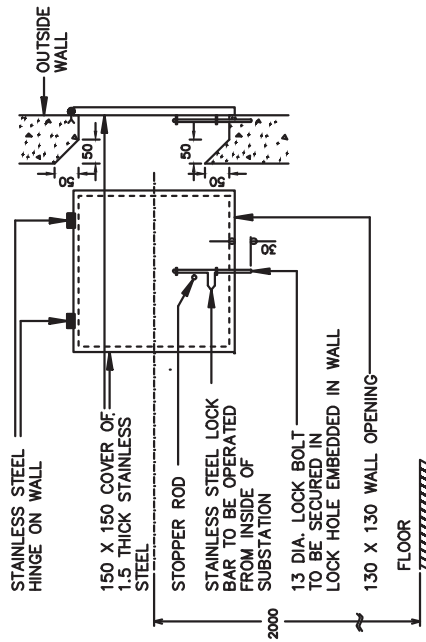
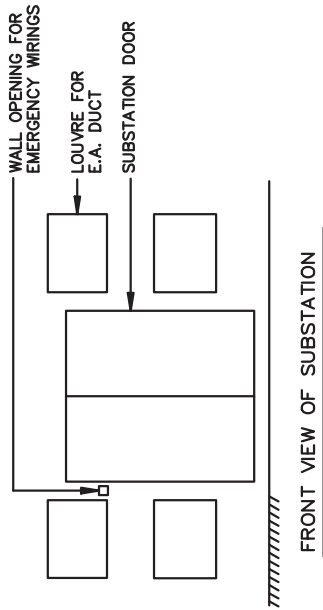

DETAILS OF WALL OPENING FOR EMERGENCY WIRINGS (ONLY FOR SUBSTATION AT GROUND LEVEL)

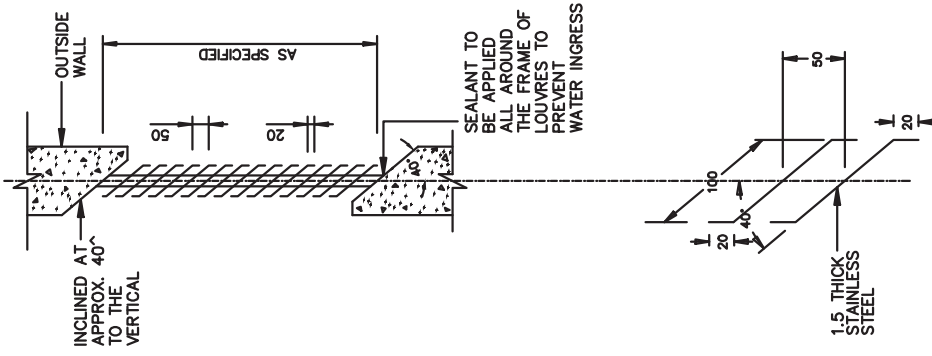

VENT. LOUVRES DETAILS

NOTES :

1. STAINLESS STEEL REFERRED IN THIS DRAWING SHALL BE OF GRADE 316.
2. LOUVRE PLATES SHALL BE ROUNDED TO AVOID LACERATION HAZARD.
3. ALL DIMENSIONS ARE IN mm.

Drg. No. GCS/3/25

SUBSTATION LOUVRES DETAILS (P638/06/R-1)

Do you know that HK Electric has to apply for an **Excavation Permit from Highways Department of HKSAR Government** before laying a cable to make electricity available to you?

Here are some facts on how HK Electric applies for the Excavation Permit, how much it costs to HK Electric and how long it will take.

Summary of amended Ordinance effective on 1st April 2004 for Excavations in Public Streets and Footpaths

- All excavations are controlled under the Land (Miscellaneous Provisions) Ordinance, Cap. 28.
- An Excavation Permit is required for excavations in unleased Government land, otherwise a fine up to \$50,000 and an imprisonment for 6 months can be imposed. In majority of cases, HK Electric applies for Excavation Permit from Highways Department*.

* For minority of cases, HK Electric has to apply for permit from other Government authority.

- Fees to be paid by HK Electric for each Excavation Permit granted by Highways Department.

Application Fee	HK\$2,360 / permit
Daily Fee	HK\$40 / day
Extension Fee	HK\$750 / permit

- Unless with accepted reasons, a daily economic cost will be charged to HK Electric if HK Electric does not complete the excavations involving carriageway on time and extension is required.

Strategic Streets	HK\$23,600 / day
Sensitive Streets	HK\$9,120 / day
Streets other than the above two classes	HK\$1,850 / day

Time required for HK Electric to register and submit an application for an Excavation Permit before work commencement:

1. Minimum Registration Lead Time:

Works on carriageway of trunk roads or works on any carriageway exceeding 3 months	6 months
Works on carriageway other than trunk roads not exceeding 3 months or works not on carriageway but exceeding 3 months	2 months
Works not on carriageway and not exceeding 3 months	1 month

2. HK Electric is also required to coordinate with other utility undertakers for the program of work such that the overall disturbance brought to the public will be kept to a minimum before Highways Department granting the Excavation Permit. These utility undertakers include the telecommunication service companies, Gas Company, Drainage Service Department, Water Supplies Department, and etc. Also, Highways Department imposes a 3-month excavation restriction period after excavation by all other Utilities Undertakings to avoid repeated excavation in the same location. A 6-month restriction period will be imposed by Highways Department after excavation by HK Electric at the same location.

3. HK Electric has to obtain consent from Transport Department and Hong Kong Police Force of the proposed excavation work before Highways Department grants the Excavation Permit to HK Electric. With the current arrangement, Transport Department and Hong Kong Police Force will only provide comments to HK Electric excavation proposals for the excavation works in Traffic Management Liaison Group Meeting (TMLG Meeting) with limited meeting time each month.

4. HK Electric may be required to approach the following parties for their comments or consent of the excavation work before Highways Department grants the Excavation Permit to HK Electric:

- Environmental Protection Department
- Leisure and Culture Services Department
- Architectural Services Department
- MTR Corporation Limited
- E&M Services Department

5. Overall time required for obtaining an Excavation Permit from Highways Department:

More than 10 weeks (excluding the registration time) for a typical case in footpath.

For more information: You may visit the website of Highways Department <http://www.hyd.gov.hk> for more details on Excavation Permit.

Drg. No. GCS/3/26
INFORMATION ON APPLICATION FOR EXCAVATION PERMIT SHEET 2 OF 2

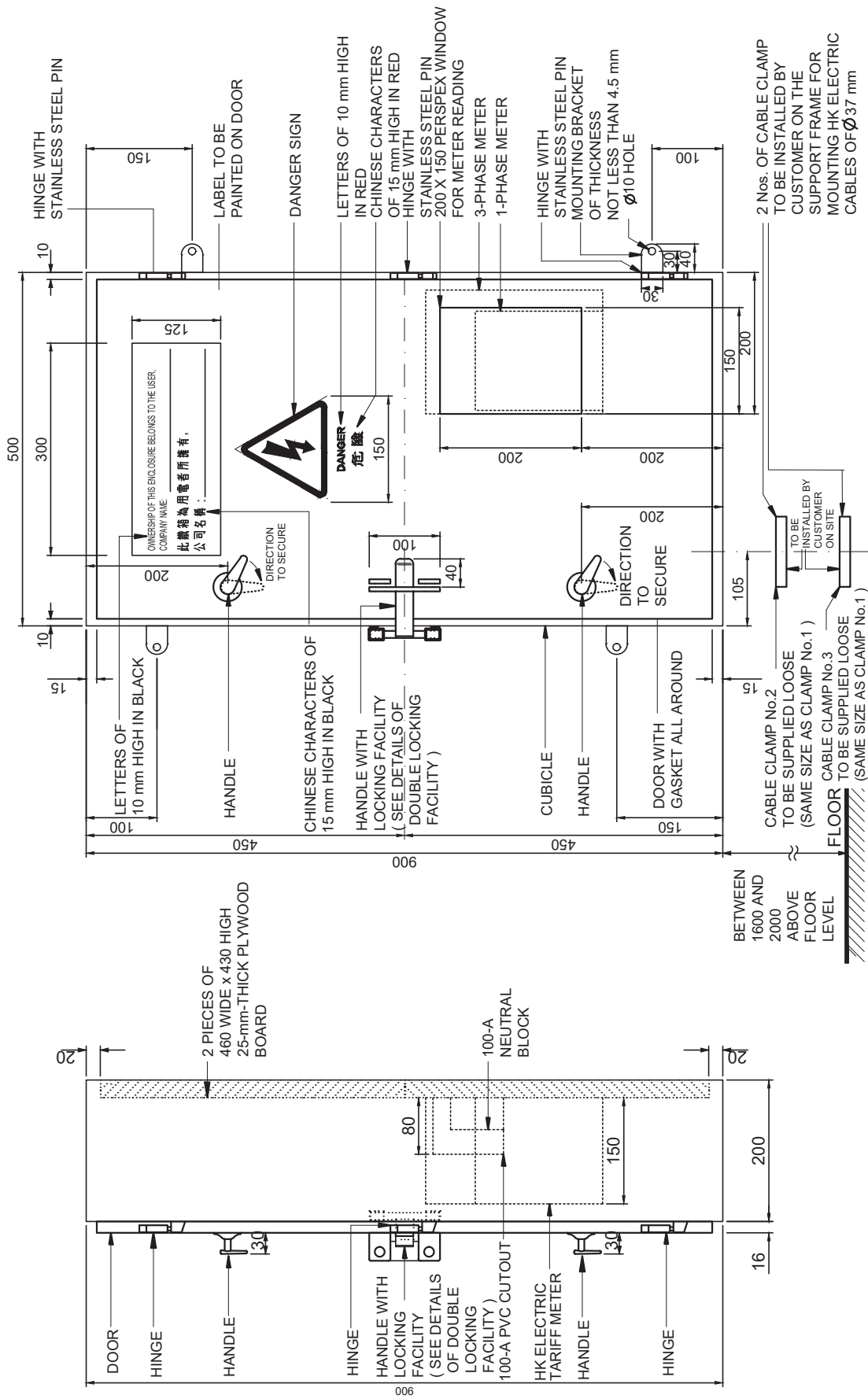

SIDE VIEW

FRONT VIEW

NOTE : ALL DIMENSIONS ARE IN mm.

Drg. No. GCS/3/27

MILD STEEL WEATHERPROOF ENCLOSURE FOR SITE SERVICES UP TO 100 A 3-PHASE
(P630/06/R-2) SHEET 1 OF 4

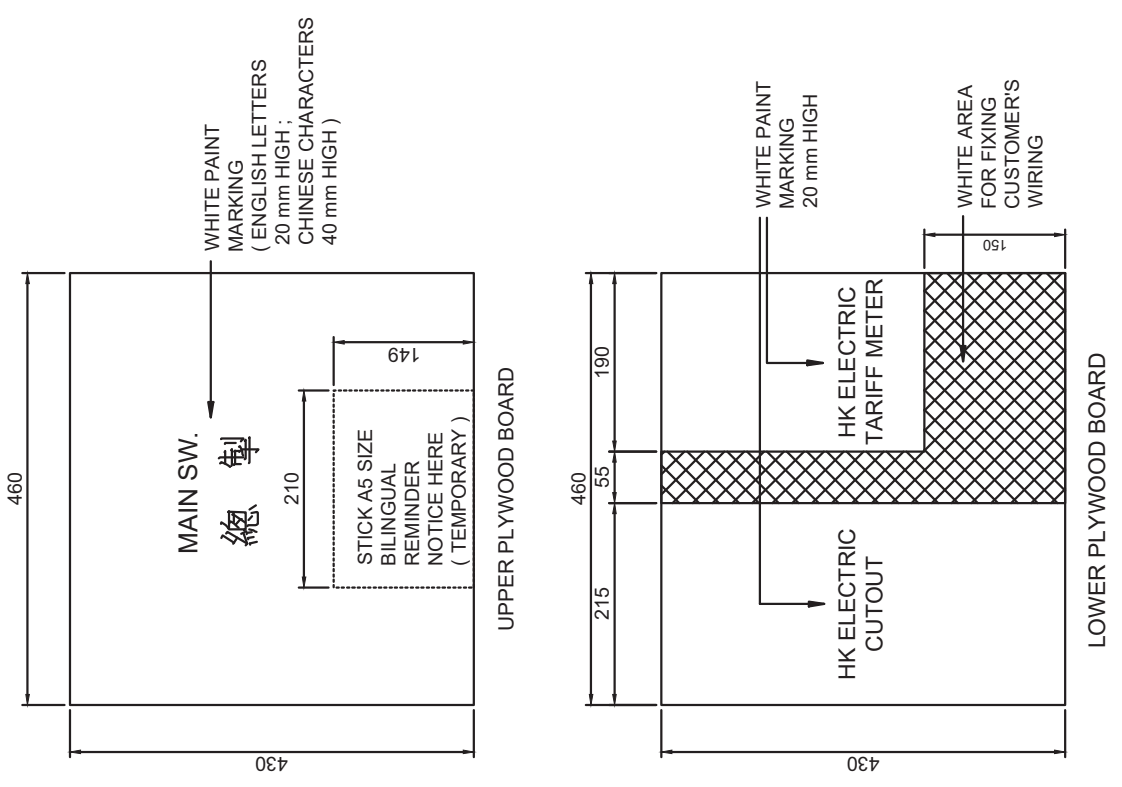

DETAILS OF PLYWOOD BOARD

NOTE : ALL DIMENSIONS ARE IN mm.

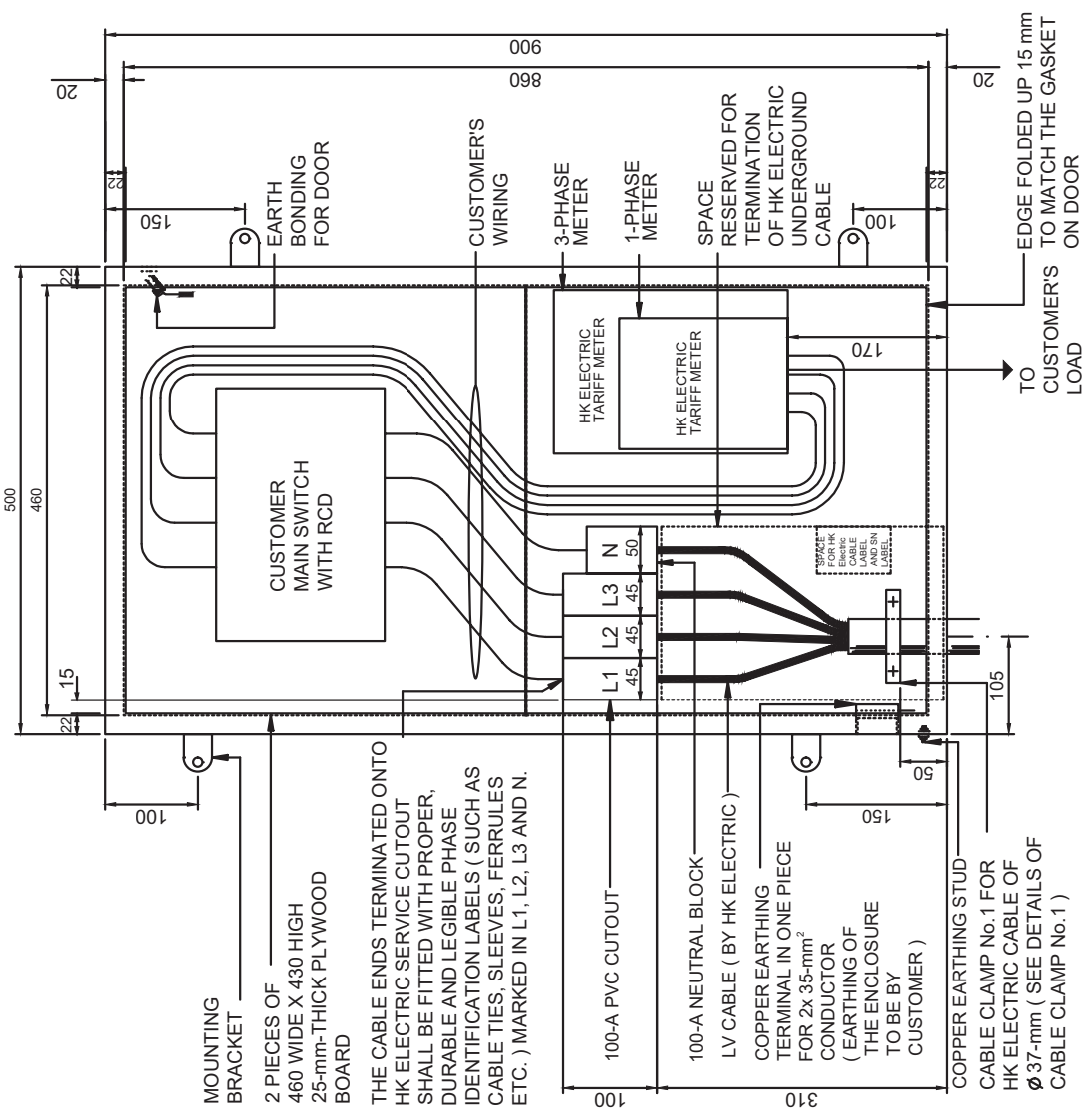

INNER FRONT VIEW

(ENCLOSURE DOOR OMITTED FOR CLARITY)

Drng. No. GCS/3/27

MILD STEEL WEATHERPROOF ENCLOSURE FOR SITE SERVICES UP TO 100 A 3-PHASE
(P630/06/R-2) SHEET 2 OF 4

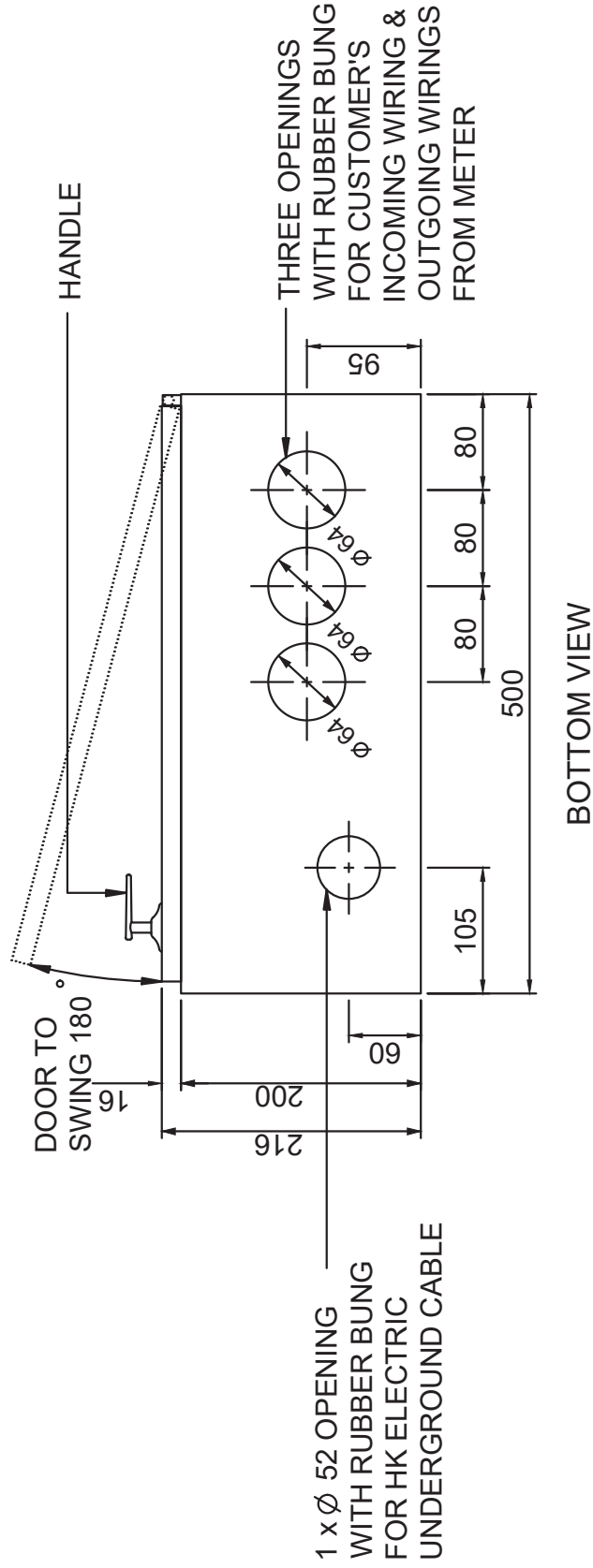
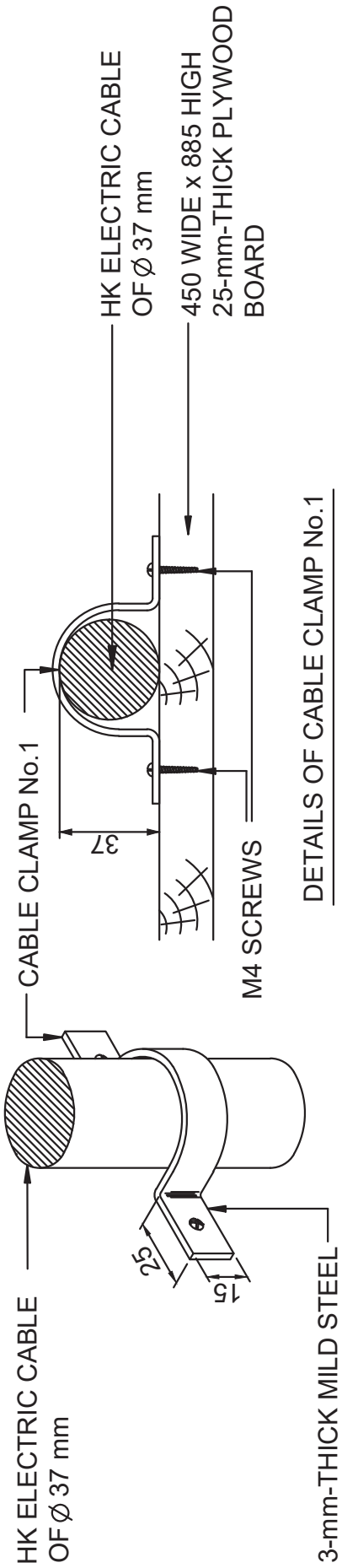

NOTE : ALL DIMENSIONS ARE IN mm.

Drg. No. GCS/3/27

MILD STEEL WEATHERPROOF ENCLOSURE FOR SITE SERVICES UP TO 100 A 3-PHASE

(P630/06/R-2) SHEET 3 OF 4

NOTES :

1. THE ENCLOSURE TOGETHER WITH HK ELECTRIC SERVICE CUTOFF, METER AND WIRING (EXCLUDING CUSTOMER MAIN SWITCH) IS OF APPROXIMATE WEIGHT OF 40 kg.
2. CUSTOMER SHALL PROVIDE ROBUST STEEL SUPPORT FRAME FOR MOUNTING THE ENCLOSURE TO ENSURE SAFETY EVEN DURING TYPHOON SEASON.
3. THE ENCLOSURE SHALL BE COLLECTED AND INSTALLED BY CUSTOMER AND WILL BE SUBSEQUENTLY LOCKED BY CUSTOMER AND BY HK ELECTRIC.
4. ALL DIMENSIONS ARE IN mm.

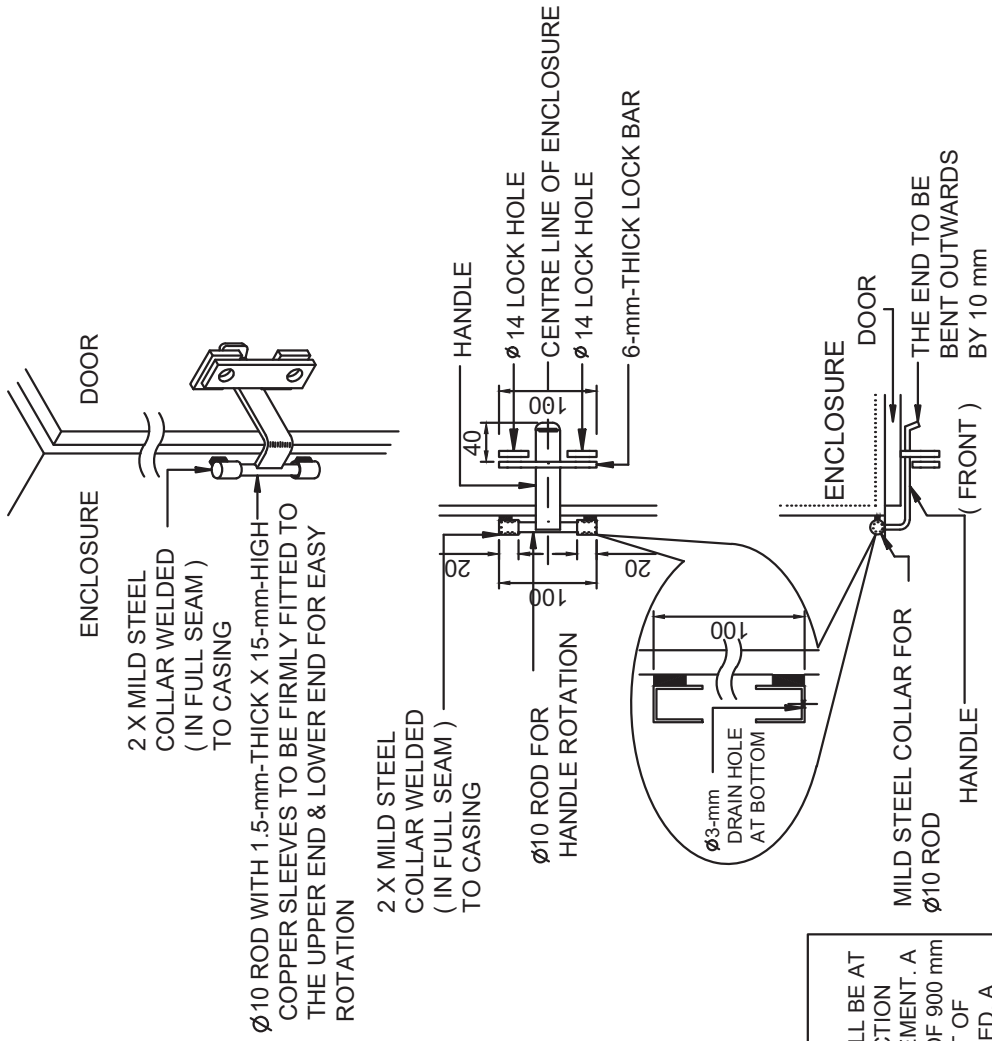

**DETAILS OF
DOUBLE LOCKING FACILITY**

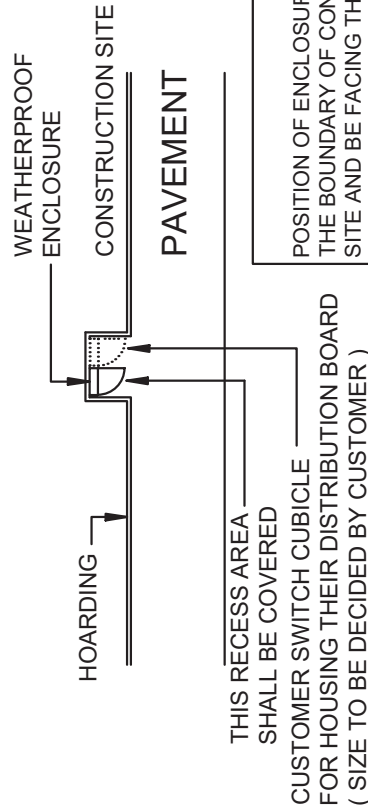

LOCATION PLAN

POSITION OF ENCLOSURE SHALL BE AT THE BOUNDARY OF CONSTRUCTION SITE AND BE FACING THE PAVEMENT. A MINIMUM CLEARANCE SPACE OF 900 mm FOR THE FULL WIDTH IN FRONT OF ENCLOSURE SHALL BE PROVIDED. A CLEAR ACCESS TO THE ENCLOSURE SHALL BE PROVIDED WITHOUT ANY OBSTRUCTION FROM COVERED WALKWAY.

Drg. No. GCS/3/27

**MILD STEEL WEATHERPROOF ENCLOSURE FOR SITE SERVICES UP TO 100 A 3-PHASE
(P630/06/R-2) SHEET 4 OF 4**

<p>1. In general the operation of a substitution door with decoration cladding or a decorative door in addition to the standard substitution door would occupy much larger area of pavement in front of the substitution. Any such decorative features on the substitution door or the addition of a decorative door should be avoided as far as practicable from operational point of view. In case any substitution door is of such design and/or an additional decorative door in front of the substitution door is proposed, HK Electric shall have the discretion on the acceptance of such proposal depending on the actual site situation. The architect/developer shall submit their proposal in the substitution design stage for HK Electric consideration. This drawing depicts only the general conditions on acceptance of an additional decorative door in front of the substitution door of a ground floor substitution and/or attaching external decorative cladding to substitution door for reference purpose.</p> <p>2. <u>General requirements for both the substitution door with decoration cladding and the additional decorative door in front of the standard substitution door of a substitution at ground floor</u></p> <p>2.1 A canopy above the substitution door shall be provided according to HK Electric drawing.</p> <p>2.2 A space of not less than 1,000 mm (H) x 600 mm (W) at 1,400 mm centre above pavement level, with proper mounting facilities shall be provided for mounting the substitution name plates and warning sign on external surface of the door.</p> <p>2.3 The proposed additional door or decorative louvres/cladding on the standard substitution door shall not result in any adverse effect on the substitution ventilation system and a minimum flow rate as stipulated in the substitution layout drawing shall be achieved when the substitution ventilation system is operating. A site measurement is required to confirm compliance after the decorative louvres/cladding or the additional decorative door is installed.</p> <p>2.4 In case there is any defect/malfunction of the substitution ventilation system which may affect the substitution temperature, the developer shall be responsible for keeping the additional door fully open (or dismantling the additional door if keeping the additional door open in a prolonged manner is not allowed due to the possible obstruction at site) / detaching the decorative louvres/cladding from the substitution door to facilitate the air circulation upon request by HK Electric.</p> <p>2.5 A confirmation letter shall be provided from the developer to undertake the responsibilities for future repair/maintenance of the additional substitution door and the proposed decorative louvres/cladding on both the substitution door and the external wall in case of damage by HK Electric during initial equipment delivery and future transportation of supply apparatus to and from the substitution. The letter shall also confirm their compliance with all the requirements stipulated in this Drawing. A copy of as-built drawing with photos specifying the decorative louvres/cladding on both the substitution door and the external wall being covered by the above undertaking letter shall be submitted for record after occupation permit of the development is granted.</p>	<p>2.6 <u>Substitution Door Swing</u></p> <p>The substitution door shall be able to fully open with 180 degree swing with a clear opening of not less than 2.0 m (W) x 2.6 m (H) after the substitution door and the additional decorative door have been fully opened for transportation of HK Electric equipment to and from the substitution. A 150 degree swing of the substitution door while maintaining a clear opening of not less than 2.0 m (W) x 2.6 m (H) will also be acceptable provided the following conditions are met:</p> <p>(i) The substitution door and the additional decorative door, when being opened outwards over any street, must not cause an obstruction to any person or vehicle using the street.</p> <p>(ii) The substitution door is facing a street with footpath of clear width of more than 2.5 m where manual transportation of HK Electric equipment to and from the substitution is allowed, or a 2m wide clearance in the footpath in front of the substitution door opening can be maintained when both the substitution door and the decorative door are fully opened. Otherwise an arrangement for transportation of HK Electric equipment to and from the substitution via the substitution door should be provided by the architect/developer for agreement/acceptance by HK Electric.</p> <p>(iii) Stoppers shall be designed and provided to prevent the decorative louvres/cladding from being damaged in the course of movement of the substitution door. Stopper(s) shall also be provided for the additional door by the same token.</p> <p>(iv) Latch or similar means shall be designed and provided to secure the decorative door and the standard substitution door at its fully open positions to avoid swinging back of the door(s) in case of strong wind condition.</p> <p>2.7 The decorative louvres/cladding on the substitution door and/or the additional decorative door shall not obstruct the operations of the lockbar of the standard substitution door and shall not endanger the operator when opening and carrying out the locking/unlocking operation of the substitution door/ additional door.</p> <p>3. <u>Other requirements for additional door in front of a standard substitution door of a ground floor substitution</u></p> <p>3.1 The additional decorative door fitting shall be of suitable size which could allow smooth operation and shall comply fully with the following requirements:</p> <p>(i) At least 4 Nos. of hinges shall be provided at each door leaf. The hinges shall be so designed such that the Door will open in the direction of egress. Life lubricated hinges shall be provided.</p> <p>(ii) For double door, the right hand side leaf shall be opened first when viewed from outside.</p> <p>(iii) Pull handles of stainless steel shall be provided for single door and for both leaves or double door.</p>	<p>(iv) Equipotential bonding shall be provided for the additional door according to the latest edition of Code of Practice for the Electricity (Wiring) Regulations published by Hong Kong SAR Government.</p> <p>3.2 The decorative door and its frame shall not obstruct future maintenance/replacement of the standard substitution door.</p> <p>3.3 The development owner/management company is not allowed to apply lock of any form on the additional door. In case locking of such additional door is necessary, a stainless steel lock bar shall be provided and be suitable for HK Electric pad lock with shackle diameter of 14 mm, a clear inside width of 20 mm and inside length of 16 mm. The position of lock bar shall be at 1100 mm to 1500 mm above finished floor level. For Double Door, the lock bar shall be on the left hand side leaf when viewed from outside. Vertical bolts shall be provided for the left hand side leaf to secure in position before closing the right hand side leaf.</p> <p>3.4 In addition to the requirement of providing proper facilities for mounting HK Electric door label/warning sign as described in above item 2.2, the development owner is also required to post a durable sign/label on the additional decorative door to explicitly state their ownership and responsibilities of maintenance/repair of the additional door for easy site identification.</p> <p>4. <u>Other additional requirements for attaching external decorative louvres/cladding to a standard substitution door</u></p> <p>4.1 The hinges of the door shall be designed and constructed to withstand the operating weight of the door with the proposed decorative louvres/cladding plus 50 kg (assuming at centre of door leaf) in order to cater for the weight of accessories which HK Electric may install onto the door and minimum four Nos. of door hinges shall be provided on each leaf of the doors. For door exceeding the standard height and width, extra hinges shall be provided.</p> <p>4.2 For 1/F substitution or substitution with same arrangement of equipment transportation as specified by HK Electric, decorative louvres/cladding shall be attached to the substitution door as far as practicable and the decorative louvres/cladding on top of the substitution door, if any, shall be detachable to avoid any damage during the operation of equipment transportation. For exceptional case approved by HK Electric that the decorative louvres/cladding are mounted on the external wall of building, the developer is responsible for arranging facilities and manpower for closing/opening of the decorative louvres/cladding for HK Electric equipment transportation work, inspection and maintenance work, etc. as and when required by HK Electric. In addition, the developer is responsible for closing and making good, if damage, of the decorative louvres/cladding after completion of equipment transportation in case HK Electric is required to arrange opening of the decorative louvres/cladding on behalf of the developer for emergency purpose.</p>
--	---	--

Dr. No. GCS/3/28

CONDITIONS ON ACCEPTANCE OF ATTACHING EXTERNAL DECORATIVE LOUVRES/CLADDING TO SUBSTATION DOOR OR ADDITIONAL DECORATIVE DOOR IN FRONT OF SUBSTATION DOOR OF GROUND FLOOR SUBSTATION (P753/14/R-1)

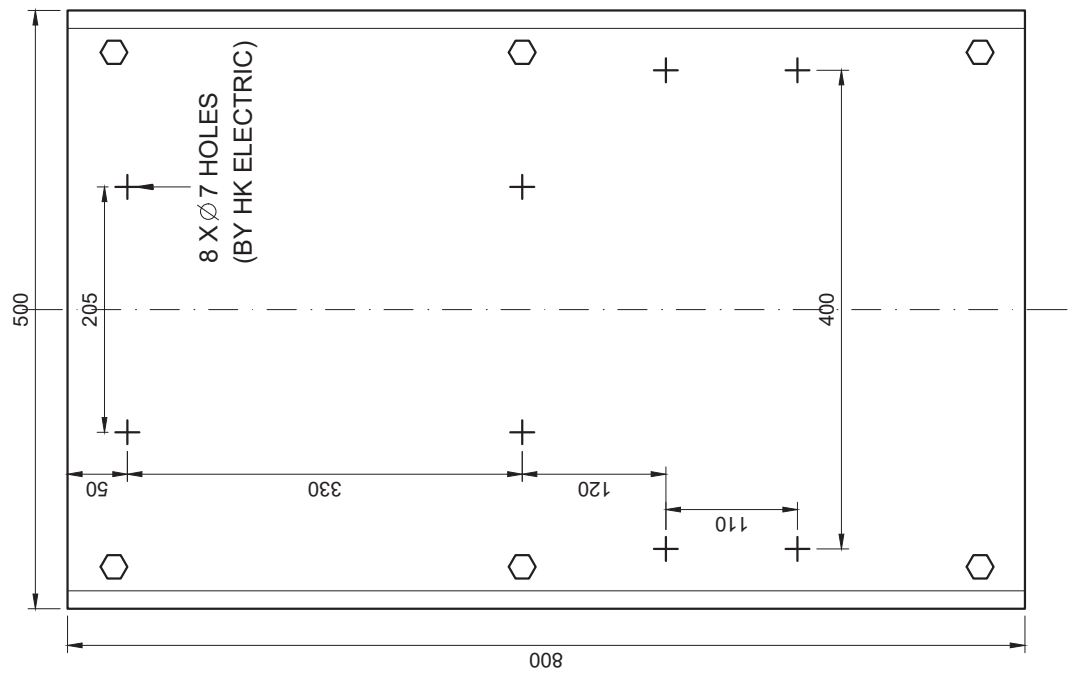
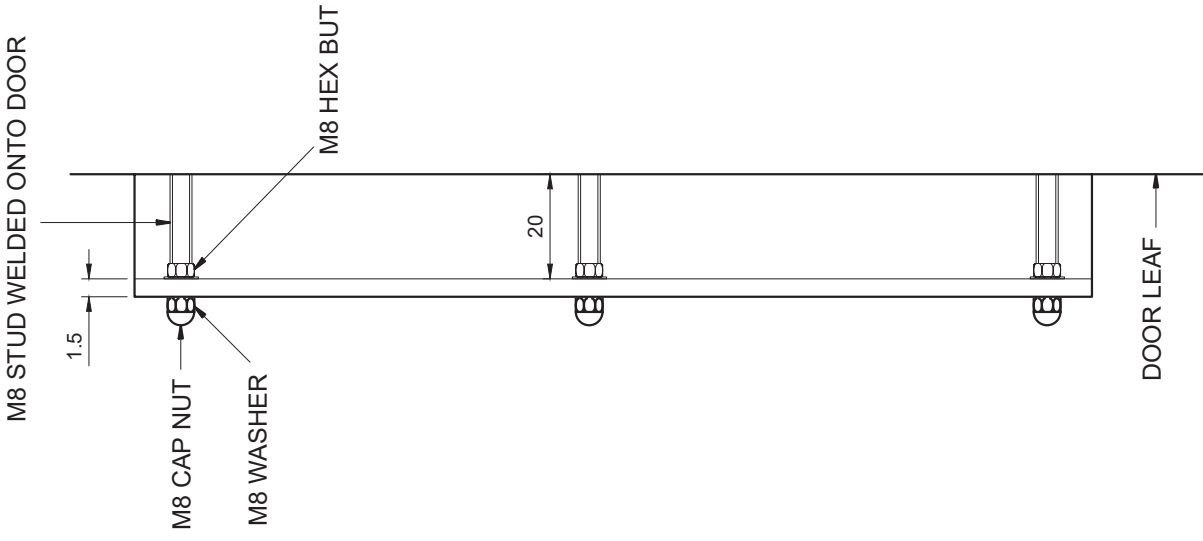

NOTE : ALL DIMENSIONS ARE IN mm.

FIGURE (a) : DETAILS OF FIXING ARRANGEMENT FOR LABEL MOUNTING PLATE

(N.T.S.)

Drg. No. GCS/3/29

REQUIREMENTS ON FIRE RESISTING DOOR FOR SUBSTATIONS (P339/97/R-7)

Notes for Drawing No. GCS/3/29

1. Stainless steel referred in this Specification shall mean stainless steel of Grade 316.
2. The Fire Resisting Door (the Door) shall be installed in HK Electric substation only if it is definitely required FSD of HKSAR Government.
3. The Door shall be type tested to the latest edition of BS 476 for:
 - a. A Fire Resistance Period required by FSD; or
 - b. A Fire Resistance Period of 2 hours,whichever the Fire Resistance Period is longer.
4. Before substation hand-over, the following documents shall be submitted to the HK Electric Engineer:
 - a. A copy of certificate from the manufacturer stating that the Door has complied with the above tests and all the FSD's requirements.
 - b. A confirmation letter from the developer undertaking the responsibilities for future maintenance of the Door.
5. The Door shall be single swing. The Door shall be of double leaf or single leaf as specified by HK Electric. For Double Leaf Door, the right hand side leaf shall be opened first when viewed from outside.
6. Unless otherwise specified by HK Electric in the substation layout drawing, clear opening of the Door shall be of:
 - a. Height not less than 2600 mm and width not less than 2000 mm for Double Door.
 - b. Height not less than 2300 mm and width not less than 920 mm for Single Door.
7. The facing of the Door shall be of stainless steel sheet of thickness not less than 1.5 mm.

Notes for Drawing No. GCS/3/29

8. Should there be a built-in cylinder lock in the original design of the Door, it shall be rendered inoperative. A stainless steel lock bar shall be provided and be suitable for HK Electric pad lock with shackle diameter of 14 mm, a clear inside width of 20 mm and inside length of 16 mm. The position of lock bar shall be at 1100 mm to 1500 mm above finished floor level. For Double Door, the lock bar shall be on the right hand side leaf when viewed from outside. Vertical bolts shall be provided for the left hand side leaf to secure in position before closing the right hand side leaf.
9. Automatic door closer, if required by FSD or according to FSD's Regulations, shall be provided for the Door. Should self-closing device be installed on the Door, a substation door security rod as detailed in drawing No. P360/97/R-5 shall be provided.
10. Pull handles of stainless steel shall be provided for Single Door and for both leaves of Double Door.
11. At least 4 Nos. of hinges each not less than 80 mm long shall be provided at each door leaf. The hinges shall be so designed such that the Door will open in the direction of egress. Life lubricated hinges shall be provided. The hinges for each leaf of Door must be designed and constructed to withstand the operating weight of the Door plus 50 kgf (assuming at the centre of door leaf) in order to cater for the weight of accessories which HK Electric may install onto the Door.
12. Door stops shall be provided for the closing and the full opening of door leaves.
13. For mounting of HK Electric labels on the Door, a label mounting plate shall be provided on the external surface of the Door for fixing various labels. The label mounting plate shall be:
 - a. of stainless steel sheet not less than 1.5 mm thick with folding edges at the long side.
 - b. of dimensions 800 mm high and 500 mm wide at the centre of door leaf at right hand side. Bottom of mounting plate shall be at 1400 mm above ground.

Notes for Drawing No. GCS/3/29

- c. fixed by means of 6 Nos. of studs welded onto the facing of the Door. The fixing washers and nuts shall be provided. The mounting plate shall be 20 mm away from the door surface. All the studs, fixing washers and nuts shall be of stainless steel.

Details of fixing arrangement for label mounting plate are shown in Figure (a). The label mounting plate shall not obstruct the operation of the door lock bar.

- 14. Equipotential bonding shall be provided for the Door according to the latest edition of Code of Practice for the Electricity (Wiring) Regulations published by Hong Kong SAR Government.
- 15. The Door shall be covered with thick plastic sheets at the time the substation is handed over and such plastic sheets shall not be removed until the building construction work is completed, in order to avoid staining of the Door caused by splashing of corrosive liquids used on site.

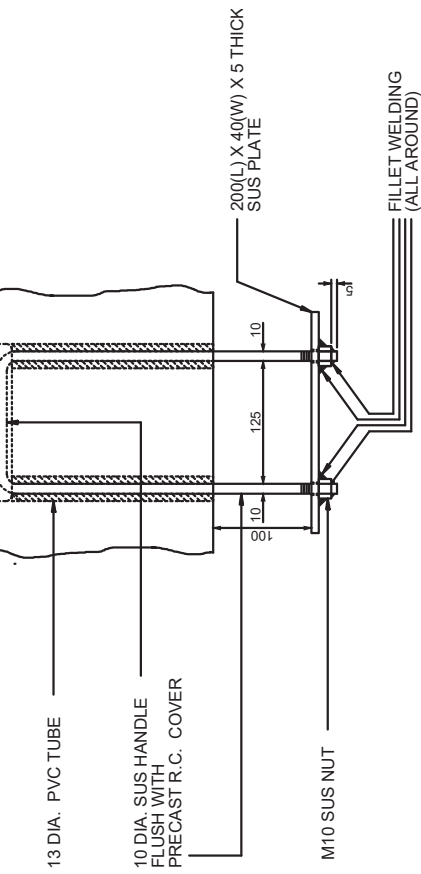

HANDLE FOR PRECAST R.C. COVER

HANDLE FOR PRECAST R.C. COVER

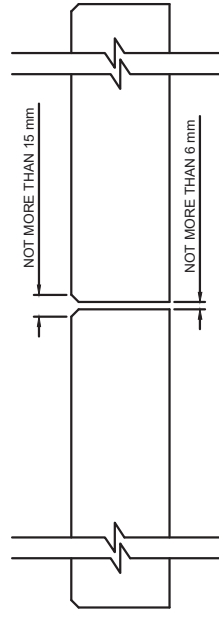

DETAIL 'G'

NOTE :

ALL DIMENSIONS ARE IN mm.

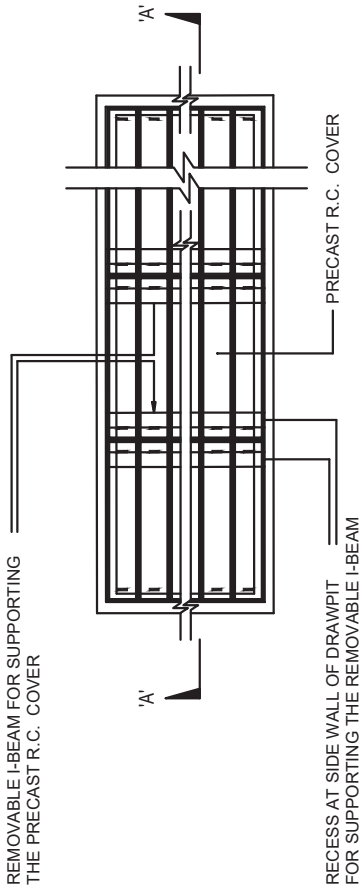

TYPICAL PRECAST R.C. COVER ARRANGEMENT OF CABLE DRAWPIT OR PREFORMED TRENCH

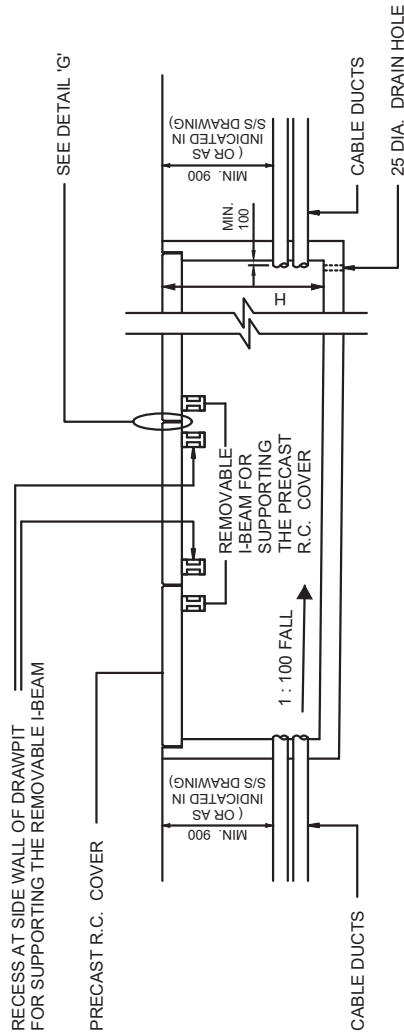

SECTION 'A - 'A'
TYPICAL DETAIL OF PRECAST R.C. COVER
/ I-BEAM FOR DRAWPIT OR PREFORMED TRENCH

Dr. No. GCS/3/30

REQUIREMENTS OF PRECAST REINFORCED CONCRETE COVER (P722/12/R-1)

Notes for Drawing No. GCS/3/30

1. Each piece of R.C. cover shall be provided with lifting eyes and shall not weigh above 80 kgf.
2. The precast R.C. covers shall be numbered in a sequential order by painting numbers of 50 mm high in white colour on both surfaces of each precast R.C. cover. Drawing showing the layout & numbering shall be displayed in substation.
3. Where the R.C. covers are along the route of transportation of substation equipment, the R.C. covers shall be capable of withstanding an average loading of 20 kPa. Otherwise the R.C. covers shall withstand 10 kPa.
4. Certificate by a registered structural engineer shall be submitted.
5. If H exceeds 1200 mm, SUS CAT ladder in steps of 250 mm shall be provided at a height 800 mm from bottom of drawpit or trench.
6. After HK Electric cables have been laid, the drawpit or trench shall be backfilled with sandbags each not exceeding 25 kgf.

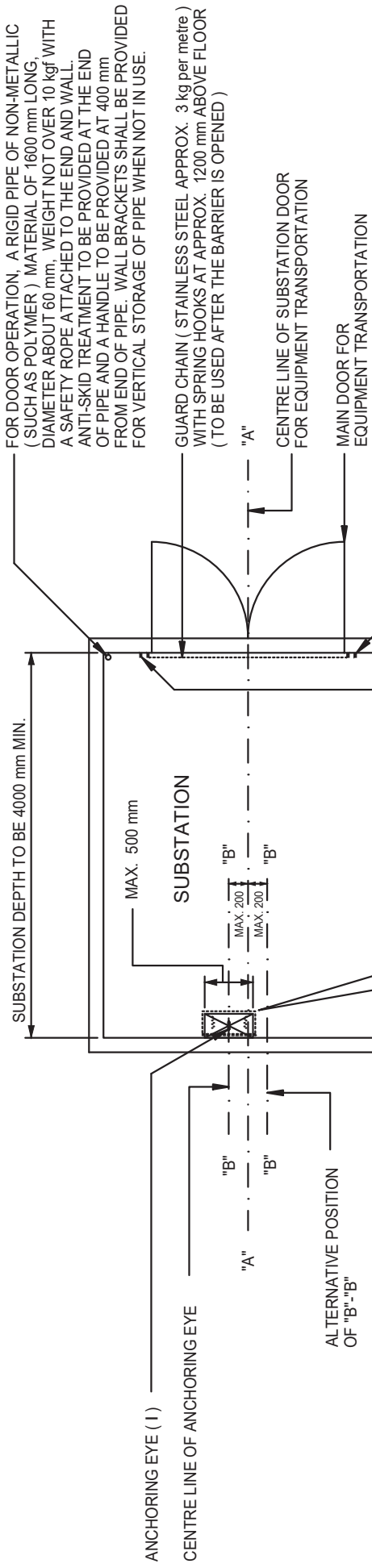

FOR DOOR OPERATION, A RIGID PIPE OF NON-METALLIC (SUCH AS POLYMER) MATERIAL OF 1600 mm LONG, DIAMETER ABOUT 60 mm, WEIGHT NOT OVER 10 kgf WITH A SAFETY ROPE ATTACHED TO THE END AND WALL ANTI-SKID TREATMENT TO BE PROVIDED AT THE END OF PIPE AND A HANDLE TO BE PROVIDED AT 400 mm FROM END OF PIPE. WALL BRACKETS SHALL BE PROVIDED FOR VERTICAL STORAGE OF PIPE WHEN NOT IN USE.

GUARD CHAIN (STAINLESS STEEL APPROX. 3 kg per metre) WITH SPRING HOOKS AT APPROX. 1200 mm ABOVE FLOOR (TO BE USED AFTER THE BARRIER IS OPENED)

"A"

CENTRE LINE OF SUBSTATION DOOR FOR EQUIPMENT TRANSPORTATION

MAIN DOOR FOR EQUIPMENT TRANSPORTATION

TOTAL 4 Nos. ANCHORING EYE (J) (150 kgf) FOR SAFETY BELT USE AT 1500 mm ABOVE FLOOR. WARNING LABEL STATING

" ANCHOR EYE BOLT FOR SAFETY BELT
救生繩牢固點

SHOULD BE AFFIXED BESIDE THE ANCHORING EYE (J). THE LABEL SHOULD BE RED IN WHITE BACKGROUND. SIZE OF SIGNAGE SHOULD BE 50 mm X 80 mm.

NOTE :

ALL DIMENSIONS ARE IN mm.

Drg. No. GCS/3/31

ANCHORING EYE AND FACILITIES FOR FIRST LEVEL SUBSTATION
 (P342/97/R-3) SHEET 1 OF 2

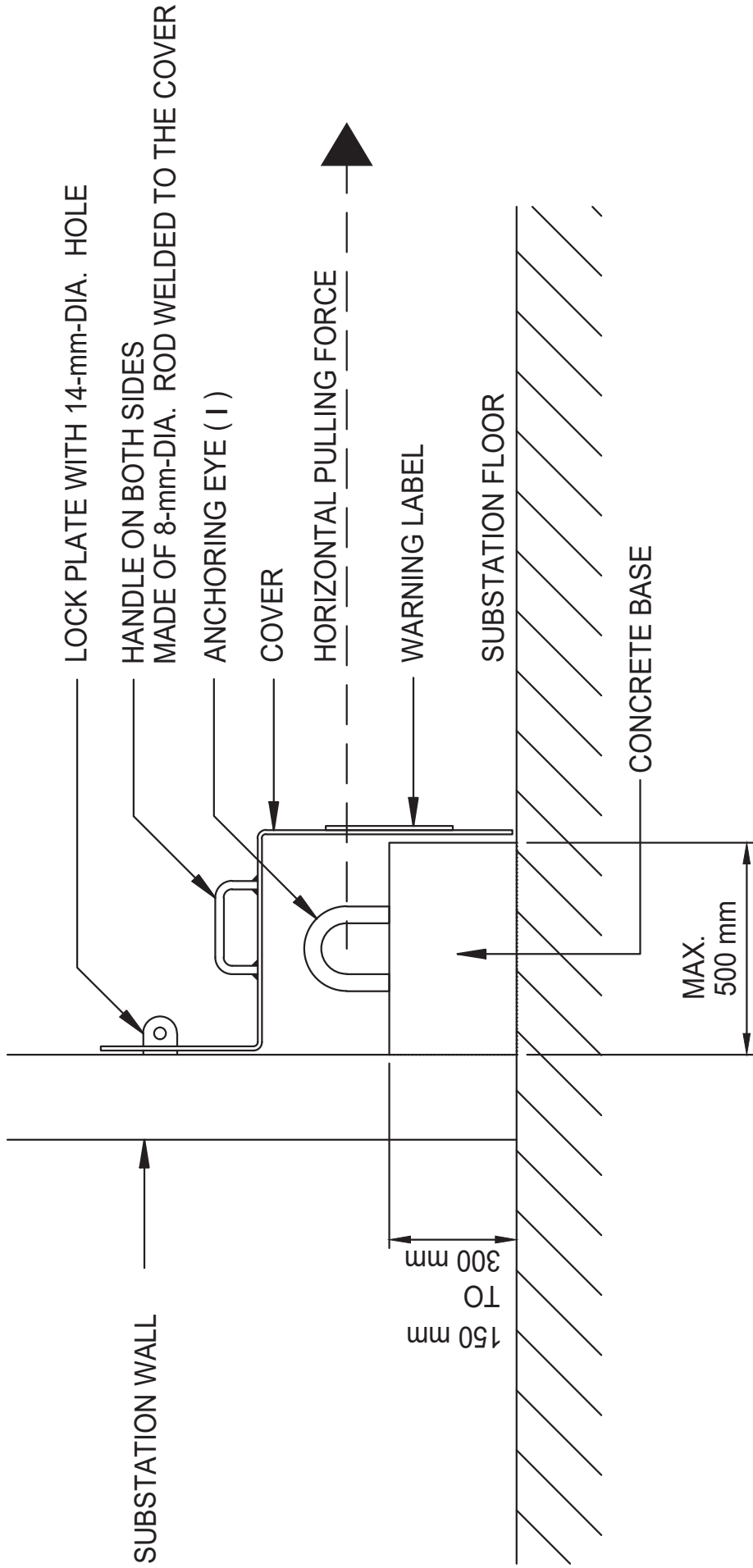

3.104

DETAILS OF ANCHORING EYE (I)

NOTE :

ALL DIMENSIONS ARE IN mm.

Drg. No. GCS/3/31
ANCHORING EYE AND FACILITIES FOR FIRST LEVEL SUBSTATION
(P342/97/R-3) SHEET 2 OF 2

Notes for Drawing No. GCS/3/31

1. The anchoring eye (I) will be used for transportation of equipment to and from the substation. A horizontal pulling force in direction along the centre line “A” – “A” will be applied to the anchoring eye (I). The anchoring eye (I) shall be suitable for a “SAFE WORKING LOAD” of 1000 kgf for such application, however the “TESTING LOAD” shall be 2000 kgf.
2. A certificate from a registered professional engineer in accordance with the factories and industrial undertakings ordinance shall be submitted to HK Electric certifying the above “TESTING LOAD” of anchoring eye (I) and the 150-kgf working load of anchoring eye (J).
3. All anchoring eyes shall be made of stainless steel, hot dip galvanised steel or steel with suitable anti-corrosion treatment. A concrete base shall be provided for the anchoring eye (I) to minimize corrosion to the eye due to lodgement of water on floor.
4. A cover with handle (covering the front, the top and the 2 sides) made of stainless steel or hot dip galvanised steel shall be provided to prevent the improper use of the anchoring eye (I). An engraved warning label stating:

“S.W.L. 1000 kgf DO NOT USE THE ANCHORING EYE BEFORE PROPER
TEST 未經測試不可使用”

shall be bolted on the front of cover. The lettering shall be approximately 15 mm high. A locking plate shall be provided on wall to lock the cover in position. The locking plate shall be suitable for padlocks with an 8 mm diameter shackle and a clear inside width of 20 mm and inside length of 16 mm.

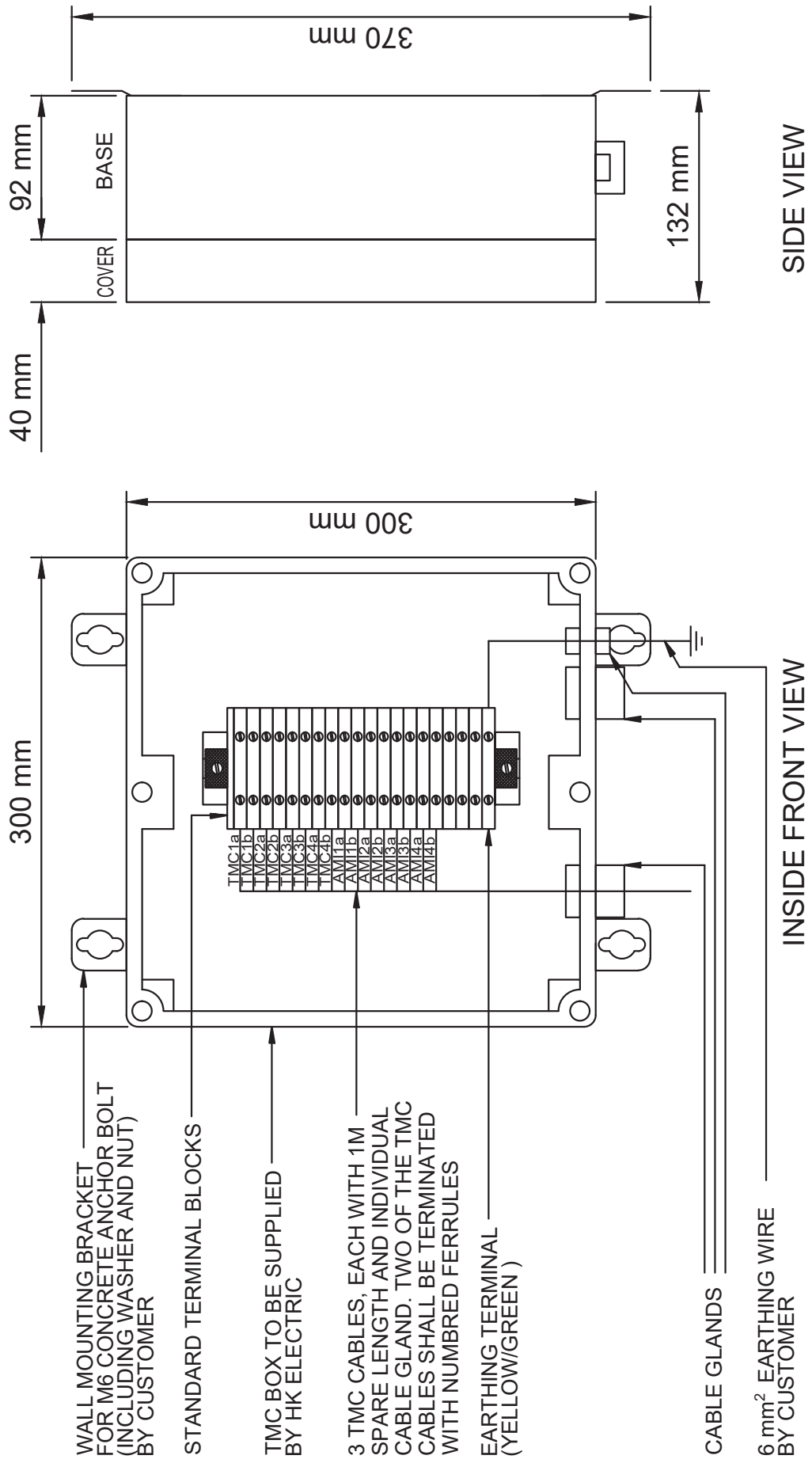

Drg. No. GCS/3/32

ARRANGEMENT FOR TARIFF METER COMMUNICATION (TMC) TERMINATION BOX

(P383/98/R-6) SHEET 1 OF 2

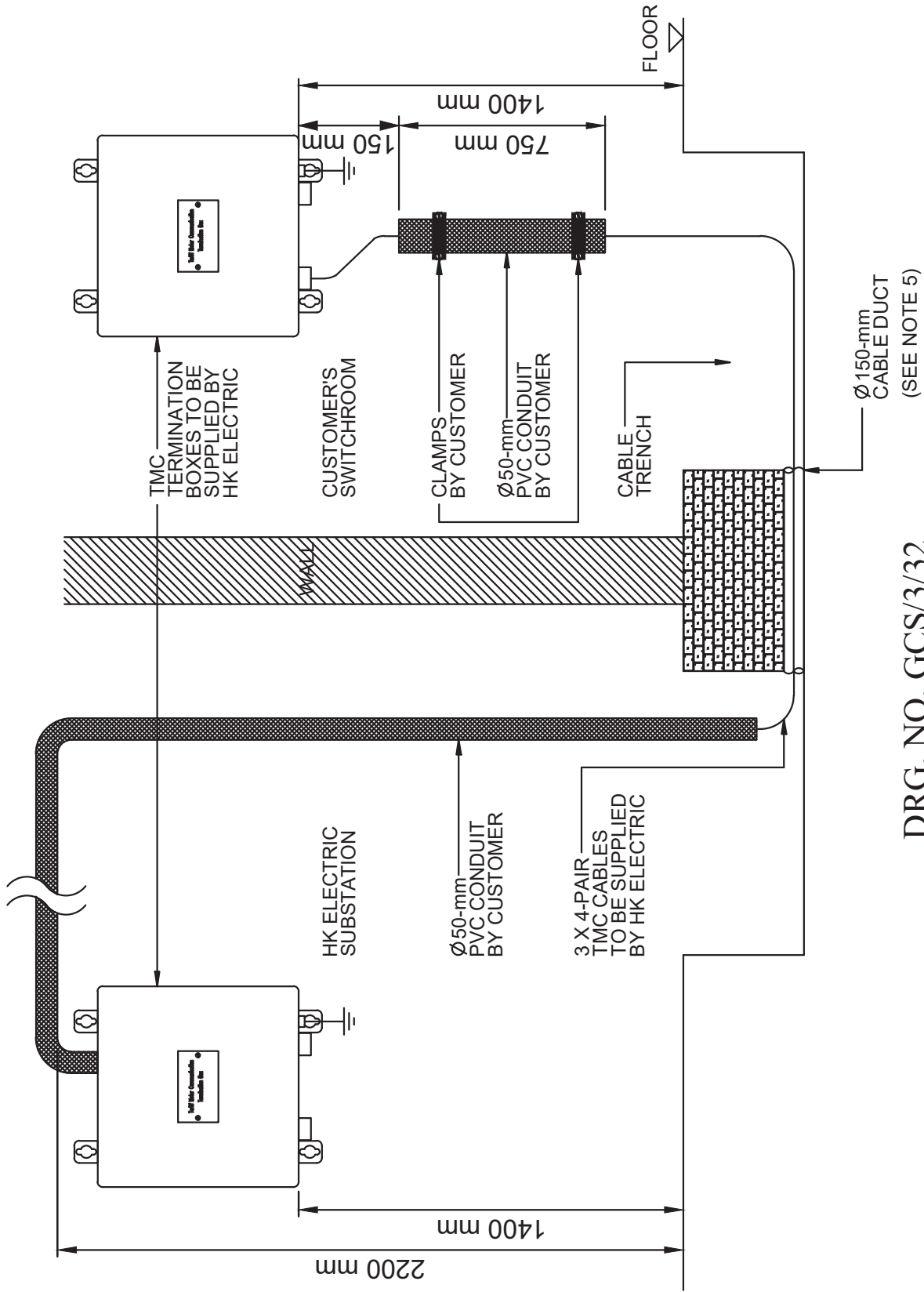

DRG. NO. GCS/3/32

ARRANGEMENT FOR TARIFF METER COMMUNICATION (TMC) TERMINATION BOX
(P383/98/R-6) SHEET 2 OF 2

Notes for Drawing No. GCS/3/32

1. 2 Nos. of termination boxes and 3 piece of 4-pair 8-core (1.5 sq. mm stranded conductor) cable to be supplied by HK Electric for Tariff Meter Communication (TMC) purpose shall be collected by customer and installed at site by customer.

One of the termination boxes shall be at customer's main switchroom and the other termination box shall be at HK Electric substation. Exact position is indicated on the substation layout plan.

The boxes shall be linked up with the 8-core TMC cables provided by HK Electric. Customer shall complete the cabling including fixing of cable glands and wire terminations before handing over the substation to HK Electric.

2. Each termination box is fully fitted with rail-mounted terminal block comprising 20 Nos. terminals. Two of the TMC cables shall be terminated with numbered ferrules as specific below:

1 st TMC Cable	TMC1a & TMC1b for pair 1 white & black cores TMC2a & TMC2b for pair 2 white & black cores TMC3a & TMC3b for pair 3 white & black cores TMC4a & TMC4b for pair 4 white & black cores
2 nd TMC Cable	AMI1a & AMI1b for pair 1 white & black cores AMI2a & AMI2b for pair 2 white & black cores AMI3a & AMI3b for pair 3 white & black cores AMI4a & AMI4b for pair 4 white & black cores
3 rd TMC Cable	Termination and numbered ferrule are not required

The two TMC cables shall be terminated on the left hand side & right hand side of terminals for the termination boxes in customer's main switchroom and HK Electric substation respectively. Terminal connection is by means of bare conductor and lugs are not required.

The TMC cable shall be enclosed in surface mounted 50-mm PVC conduits at customer's main switchroom and HK Electric substation.

Requirements for installation of 50-mm PVC conduit at HK Electric substation are:

- Conduit bends should have an internal radius of at least 4 times the outside diameter of the conduit.
- Conduit shall be supported and fixed to side wall at an interval of not more than 1200 mm. The method of anchoring conduit must be by red-head or similar device.

Notes for Drawing No. GCS/3/32

- Adaptable boxes should be provided immediately after every two bends, or after a bend plus a total maximum straight run of 10 metres or after a maximum straight run of 15 metres.
 - The method of carrying out the conduit bends, fixing conduits to boxes, and the tools and materials to be used should be as recommended by the manufacturer of the conduit.
3. Each termination box is fitted with a yellow/green earthing terminal at the end of the terminal block. A 6-sq. mm earthing wire shall be provided and terminated by the customer to the corresponding substation/switch room electrical conduit system.
 4. Each box shall be mounted on wall of substation/switch room at 1400 mm above finished floor level.
 5. The 150-mm-diameter cable duct shall be properly sealed off with fire resistant material and water-proofed against ingress of water by customer after TMC cable installed.

- NOTE : 1. * CUSTOMER MAY SLIGHTLY ADJUST THE ENCLOSURE SIZE TO SUIT THE DIFFERENT TYPE OF CUSTOMER MAIN SWITCH.
 2. DOUBLE LOCK ARRANGEMENT SHOULD BE PROVIDED IF THE ENCLOSURE IS LOCKED-UP BY CUSTOMER.
 3. ALL DIMENSIONS ARE IN mm.

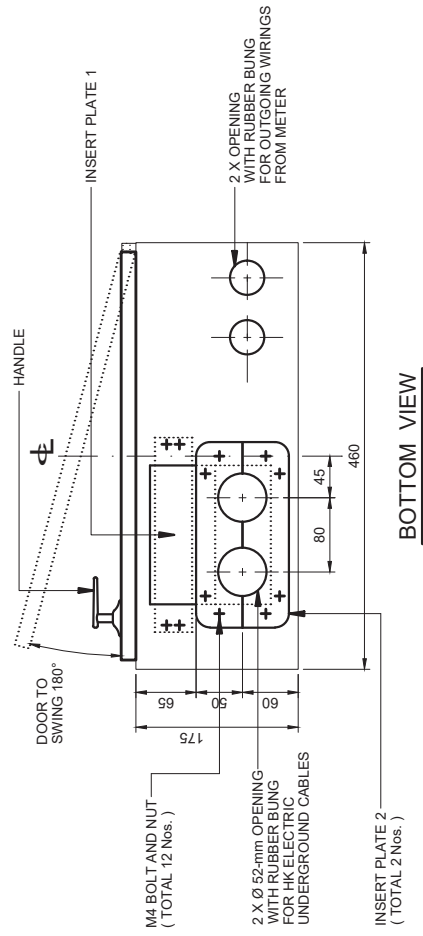

BOTTOM VIEW

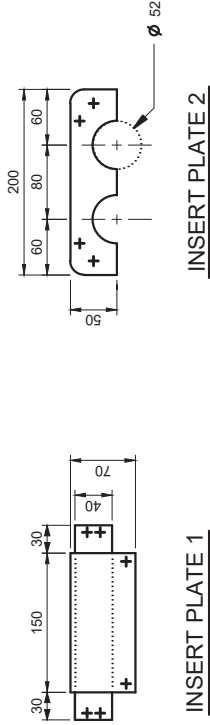

INSERT PLATE 1

INSERT PLATE 2

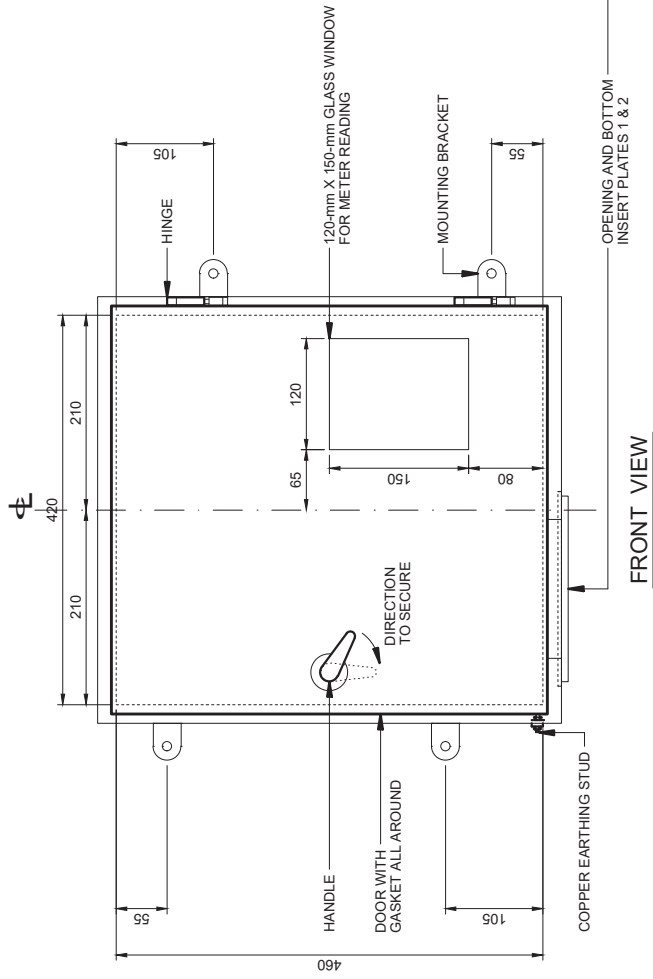

FRONT VIEW

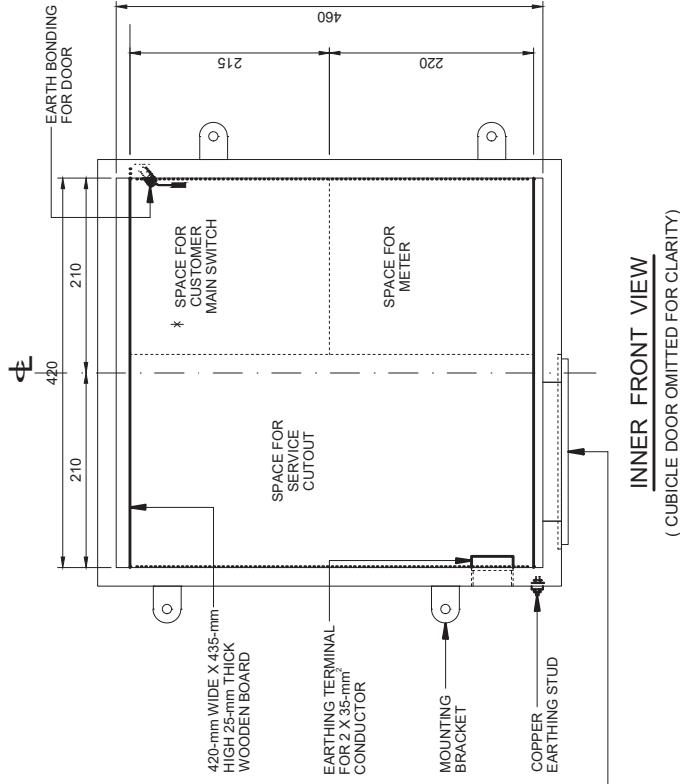

INNER FRONT VIEW

(CUBICLE DOOR OMITTED FOR CLARITY)

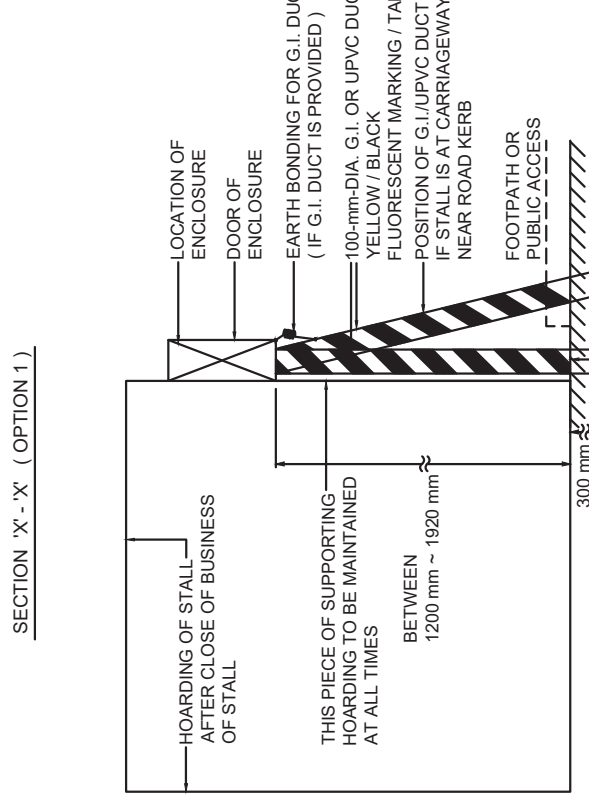
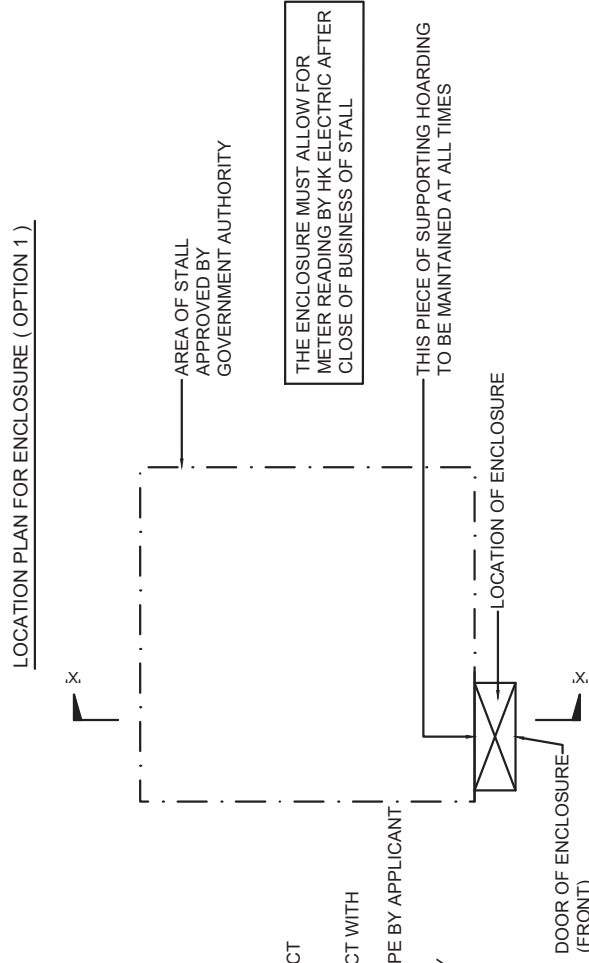
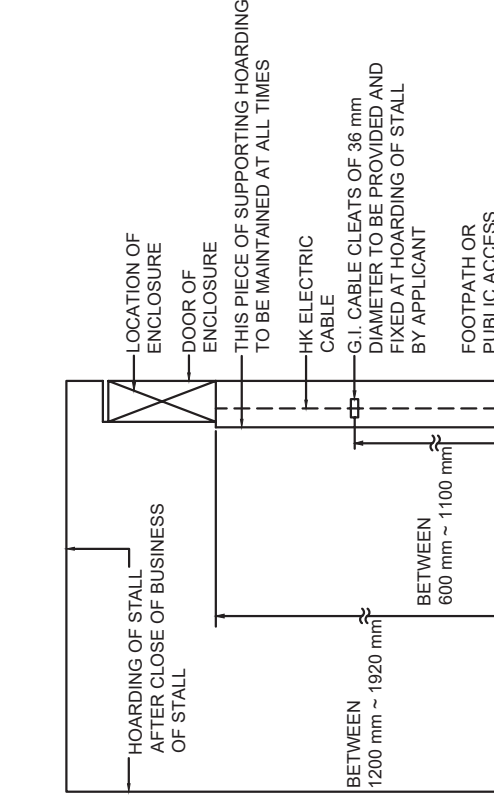
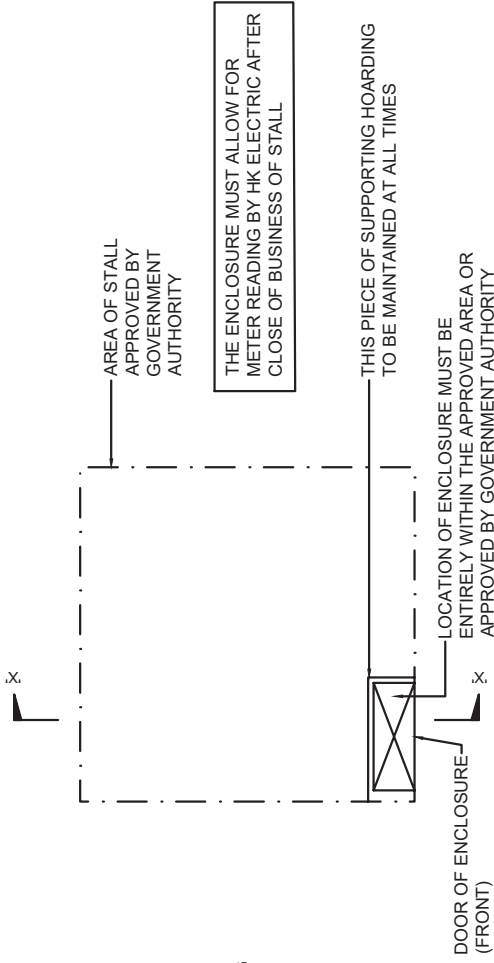

LOCATION PLAN FOR ENCLOSURE (OPTION 2)
 (CUSTOMER IS REQUIRED TO ENSURE THAT THE ENCLOSURE WILL NOT AFFECT PEDESTRIANS, SHOPS NEARBY AND OTHER CONCERNED PARTIES.)

NOTE : ALL DIMENSIONS ARE IN mm.

Drg. No. GCS/3/34

MILD STEEL WEATHER-PROOF ENCLOSURE FOR SINGLE PHASE SUPPLY TO HAWKER STALL (P717/12/R-3) SHEET 1 OF 2

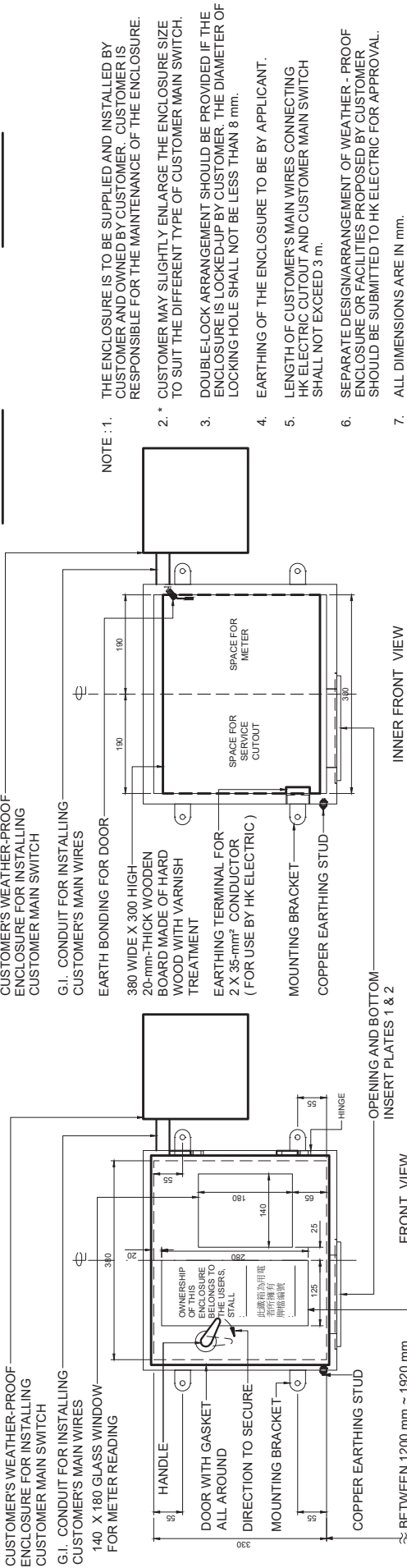
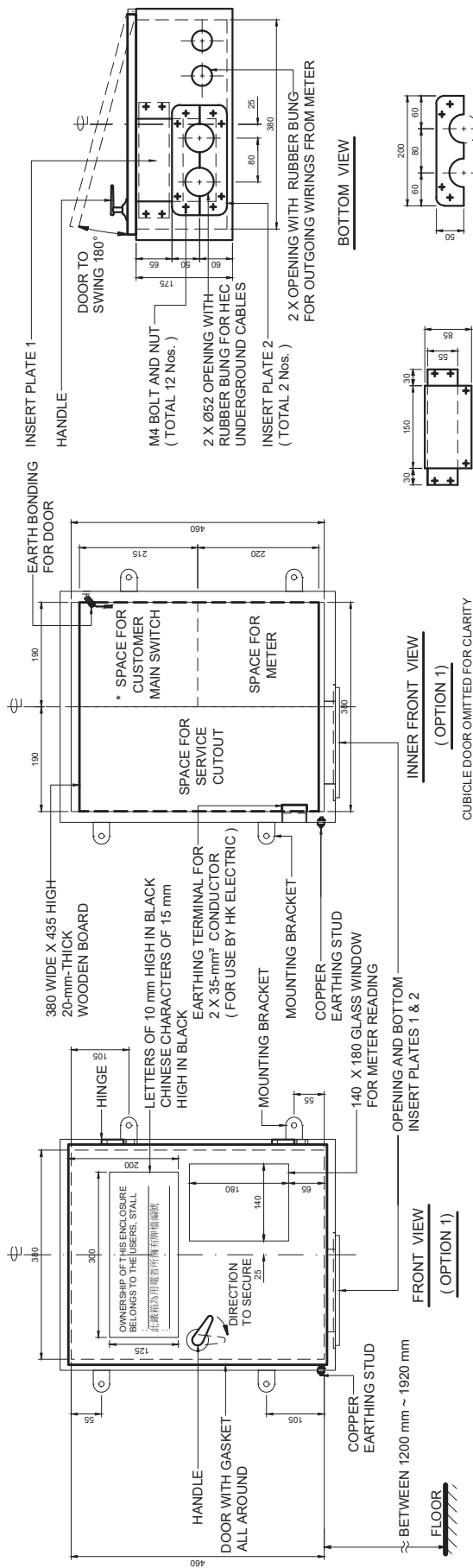

- NOTE : 1.
1. THE ENCLOSURE IS TO BE SUPPLIED AND INSTALLED BY CUSTOMER AND OWNED BY CUSTOMER. CUSTOMER IS RESPONSIBLE FOR THE MAINTENANCE OF THE ENCLOSURE.
 2. * CUSTOMER MAY SLIGHTLY ENLARGE THE ENCLOSURE SIZE TO SUIT THE DIFFERENT TYPE OF CUSTOMER MAIN SWITCH.
 3. DOUBLE-LOCK ARRANGEMENT SHOULD BE PROVIDED IF THE ENCLOSURE IS LOCKED-UP BY CUSTOMER. THE DIAMETER OF LOCKING HOLE SHALL NOT BE LESS THAN 8 mm.
 4. EARTHING OF THE ENCLOSURE TO BE BY APPLICANT.
 5. LENGTH OF CUSTOMER'S MAIN WIRES, CONNECTING HK ELECTRIC CUTOFF AND CUSTOMER MAIN SWITCH SHALL NOT EXCEED 3 m.
 6. SEPARATE DESIGN/ARRANGEMENT OF WEATHER - PROOF ENCLOSURE OR FACILITIES PROPOSED BY CUSTOMER SHOULD BE SUBMITTED TO HK ELECTRIC FOR APPROVAL.
 7. ALL DIMENSIONS ARE IN mm.

Drg. No. GCS/3/34

MILD STEEL WEATHER-PROOF ENCLOSURE FOR SINGLE PHASE SUPPLY TO HAWKER STALL (P717/12/R-3) SHEET 2 OF 2